



PARLIAMENT OF KENYA LIBRARY

THE NATIONAL ASSEMBLY	
DATE: 12 OCT 2022 Wednesday	
TABLED BY:	LOM
CLERK-AT THE-TABLE:	Miriam Modio Second Clerk Assistant

ANNUAL REPORT

2021/2022

www.iebc.or.ke | info@iebc.or.ke | facebook.com/IEBCKenya
Twitter: @IEBCKenya | Instagram: @iebcKenya

Your Vote, Your Future

Independent Electoral and Boundaries Commission (IEBC)

Vision

A credible electoral management body that meets the democratic aspirations of the people of Kenya.

Mission

To conduct transparent, efficient, and impartial elections; and to undertake boundary delimitation for equitable representation and sustainable democracy.

Core Values

The Commission subscribes to the following values:

- i. **Adherence to the rule of law:** We conduct our businesses within the law.
- ii. **Inclusivity:** We respect gender, race, class and disability in the conduct of electoral activities.
- iii. **Integrity:** We conduct our affairs with utmost honesty.
- iv. **Accountability** We endeavor to be responsible for our actions.
- v. **Teamwork:** We uphold teamwork to achieve Commission goals.
- vi. **Innovativeness:** We transform the electoral process to exceed the expectations of Kenyans.

The Independent Electoral and Boundaries Commission asserts right of recognition as author of the original material. The source should be attributed as Independent Electoral and Boundaries Commission Annual Report 2021/2022.

Produced by:	The Independent Electoral and Boundaries Commission
Website:	https://www.iebc.or.ke
Feedback and enquiries:	Feedback and enquiries on this report are welcome and should be directed to the contact officer.
Contact officer:	Commission Secretary/CEO, Anniversary Towers, 6 th Floor, University Way. P.O. Box 45371 – 00100, Nairobi, Kenya
Telephone:	+254 20 - 2877000
Email:	info@iebc.or.ke
Twitter:	@iebckkenya
Facebook:	Facebook.com/iebckkenya
Instagram	Instagram.com/iebckkenya

@ Copyright IEBC Kenya, 2022

TABLE OF CONTENTS

Letters of Transmittal.....	vi
List of Acronyms and Abbreviations.....	ix
SECTION 1: YEAR IN REVIEW.....	xiii
Foreword.....	Error! Bookmark not defined.
CHAIRMAN The Commission Secretary’s Overview.....	1
SECTION 2: ABOUT THE COMMISSION	5
2.1 The Commission	6
2.2 Our Mandate	7
2.3 The Legal Framework	7
2.4 Organization	10
2.5 The Commission.....	10
2.5.1 Members of the Commission	10
2.5.2 The Secretariat.....	12
2.6 The Commission Governance Structure	18
2.6.1 Plenary	18
2.6.2 Committees.....	18
2.7 The IEBC Strategic Plan 2020-2024.....	18
2.8 Structure of the IEBC Programmes.....	21
SECTION 3: PERFORMANCE INFORMATION BY PROGRAMME.....	22
3.1 Key Result Area#1: Strengthening Corporate Governance.....	23
3.2 Key Result Area#2: Strengthening the Legal Framework.....	25
3.3 Key Result Area#3: Effective Conduct of Elections	37
3.4 Key Result Areas#4: Public Outreach.....	41
3.5 Key Result Areas#5: Equitable Representation	45
3.6 Key Result Area #6: Strengthening Strategic Operations	49
3.6.1 Focus Area #1: Supply Chain Management.....	49
3.6.2 Focus Area #2 Financial Management	50
3.6.3 Focus Area #3 Electoral Systems and Infrastructure Sustainability.....	50
3.6.4 Focus Area #4: Human Resource Management and Administration.....	52
3.6.5 Focus Area 5 # Research and Development	56
3.6.6 Focus Area 6 # Electoral Risk Management	58
SECTION 4: FINANCIAL STATEMENTS	60
ANNEXES.....	161
Annex 1: Constitutional Petitions 2021/2022 Financial Year.....	154
Annex 2: Cases Investigated.....	168
Annex 3: Dispute resolution Committee.....	171
Annex 4: Contractual Agreements For Procurement Of Goods And Services	201
Annex 5: Memorandum Of Understanding (Mous) And Partnership Agreements With Partners.....	205
Annex 6: Gazette Notices Description	207
Annex 7: Map Requests	210
Annex 8: Election Data Request	212
Annex 9: List Of Training Manuals Reviewed	212
Annex 10: Accredited Voter Education Providers	213

List of Figures

Figure 1: Organization Structure.....	17
Figure 2: Focus Areas of the 2020-2024 IEBC Strategic Plan.....	19
Figure 3: IEBC Planning and Reporting Framework	20
Figure 4: Commission Committees	23
Figure 5: Current status of sub-locations boundary data collection by county	47
Figure 6: Distribution of staff within the Commission.....	55

List of Tables

Table 1: The Legislative Framework	7
Table 2: Structure of the IEBC Programmes.....	21
Table 3: Audits for Commission Activities	24
Table 4: International Liaisons and Collaborations.....	24
Table 5: Strengthening Legal Framework	26
Table 6: Commission's Legal Advisory Opinions	29
Table 7: Kenya Gazette Notices and Nature of Content.....	29
Table 8: Disputes Heard and Determined	31
Table 9: Investigation and compliance with Chapter six of the Constitution.....	31
Table 10: Leadership and Integrity Vetting Committee and Electoral Code of conduct cases.....	31
Table 11: Internal Investigation	32
Table 12: Summary of Chapter Six Working Group cases investigated	33
Table 13: Disqualified Aspirants to Contest in the 9th August 2022 General Election.....	33
Table 14: PPLC activities by Commission.....	34
Table 15: Challenges and Lessons learnt	36
Table 16: PPLC Political Parties Regulation.....	37
Table 17: Effective conduct of Elections	37
Table 18: Cascaded Training for Poll Officials	39
Table 19: By-elections conducted	40
Table 20: Review and development of manuals	41
Table 21: Effective conduct of elections.....	42
Table 22: The number of current sub-locations in the 38 counties completed	46
Table 23: Equity in Representation	48
Table 24: Supply Chain Management Activities	49
Table 25: Finance Management.....	50
Table 26: Electoral Systems and Infrastructure Sustainability.....	50
Table 27: Human Resource and Administration.....	52
Table 28: Commission Vacancies declared and Advertised in the period 2021/2022	54
Table 29: Staff Turnover.....	55
Table 30: Disaggregation of Staff by Gender.....	55
Table 31: Status report of County Warehouse Construction August 2022.....	56
Table 32: Research and Strategy	57
Table 33: Risk management.....	58
Table 34: Risk management Structure	59

Letters of Transmittal

INDEPENDENT ELECTORAL AND BOUNDARIES COMMISSION



30th September, 2022

H.E. Hon. Dr. William Samoei Ruto, C.G.H.,
President of the Republic of Kenya, &
Commander-in-Chief of the Defence Forces,
P.O. Box 62345-00200,
Harambee House,
NAIROBI.

I have the pleasure of presenting the Annual Report of the Independent Electoral and Boundaries Commission (IEBC) for the year ending 30th June 2022.

This report has been prepared for purposes of:

- i) Article 254 of the Constitution of Kenya, 2010 and Section 24(1) of the Independent Electoral and Boundaries Commission Act, 2011 requires the Commission to submit annually, an annual report containing functions, performance on its activities, affairs and the financial statements to the President and Parliament.
- ii) Section 81 (1) (2) of the Public Finance Management Act, 2012 that requires public funds shall be used in a prudent and responsible manner

In compliance with these statutory requirements, I hereby submit to you the attached report and unaudited financial statements for the financial year that ended 30th June, 2022.

.....
W.W. Chebukati

Chairperson

INDEPENDENT ELECTORAL AND BOUNDARIES COMMISSION



30th September 2022

Hon. Moses M. Wetang'ula, E.G.H.
Speaker of the National Assembly,
Parliament buildings,
P.O. Box 4842-00100,
NAIROBI.

I have the pleasure of presenting the Annual Report of the Independent Electoral and Boundaries Commission (IEBC) for the year ending 30th June 2022.

This report has been prepared for purposes of:

- i) Article 254 of the Constitution of Kenya, 2010 and Section 24(1) of the Independent Electoral and Boundaries Commission Act, 2011 requires the Commission to submit annually, an annual report containing functions, performance on its activities, affairs and the financial statements to the President and Parliament.
- ii) Section 81 (1) (2) of the Public Finance Management Act, 2012 that requires public funds shall be used in a prudent and responsible manner

In compliance with these statutory requirements, I hereby submit to you the attached report and unaudited financial statements for the financial year that ended 30th June, 2022.

.....
W.W. Chebukati

Chairperson

INDEPENDENT ELECTORAL AND BOUNDARIES COMMISSION



30th September 2022

Hon. Amason Jeffah Kingi, EGH,
Speaker of the Senate,
Parliament Buildings,
NAIROBI.

I have the pleasure of presenting the Annual Report of the Independent Electoral and Boundaries Commission (IEBC) for the year ending 30th June 2022.

This report has been prepared for purposes of:

- i) Article 254 of the Constitution of Kenya, 2010 and Section 24(1) of the Independent Electoral and Boundaries Commission Act, 2011 requires the Commission to submit annually, an annual report containing functions, performance on its activities, affairs and the financial statements to the President and Parliament.
- ii) Section 81 (1) (2) of the Public Finance Management Act, 2012 that requires public funds shall be used in a prudent and responsible manner

In compliance with these statutory requirements, I hereby submit to you the attached report and unaudited financial statements for the financial year that ended 30th June, 2022.

.....
W.W. Chebukati

Chairperson

List of Acronyms and Abbreviations

ACII	Associate of Chartered Insurance of London
AMS	Accreditation Management System
ANC	Amani National Congress
API	Application Programming Interface
APSA	American Political Science Association
ASK	Agricultural Society of Kenya
AU	African Union
AUC	African Union Commission
BROP	Boundaries Review Operation Plan
BVR	Biometric Voter Registration
CAW	County Assembly Ward
CBO	Community Based Organizations
CBK	Central Bank of Kenya
CCSA	Certified in Control Self-Assessment
CEMs	County Elections Managers
CEO	Chief Executive Officer
CIA	Certified Internal Auditor
CISA	Certified Information Systems Auditor
CPA	Certified Public Accountant
CPS	Certified Public Secretary
CPSP	Certified Procurement and Supply Professional
CQA	Certified Quality Assessor
CRMS	Candidates Registration Management System
CRO	County Returning Officer
CS	Commission Secretary
CSR	Corporate Social Responsibility
DCRO	Deputy County Returning Officer
DRC	Dispute Resolution Committee
DRO	Deputy Returning Officer
EACC	Ethics & Anti-corruption Commission
ECC	Electoral Code of Conduct
ECDE	Early Childhood Development Education
ECVR	Enhanced Continuous Voter Registration
ELOG	Election Observer Group
EOP	Elections Operation Plan
ESAP	Election Security Arrangement Program
EVI	Electronic Voter Identification
EVV	Electronic Voter Verification
ETOC	Elections and Technical Operations Committee
FAQs	Frequently Asked Questions

GE	General Election
GPS	Global Positioning System
HR	Human Resource
HRM	Human Resource Management
ICJ	International Commission of Jurists
ICS	Institute of Certified Secretaries
ICT	Information and Communication Technology
ID	Identification Card
IEBC	Independent Electoral and Boundaries Commission
IFES	International Foundation for Electoral Support
IHRM	Institute of Human Resources Management
IIA	Institute Internal Auditor
IPOA	Independent Policing Oversight Authority
IPSAS	International Public Sector Accounting Standard
ISACA	Information Systems Audit and Control Associations
JLAC	Justice and Legal Affairs Committee
JKUAT	Jomo Kenyatta University of Agriculture and Technology
KAEM	Kenya Association of Education Administration
KCA	Kenya College of Accountancy
KEG	Kenya Editors Guild
KIEMS	Kenya Integrated Election Management System
KIM	Kenya Institute of Management
KISM	Kenya Institute of Supplies Management
KMSWG	Kenya Media Sector Working Group
KNBS	Kenya National Bureau of Statistics
KNEC	Kenya National Examination Council
KSG	Kenya School of Government
KPMG	Klynveld Peat Marwick Goerdeler International Limited
KUJ	Kenya Union of Journalists
LAN	Local Area Network
LIA	Institute of Internal Auditors
LLB	Bachelor of Laws
LSK	Law Society of Kenya
M.A	Master of Arts
MBA	Master's in Business Administration
MCA	Member of County Assembly
MCK	Media Council of Kenya
M& E	Monitoring & Evaluation
MNA	Member of National Assembly
MoU	Memoranda of Understanding
MSc	Master of Science
NCIC	National Cohesion and Integration Commission
NGCDF	National Government Constituency Development Fund

NPS	National Police Service
NSC	National Steering Committee on Peace building and Conflict Management
NRB	National Registration Bureau
ODM	Orange Democratic Movement
ODPP	Office of the Director of Public Prosecution
ORPP	Office of the Registrar of Political Parties
PAC	Parliamentary Accounts Committee
PEE	Post-Election Evaluation
PFMA	Public Financial Management Act
PFM	Public Financial Management
PPADA	Public Procurement and Disposal Act
PPAD	Public Procurement and Asset Disposal
PPDT	Political Parties Dispute Tribunal
PPE	Personal Protective Equipment
PPLC	Political Party Liaison Committee
PRSK	Public Relation Society of Kenya
PWDs	Persons with Disability
RO	Returning Officer
RoV	Register of Voters
RoVV	Register of Voters Verification
RTS	Results Transmission System
SEO	Senior Election Officer
SIGs	Special Interest Groups
SMS	Short Message Service
SOPs	Standard Operating Procedures
UK	United Kingdom
USA	United States of America
UN	United Nations
UNDP	United Nations Development Programme
UNDPK	United Nations Development Programme Kenya
UNESCO	United Nations Educational, Scientific and Cultural Organization
UoN	University of Nairobi
VEP	Voter Education Providers
WAN	Wide Area Network

About this Report

This report outlines the performance of the Independent Electoral and Boundaries Commission (IEBC) for the financial year ending 30th June 2022. It informs Kenyans – including Members of Parliament, Political Parties, Candidates, Special Interest Groups, Government Departments and Agencies, Development Partners, Media and all electoral stakeholders about activities undertaken and services provided by IEBC in the year under review.

The report describes the Commission's performance against its programs, deliverables and key performance indicators in line with the budgetary allocation for the financial year 2021/2022.

The report adheres to the requirements of Article 254 of the Constitution of Kenya, 2010, the Public Finance Management Act, 2012 and the Independent Electoral and Boundaries Commission Act, 2011.

The Report has four Sections:

1. **Preamble** – Chairman's foreword, CEO's overview and highlights for the year under review.
2. **About IEBC** – Our mandate, organization structure and programs.
3. **Performance Report and Achievements** – work and achievements for each IEBC program with key performance indicators.
4. **Financial Reporting** – financial performance for 2021/2022, includes unaudited financial statements.

These sections are supported by annexes highlighting developments, activities and outcomes.

An electronic copy of this report is available on the IEBC website:
<https://www.iebc.or.ke/resources/Publications>.

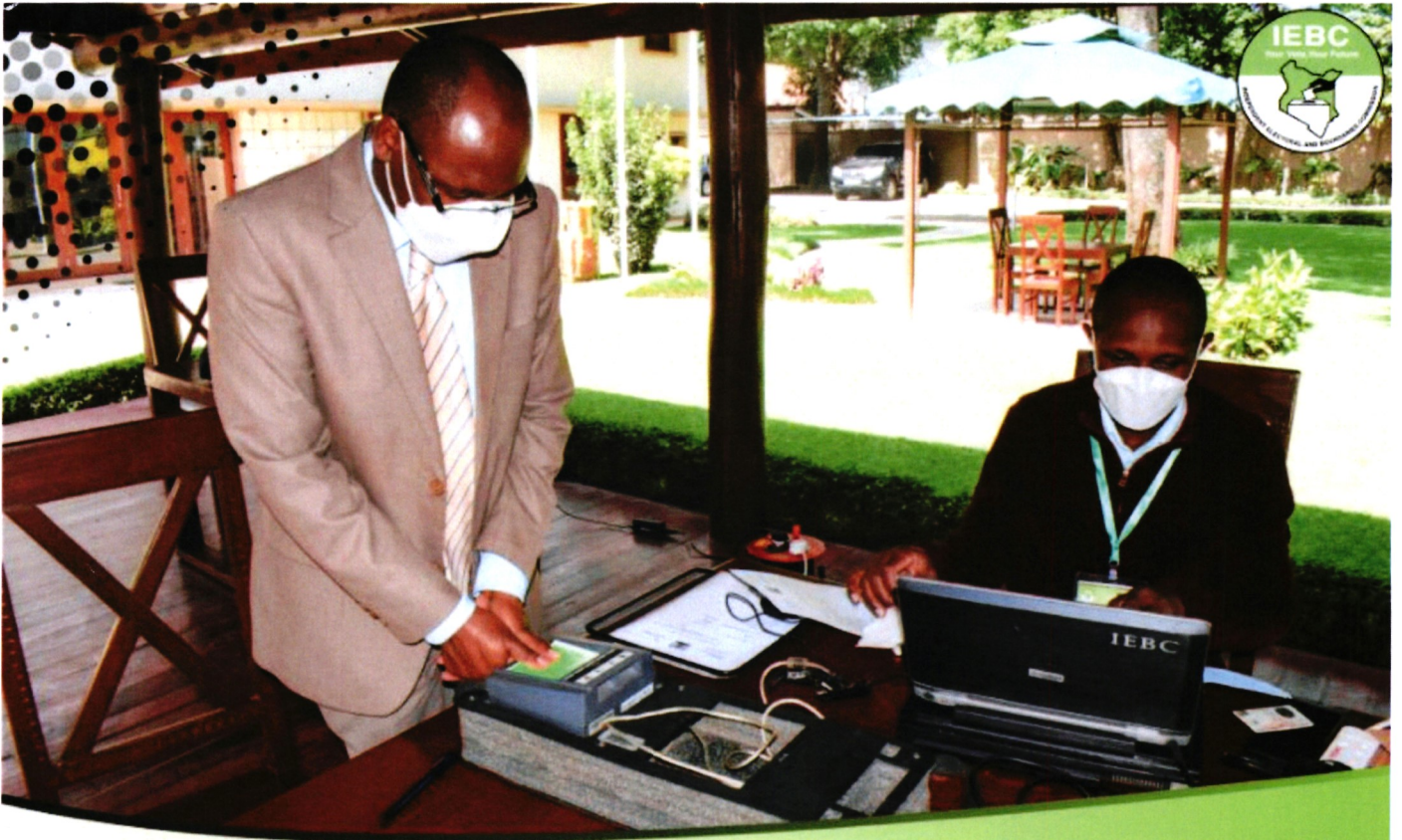

Section 1: Year in Review

Foreword



I am happy to share with you the Annual Report of the Independent Electoral and Boundaries Commission for the Financial Year 2021/2022, which caps my six-year tenure as Chairman of the Commission. The report sheds light on what we have collectively undertaken, to keep our country on the right footing as we move it towards a stronger democracy.

During the year under review, the Commission was engaged in a range of activities that had direct impact on the successful conduct of the August 9th 2022 General Election. These activities were conducted in collaboration with our strategic partners and relevant stakeholders to enhance inclusivity and public participation. Key among these activities was the roll out of Enhanced Continuous Voter Registration (ECVR) I and II at the ward level from 4th October to 5th November 2021 and from 17th January to 6th February 2021 respectively. The two exercises availed an opportunity for all eligible citizens to register as voters and exercise their political rights as provided for under Article 38 of the Constitution of Kenya. Furthermore, the decision in *Petition No. 25 of 2014 Independent Electoral & Boundaries Commission vs New Vision Kenya (NVK Mageuzi) and 4 others (2015) eKLR* directed the Commission to put in place infrastructure for the comprehensive registration of Kenyan citizens in the Diaspora as voters, to the intent that the numbers of such Kenyan citizens participating in the general election shall increase progressively over time. Pursuant to the said decision and Article 82(1)(e) the Commission added to the existing registration centres in the Diaspora (Tanzania, Uganda, Rwanda, Burundi, and South Africa) the following seven new countries: United States of America (USA), United Kingdom (UK), Canada, United Arab Emirates, Qatar, Germany and South Sudan. The registration was conducted in Kenyan Embassies, High Commissions and Consulates in the respective countries.

The Commission also conducted verification of biometric data of voters by deploying KIEMs kits at the ward level, and providing a short message service (sms) and website portal (verify.iebc.or.ke) where voters could check their registration details. Later, the Commission procured the services of KPMG to conduct an audit of the Register of voters and its recommendations were incorporated in its preparation. After the cleanup, the Commission produced an updated Register of 22, 120, 458 voters with 46,229 polling stations.

In addition, the Commission held the National Election Conference (NEC) on 11th and 12th July 2022 at the Kenyatta International Convention Centre. The Conference, that drew participants from the Election Management Bodies (EMBs) of South Africa, Ghana, Zambia, as well as partners, stakeholders and experts in the electoral process, discussed experiences in election management under the theme “Moving Kenya Towards a Stronger Democracy”.

To enhance transparency, public participation and stakeholder engagement in the electoral process, the Commission collaborated with relevant stakeholders within the confines of the law. The Commission in partnership with the National Police Service implemented the Election Security Arrangement Programme (ESAP) whose overall aim was to ensure coordinated security management for a peaceful election environment. The Commission and the National Police Service cascaded training on election security down to the constituency level that enabled the election staff and the security sector harmoniously work towards ensuring elections are conducted peacefully

within their respective jurisdictions. The Commission similarly held consultations with the Judiciary through the Judiciary Committee on Elections and discussed ways of bettering the various processes of election dispute resolutions including sensitization of Judicial Officers on the election process. In addition, Commission institutionalized scrutiny of its conduct, processes and procedures through various mechanisms that are anchored in law including observation and monitoring of elections. Through its automated Accreditation Management System (AMS) the Commission accredited domestic and international observers to undertake election observation on long and short-term for all electoral processes. The Commission equally engaged the media in order to ensure a quick flow of information in election reporting to the public. The Commission and the Kenya Media Sector Working Group (KMSWG) established the IEBC-KMSWG Joint Taskforce to sustain collaboration efforts between the two institutions. This resulted in a tripartite signing of a Memorandum of Understanding (MOU) by the Commission, Kenya Editors Guild and Kenya Union of Journalists that enabled training of media practitioners on elections and promoting access to electoral information for accurate reporting.

In conclusion, I wish to remind my fellow countrymen that we have a collective responsibility to protect the gains made towards the realization of a stronger democracy. I thank all our stakeholders and partners for the support and cooperation accorded to the Commission for the year under review and look forward to their continued assistance.

God bless Kenya.

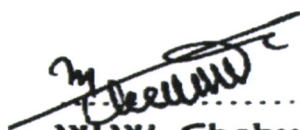

.....
W.W. Chebukati

Chairperson



The Commission Secretary's Overview

This annual report for the Financial Year 2021/2022 depicts in detail activities done during the prescribed timeframe, specifically on the implementation of the first year of the Commission's Strategic Plan 2020-2024, which has six precise pillars that include strengthening corporate governance, strengthening strategic operations, strengthening legal framework, enhanced public outreach, effective conduct of elections and equitable representation.

Generally, the Commission was successful in conducting six by-elections, which were occasioned by the death of office incumbents despite the adverse effects of Covid-19 pandemic. This thrusts to the fore the quick implementation of the Strategic Plan 2020-2024, where the Commission moved out and rolled the Enhanced Continuous Voter Registration (ECVR). This is a crucial exercise in the run up to the August 9th, 2022, General Election.

Moreover, the Commission held consultative processes to update the electoral geo-database in preparation for the delimitation exercise as outlined in the Boundary Review Operations Plan, 2019-2024. During the review period, the Commission undertook the sub-locations boundary data collection exercise, which is critical in the delimitation of electoral boundaries. As a result, the Commission updated its electoral geodatabase in 38 Counties. The exercise revealed that 1,864 gazzetted and operationalized sub-locations have been delimited since 2012. This number is expected to rise once the sub-location boundaries data is collected for the remaining nine counties.

In our quest to improve operation processes in the year 2021/2022, the Commission developed Standard Operation Procedures, Policies and Manuals to have a coordinated approach in the implementation of Commission, mandate, activities and programs.

More so, the Commission is committed to attract, develop, and retain highly skilled and motivated staff to implement its mandate. During the Fiscal Year 2021/2022, the Commission advertised, conducted interviews, and recruited competent staff in critical positions within its establishment including that of Commission Secretary/CEO and two Deputy Commission Secretaries for Election Operations and Support Services. This is besides the appointment of the Directors for Information and Communication Technology, Legal Services, and Research, Electoral Boundaries and Risk Management respectively.

Going forward, the Commission has adopted modern and dynamic styles to guide in its registration of voters, communication, and management of its daily operations as per world's best practices. Moreover, as part of its Corporate Social Responsibility (CSR), the Commission was involved in conduct of several primary schools, High schools, tertiary and the Law Society of Kenya elections. These activities and elections, at the grassroot level, provide the Commission with the human touch to serve the community, and in the process, be able to enhance its voter education and instill democratic principles to our children at early ages.

In conclusion, it imperative to note that operations of Commission activities are hinged on the funding from the National Treasury, however, such has of late been curtailed by long delays leading

to slow down in some of the projects that are time bound. My appeal to the Government is to fast-track funds provisions throughout the electoral cycle to enable the Commission to fulfill its constitutional mandate.

We are also cognizant and indebted to the efforts and support of our staff, stakeholders and partners, which has enabled the Commission to implement its work plan within the set timelines.

I beseech everyone to consider reading this 2021/2022 Annual Report in order to familiarize with the Commission's activities, achievements, and challenges, which may impact on the conduct of the forthcoming August 9th, 2022, General Elections and the Electoral Boundaries Delimitation Exercise.

A handwritten signature in black ink, consisting of a large, sweeping loop followed by several vertical strokes and a final flourish.

Marjan Hussein Marjan

Commission Secretary/Chief Executive Officer.

THE COMMISSION

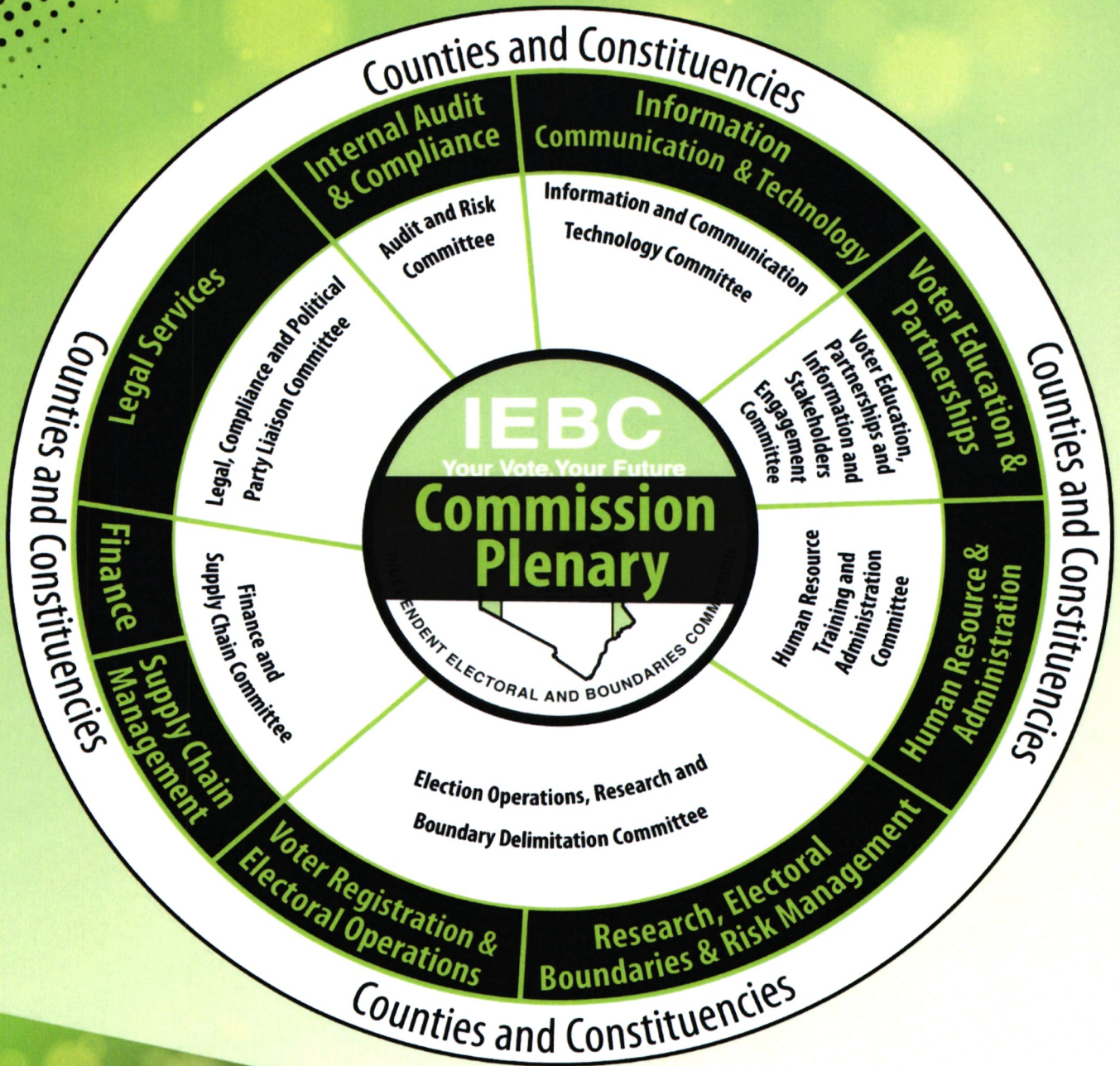



Section 2: About the Commission

**ANNUAL
REPORT**
2021/2022

2.1 The Commission

The Independent Electoral and Boundaries Commission is established under Article 88(1) and incorporated as a body corporate under Article 253 of the Constitution of Kenya, 2010.

2.2 Our Mandate

The Commission is mandated under Article 88(4) of the Constitution of Kenya, 2010 to conduct or supervise referenda and elections to any elective body or office established by the Constitution, and any other elections as prescribed by an Act of Parliament. The IEBC is specifically responsible for:

- a) The continuous registration of citizens as voters;
- b) The regular revision of the voters' roll;
- c) The delimitation of constituencies and wards;
- d) The regulation of the process by which parties nominate candidates for elections;
- e) The settlement of electoral disputes, including disputes relating to or arising from nominations, but excluding election petitions and disputes subsequent to the declaration of election results;
- f) The registration of candidates for election;
- g) Voter education;
- h) The facilitation of the observation, monitoring and evaluation of elections;
- i) The regulation of the amount of money that may be spent by or on behalf of a candidate or party in respect of any election;
- j) The development and enforcement of a code of conduct for candidates and parties contesting elections; and
- k) The monitoring of compliance with the legislation required by Article 82 (1) (b) of the Constitution relating to nomination of candidates by parties.

2.3 The Legal Framework

The Commission derives its mandate, purpose, values and leadership capabilities and conduct of its activities from the Constitution of Kenya, 2010, and other legislative and administrative instruments shown in Table 1.

Table 1: The Legislative Framework

Legislative Instrument	Functions of the Legislative Instrument
The Constitution of Kenya, 2010	The Constitution is the supreme law of the Republic and binds all persons and all State organs at both levels of government.
The Independent Electoral and Boundaries Commission Act, 2011	<ol style="list-style-type: none">i) Provides for the operations, powers, responsibilities and functions of the Commission to supervise referenda and elections to any elective body or office established by the Constitution or any other Act of Parliament.ii) Maintaining and updating the register of votersiii) Promoting public awareness of electoral and parliamentary

Legislative Instrument	Functions of the Legislative Instrument
	<p>matters through information and education programs</p> <ul style="list-style-type: none"> iv) Providing international electoral assistance v) Conducting Boundary delimitation and review of wards vi) Conducting and promoting research into electoral matters and other matters that relate to IEBC functions
Elections Act, 2011	<p>The Act stipulates the procedures to be followed during elections including registration of voters, rules and regulation on nomination of candidates for elections and referendum process, it provides for the code of conduct for election officials, political parties and dispute resolution among other provisions.</p>
Political Parties Act, 2011	<p>The Act established under Article 91 and 92 of the Constitution of Kenya by and large describes;</p> <ul style="list-style-type: none"> i) The formation of Political parties, ii) Requirements of Political Parties, iii) Registration, iv) Deregistration, v) Rights and privileges of Political Parties, vi) Funding of Political Parties, and vii) Offences. <p>The Act establishes the Political Parties Disputes Tribunal (PPDT) to determine disputes emanating from Political Parties. The Act also establishes the Office of the Registrar of Political Parties (ORPP) as a state office as prescribed in Article 260 of the Constitution among others.</p>
Election Campaign Financing Act, 2013	<p>The purpose of this law is to, among other things, promote good governance and a sustainable democratic political system, raise awareness and promote transparency in political party financing, reduce inequality of political parties during elections and to provide an even playing field for all political parties, safeguarding against the use of illegal resources to promote interests of candidate or political parties in party nominations and elections and make political parties accountable to their members.</p>
Election Offences Act, 2016	<p>The Act provides for election offences and the punishments. They include among others:</p> <ul style="list-style-type: none"> i. Offences touching on the register of voters ii. Offences relating to voting

Legislative Instrument	Functions of the Legislative Instrument
	<ul style="list-style-type: none"> iii. Offences by members and staff of the Commission iv. Bribery v. Unlawful expenditure and vi. Maintenance of secrecy at elections. <p>It also prescribes who are liable and who has the authority to prosecute the offences under the Act.</p>
<p>The Election Regulations</p>	<p>Section 109 of the Elections Act, 2011 empowers the Commission to make regulations for the better carrying out of its mandate. To date, the Commission is guided by the following seven regulations.</p> <ul style="list-style-type: none"> i. Elections (Registration of Voters) Regulations, 2012. ii. Elections (General) Regulations, 2012. iii. Elections (Technology) Regulations, 2017. iv. Elections (Party Primaries and Party Lists) Regulations, 2017. v. Elections (Voter Education) Regulations, 2017. vi. Rules of Procedure on Settlement of Disputes. vii. Guidelines on the Nomination of Candidates, 2017.

Other enabling legislations include.

- i) The Public Finance Management Act, 2012.
- ii) Freedom of Information Act, 2012.
- iii) Public Service Commission Act, 2012.
- iv) Public Service (Values and Principles) Act, 2015.
- v) Leadership and Integrity Act, 2012.
- vi) Public Procurement and Asset Disposal Act, 2015.
- vii) District and Provinces Act, 1992.
- viii) The County Government Act, 2012.
- ix) Survey Act, 2012.
- x) Statistics Act, 2006.
- xi) Data Protection Act, 2019.
- xii) Public Officers Ethics Act, 2003.

2.4 Organization

The Independent Electoral and Boundaries Commission (IEBC) is structured into the Commission and the Secretariat.

2.5 The Commission

The Commission consists of a Chairperson and six members who are appointed as per Article 250 of the Constitution. The principal role of the Commission is to formulate policy, provide strategy and oversight the Secretariat.

2.5.1 Members of the Commission



Wafula W. Chebukati
Chairman of the Commission

Qualification

- Master of Business Administration from Jomo Kenyatta University of Agriculture and Technology (JKUAT).
- Bachelor of Laws (LLB) Degree from the University of Nairobi.
- Post Graduate Diploma from the Kenya School of Law.

Experience

- Over 36 years' experience in legal practice.
- Works on a full-time basis as the Chairperson of the Commission
- President of the Association of African Election Authorities' General Assembly.
- Membership:
 - Law Society of Kenya (LSK)
 - Institute of Certified Secretaries (ICS)
 - International Commission of Jurists (ICJ) -Kenya



Juliana Cherera

Qualifications

- Master of Education, Leadership and Educational Management from Kenya Methodist University.
- Bachelor of Education (Arts). Honours from Kenyatta University.
- Project Management; KIM.
- Early Childhood Development Education (ECDE); KNEC.
- Strategic Leadership and Development Program; KSG
- Senior Management Course (SMC); KSG

Experience

- Ms Cherera Has over 18 years' experience in Education and Management in the public sector.
- Before her appointment to the Commission, she worked as Chief Officer Executive in the Strategic Delivery Unit of the Mombasa County Government.
- Member of Mombasa County Emergency Household Relief and Nutrition Support Project Coordination Committee.
- Secretary to the Mombasa County Economic Recovery and Legacy Strategy.
- Member of Kenya Devolution Support Program Committee.
- Works on a full-time basis as a vice chairperson of the Commission.
- She Chairs the Voter Education, Partnerships and Stakeholders Engagement Committee.

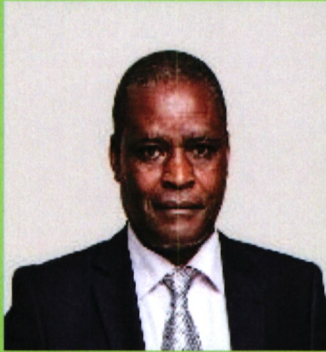

Francis Wanderi

Qualification

- Master of Science in Management (MSc. Mgmt.); from Arthur D. Little Management Institute at Boston, USA.
- Bachelor of Education; UoN.
- Transformative Leadership and Change Management.
- Corporate Governance Course by Commonwealth Association for Corporate Governance.

Experience

- Over 32 years in senior management within public and private institutions characterized by integrity and a high performance, and with a proven track record in development and execution of strategy, people and change management and, leadership and innovation toward realization of organizational objectives and visions.
- Francis M. Wanderi is a former Chairperson of EPZ and director Roots Credit Ltd.
- He Chairs Finance and Supply Chain Management Committee.

Qualification

- Master of Arts (M.A) Education from the Institute of Education, University of London (IOE), UK.
- Diploma in Leadership, Governance, Peace and Conflict Transformation from the United Nations' University -International Leadership Academy in Jordan -Amman.
- He studied educational science in Kenya and Great Britain.

Experience

- Nyang'aya has over 32 years of experience in Strategic Leadership, Governance and Social Accountability Organizations
- He was director of Lead Africa, an organization working for the Qualification of African Managers.
- Former Country Director, Amnesty International Kenya. Amnesty Kenya's work concentrates on the prevention of forced evictions, the protection of housing rights and women's rights.
- He also worked for the Netherlands Development Organization as well as UNESCO.
- Chairs the Information and Communication Technology Committee.

Qualifications

- Master's degree in Strategic Human Resource Management from the University of Manchester, UK.
- Bachelor of Law degree from the University of Nairobi.
- Bachelor of Arts degree in social work from the University of Nairobi.
- Post Graduate Dip from Kenya School of Law.
- Member of International Certified Addiction Professional (ICAP I-Treatment; Colombo Plan Global Centre for Credentialing and Certification.
- Member of Institute of Internal Auditors (IIA).

Experience

- Irene Masit has over 25 years work experience and knowledge in Government and Non – Governmental Organizations.
- She is the immediate former board member, National Government Constituency Development Fund (NGCDF).
- She has knowledge and experience in Finance, Governance, Management and Public Administration.
- Chairs the Legal, Compliance and Political Party Liaison Committee and the Leadership and Integrity Committee.



Justus Nyang'aya



Irene Masit



Prof. Abdi Yakub Guliye

Qualification

- PhD in Animal Nutrition from Rowett Research Institute/ University of Aberdeen, Scotland, UK.
- Master of Science in Animal Production from University of Aberdeen, Scotland, UK.
- Bachelor of Science in Animal Production from Egerton University.

Experience

- Guliye has over 27 years of university teaching experience, of which in the last 7 years he had additional administrative/ managerial roles. He also served in various Boards of Institutions/Organizations, having chaired committees such as Audit and Risk Management as well as Finance.
- Chairs the Election Operations, Research and Boundary Delimitation Committee.



Boya Molu

Qualification

- Masters in Business Administration (HR Management Option), Periyar University, India.
- Bachelor of Business Administration from Karnatak University, India.
- Higher National Diploma in Human Resources Management (KNEC), IHRM Kenya.

Experience

- Has over 17 years' experience in Human Resource Management and administration mainly in public sector.
- Mr. Molu started public service career at the Central Bank of Kenya (CBK) and later joined the Judiciary where he rose through the ranks to the position of Deputy Director Human Resources and Administration. Subsequently appointed Commissioner IEBC in January 2017.
- Also served as a council member of the Institute of Human Resources Management (IHRM) Kenya for 4 years.
- Chairs the Human Resource, Administration and Training Committee.

2.5.2 The Secretariat

The Secretariat consists of the Commission Secretary/CEO and employees of the Commission. The CEO is the head of the Secretariat and Accounting Officer. The CS/CEO is deputized by two Deputy Commission Secretaries in charge of Support Services and Operations.

The Secretariat is structured into nine directorates as follows:

- i. Voter Registration and Electoral Operations,
- ii. Voter Education, Partnerships and Communication,
- iii. Information and Communication Technology,
- iv. Finance Management,
- v. Legal Services,
- vi. Research, Electoral Boundaries and Risk Management
- vii. Human Resource and Administration,
- viii. Internal Audit and Compliance, and
- ix. Supply Chain Management.

The directorates are charged with the responsibility of developing and overseeing implementation of Commission's programs in accordance with existing laws, regulations and procedures.

For effective service delivery and efficient implementation of activities and programs, the Commission has established offices at County and Constituency levels headed by County Elections Managers and Senior Elections Officers respectively.



Marjan H. Marjan
Commission Secretary/CEO

Qualifications

- MBA in Strategic Management - University of Nairobi (UoN).
- BCom (Accounting Option) - (UoN).
- Certified Public Accountant (CPA-K).
- Certified Information Systems Auditor (CISA).
- Certified Internal Auditor (CIA).
- Certification in Control Self-Assessment (CCSA)
- Certified Quality Assessor (CQA)
- Practicing Member of ICPAK in good standing.
- Member of Information Systems Audit & Control Association (ISACA)
- Member of Institute Internal Auditor (IIA)



Obadiah K. Keitany
Deputy Commission Secretary -
Support Services

Qualifications

- MBA Finance – University of Nairobi (UoN).
- B. Com Insurance (UoN)
- Certified Public Accountant (CPA-K).
- Certified Internal Auditor (CIA).
- Certified Information Systems Auditor (CISA).
- Certified Public Secretary (CPS-K).
- Certified Quality Assessor (CQA).
- Post Graduate Diploma in Corporate Governance (KCA).
- Member of ICPAK in good standing.
- Member of Information Systems Audit & Control Association (ISACA).
- Member of Institute of Internal Auditors (IIA).
- Member of Institute of Certified Secretaries of Kenya.



Ruth Kulundu
Deputy Commission Secretary -
Operations

Qualifications

- Master of Business Administration (MBA) - Strategic Management UON
- Bachelor of Commerce (B. Com) - UON
- Associate of Chartered Insurance of London (ACII) and Kenya (AIK)
- Associate of Chartered Institute of Arbitrators (Kenya Chapter)



Moses Sunkuli

Director Voter Registration and Electoral Operation

Qualifications

- MBA Strategic Management.
- Bachelor of Arts Education, Moi University.
- Diploma in Business Management, Kenya Institute of Management (KIM).
- Certificate in Management of Democratic Elections, UNISA.
- Member, Kenya Institute of Management.



Rasi Masudi

Director Voter Education, Partnerships and Communication

Qualifications

- Executive Master of Business Administration (MBA).
- Bachelor of Science in Agricultural Economics.
- Diploma in Farm Management.



Harley Kisyula Mutisya

Director Supply Chain Management

Qualifications

- PHD in Business Administration (UoN)
- MBA in Procurement & Supply Chain Management (UoN)
- BCOM in Supply Chain Management (UoN)
- Diploma in Logistical Management from Cerford Institute.
- Certified Procurement and Supply Professional (CPSP-K)
- Chartered Associate (ACI Arb)
- Member Kenya Institute of Supplies Management (KISM)
- Certified Practitioner-(KISM)
- Fellow Logistics Society of Kenya
- Member Chartered Institute of Procurement and Supply (UK)



Osman H. Ibrahim
Director Finance

Qualifications

- Master's in business administration in Finance (MBA)
- Bachelor of Commerce from the University of Nairobi.
- Certified Public Accountant.
- Member of ICPAK in good standing.



Chrispine Owiye
Director Legal Services

Qualifications

- Advocate of the High Court of 18 years post admission experience and in good standing
- A Commissioner for oaths
- A notaries Public
- Member of:
 - Law Society of Kenya
 - International Commission of Jurists
 - International Police Association



Dr. Catherine M. Kamindo
Director Research Electoral
Boundaries & Risk Management

Qualifications

- PhD Education Policy and Management- University of Durham (UK)
- Master of Education Educational Administration- Kenyatta University
- Bachelor of Education- Kenyatta University
- Certificate in Strategic Communication- The World Bank
- Certificate in Management of Democratic Elections in Africa- University of South Africa
- Professional Certificate in Electoral Processes-International Centre for Parliamentary Studies (UK)
- Full Member (FKIM) Kenya Institute of Management.
- African Union Certified Long and Short-Term Elections Observer.
- Member of Kenya Association of Educational Administration (KAEM).
- Member of the American Political Science Association (APSA)



Michael Ouma
Director Information
Communication and Technology

Qualifications

- MBA, Strategic Management - UoN
- Bachelor of Technology in Electrical & Communications Engineering – Moi University



Name: Lorna A. Onyango
Director Human Resource and
Administration

Qualifications

- Certified Human Resource Professional.
- Masters in Human Resource Management.
- Bachelor of Arts Degree (UoN).
- Post Graduate Diploma.



Name: Reuben Chirchir
Ag. Director Audit & Compliance

Qualifications

- Masters in Business Administration in Finance (MBA)- USIU;
- Bachelor of Arts, BA(Hons), Economics - University of Nairobi.
- Certified Public Accountant (CPA-K);
- Member of ICPAK in good standing.
- Member of IIA-Kenya in good standing.

Figure 1: Organization Structure

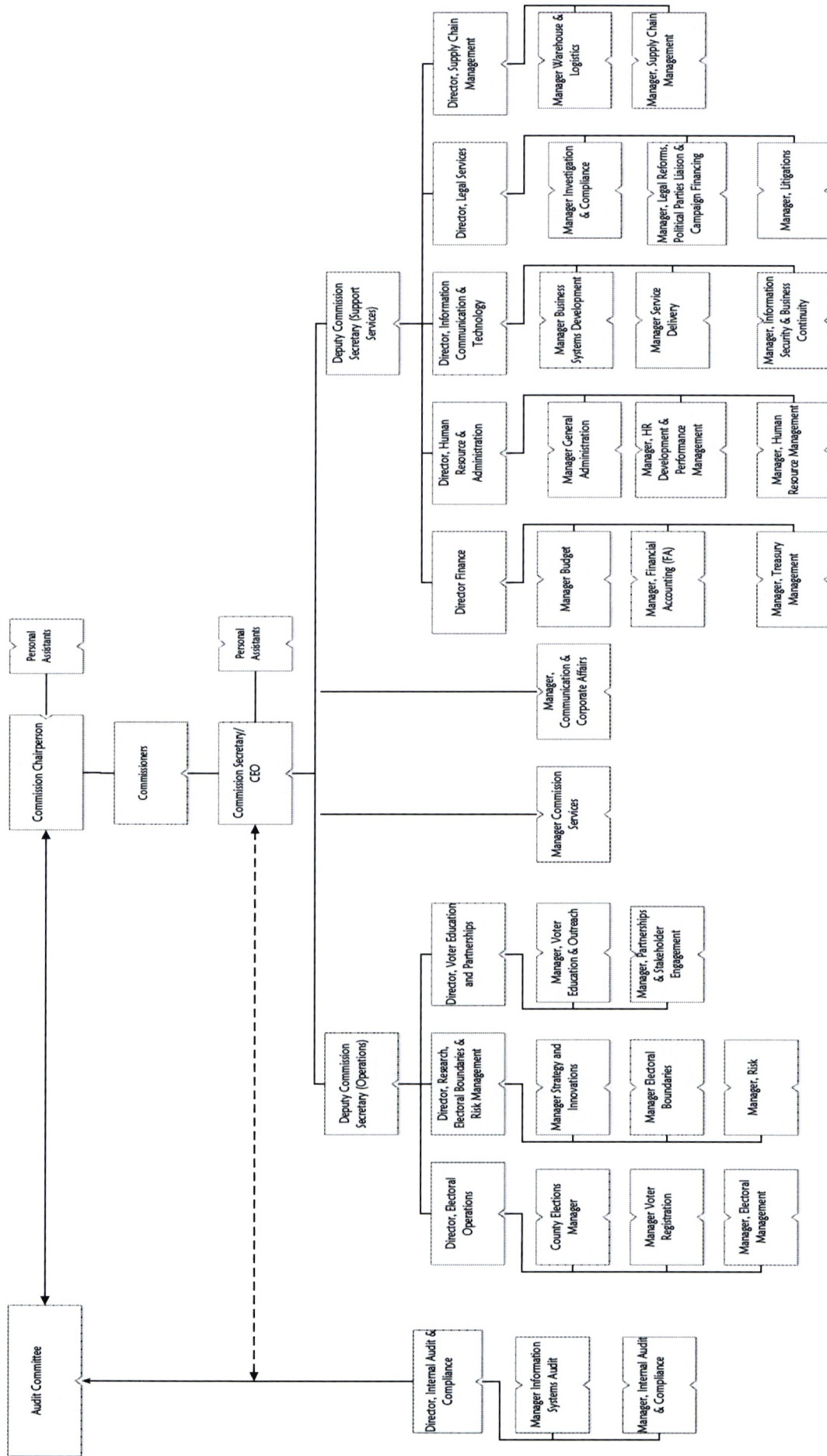

2.6 The Commission Governance Structure

The Commission governance structure comprises of the Plenary (Board) and Committees.

2.6.1 Plenary

The Plenary consists of the Chairman and the six Commissioners. In order to execute its constitutional mandate, the Plenary has scheduled monthly meeting. In the year under review, the Commission held 18 meetings.

2.6.2 Committees

There are seven Commission Committees that are responsible for decision on policy issues. The Committees' decisions are presented to the Plenary for approval. The Committees are chaired by Commissioners with exception of the Audit and Risk Committee that is chaired by an external person appointed from outside the Commission. Directors attend the relevant committee meeting on invitation. In the year under review, a total of 24 Committee meetings were held. Figure 2 shows the Commission's Committees.

2.7 The IEBC Strategic Plan 2020-2024

The 2020-2024 Strategic Plan is hinged on six Strategic focus areas as shown in *Figure 3*. In order to operationalize the strategic plan, the Commission developed the Elections Operation Plan, the Boundaries Review Operation Plan, Standard Operating Procedures (SOPs) and Manuals that guide the day-to-day activities of the Commission.

Figure 2: Focus Areas of the 2020-2024 IEBC Strategic Plan

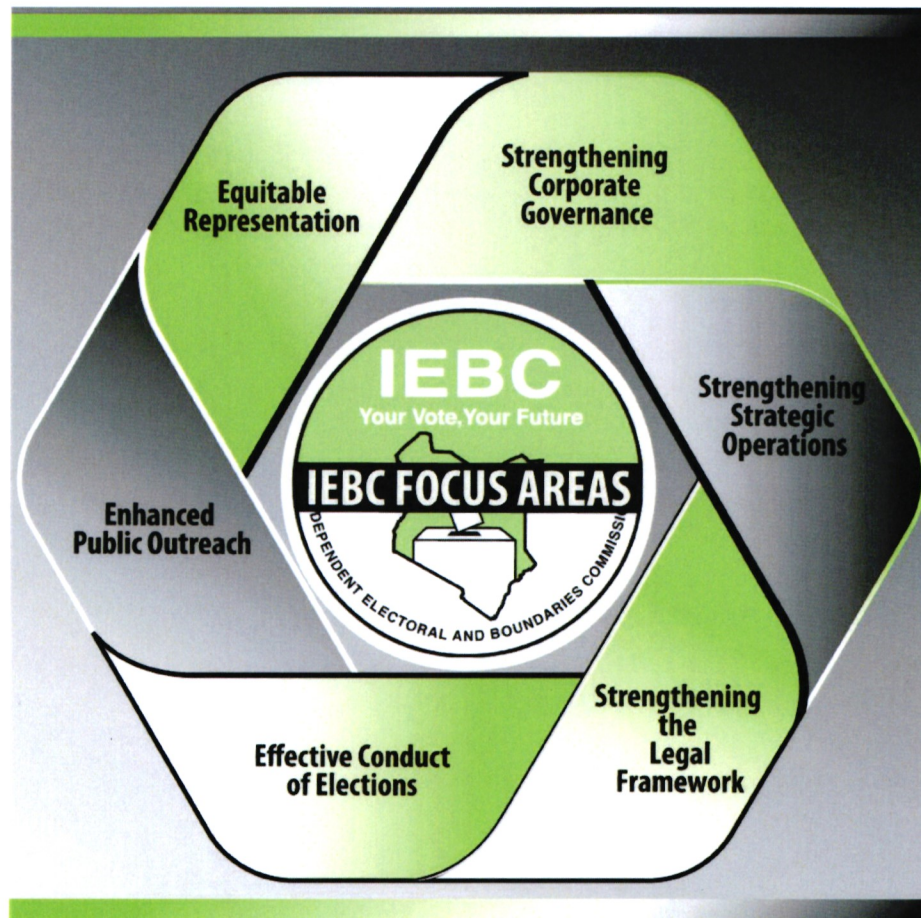

The Election Operation Plan (EOP)

The EOP is a key navigation instrument to steer the execution of key electoral activities in the 2022 General Election. It provides implementation schedules, activities and timelines.

Boundaries Review Operation Plan (BROP)

The BROP details procedures, processes, tasks, activities, timelines and the budget for the electoral boundaries delimitation exercise.

Standard Operating Procedure and Manuals

Standard Operating Procedures (SOPs) and manuals: these are written procedures and instructions that describes the step-by-step process that must be taken to properly perform a routine activity in the Commission so as to ensure consistency and compliance with industry regulations and business standards.

Figure 3: IEBC Planning and Reporting Framework

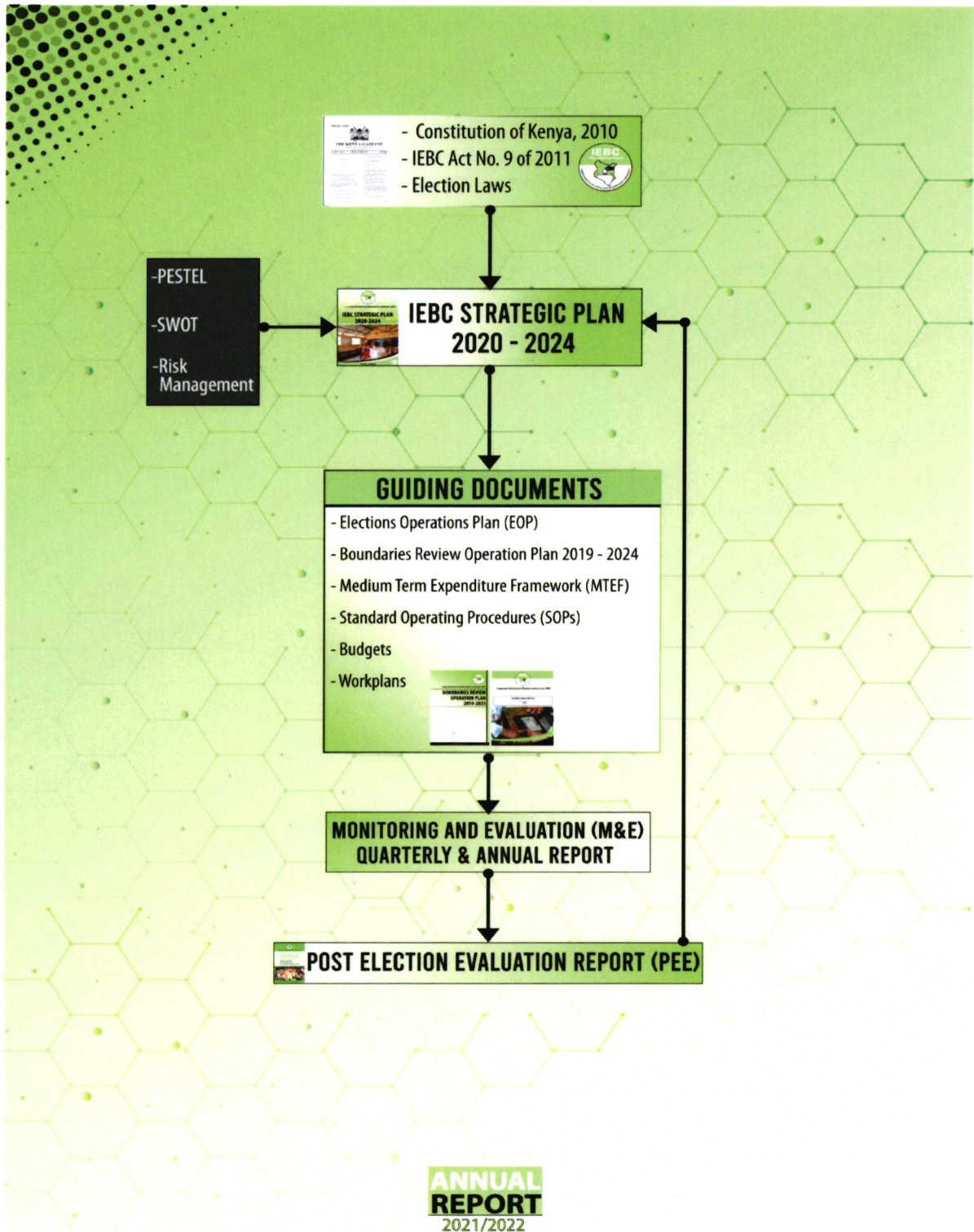

2.8 Structure of the IEBC Programmes

The Commission endeavors to achieve the following strategic outcomes:

Outcome 1: Meet the democratic aspirations of the people of Kenya.

Outcome 2: Equitable representation and sustainable democracy.

The outcomes are realized through the two Commission programmes as shown in Table 2.

Table 2: Structure of the IEBC Programmes

Programme 1. Management of Electoral process in Kenya	Programme 2. Delimitation of electoral boundaries
Objective	Objective
To deliver free, fair and credible elections	To promote equity in representation and participation in the electoral process

These programmes are realized through the Commission's six key result areas namely;

- i) Strengthening Corporate Governance,
- ii) Strengthening Legal Framework,
- iii) Effective Conduct of Elections,
- iv) Public Outreach, Effective Voter Education and Strategic Partnership, Collaboration and Communication,
- v) Equitable Representation, And
- vi) Strengthening Strategic Operations.

In the next section, the report presents the Commission's performance based on the six key result areas.



Section 3 - Performance Information by Programme



3 PERFORMANCE INFORMATION BY PROGRAMME

3.1 Key Result Area#1: Strengthening Corporate Governance

The Commission is accountable to the public and stakeholders through Parliament for ensuring that it complies with the highest standards of corporate governance and operational ethics. The Commission embraces corporate governance by promoting the right corporate culture and values.

The Commission delegates certain functions to committees without abdicating its own responsibilities. The Commission has a committee structure that assists in the execution of its duties, powers and authorities. The Committees are appropriately constituted drawing membership from amongst the Commissioners with the appropriate set of skills and experience and directors co-opted from various directorates.

Figure 4: Commission Committees

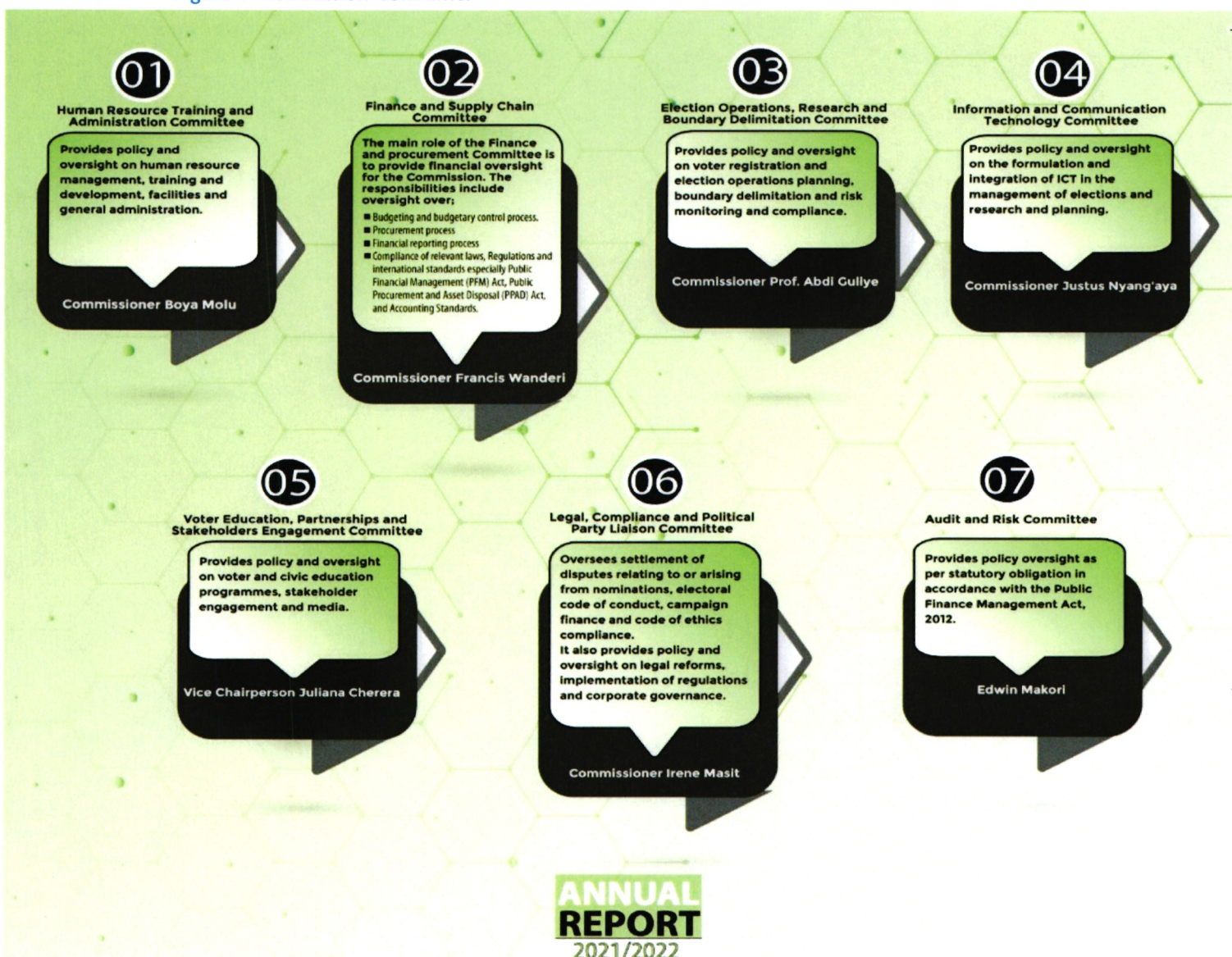

a) Commission Policy Decisions

During the period under review, the Commission held 11 management meetings followed by committee meetings whose resolutions were passed on to the Plenary (Board) for approval. The Plenary held 10 meetings that culminated into strategic policy decisions. Key policy decisions resolutions included;

- i) The expansion of diaspora registration centers and use of IDs during Diaspora voter registration.
- ii) Signing of MoUs with stakeholders such as Sign TV, Kenya Media Stakeholder working groups.
- iii) Updating of sub-location geodatabase in 38 counties in preparation for electoral boundaries delimitation set for the next financial year.
- iv) Two enhanced continuous voter registration (ECVR) drives.

b) Internal Audit

Internal Audit is tasked with a responsibility of providing independent Assurance objective and consulting activities designed to add value and improve processes and operations of the Commission by evaluating the effectiveness of risk management, control and governance process.

During the year under review, the audits for various activities and processes were conducted as shown in the Table 3

Table 3: Audits for Commission Activities

Performance Indicator	Planned Target 2021/2022	Actual Achievement 2021/2022	Remarks
Internal audit of Commission's activities and processes	Audit 14 Commission activities and processes.	10 audit reports issued.	Enhanced control environment

c) External Audit

The Commission in compliance with the PFM Act, subjected its processes to External Audit. The Office of the Auditor-General conducted the audit to establish whether public money was utilized lawfully and optimally in an effective way, and reports were submitted to Parliament for any appropriate action.

d) International Liaisons and Collaborations

To improve on delivery of its mandate, the Commission has inculcated peer learning culture to benchmark on best practices in electoral management. During the period under review, the Commission participated in the following local and international conferences and Election Observation Missions as shown in Table 4.

Table 4: International Liaisons and Collaborations

S/No.	Location	Dates	Event	Purpose
1.	Dar ES salaam	25-28 th	Joint EAC-UN DPPA Electoral	Workshop on

	Tanzania	October, 2021	workshop	elections
2.	Venezuela	17-22 nd , November 2021	International Electoral Oversight Plan of the Regional and municipal elections of Venezuela	Election observation
3.	Germany, Dubai, Qatar, Canada, UK, USA, South Sudan	21 Nov- 2021, Dec	Mapping of voter registration centers in the Diaspora;	Mapping of registration centers
4.	Zanzibar	22-27 November, 2021.	26 th Annual East African Law Society Annual Conference & General Meeting	Annual Conference & General Meeting
5.	Accra Ghana	12-14 May, 2021	Executive committee meeting of the Association of African Elections Authorities (AAEA)	

e) Induction of New Commissioners

During the period under review, the Commission with the support of International Foundation of Electoral Systems (IFES) inducted the newly appointed Commissioners. The induction prepared them on their role regarding policy and oversight in election management. Four new Commissioners; Juliana Cherera, Francis Wanderi, Irene Masit and Justus Nyang'aya were sworn in on 2nd September 2021.



IEBC with support from International Foundation for Electoral Systems (IFES) organized capacity building programme for the Commissioners and Senior Management on electoral leadership and

3.2 Key Result Area#2: Strengthening the Legal Framework

In the period under review, the Commission deployed strategies and advisories towards mitigation and resolution of disputes. Further, the Commission managed and supervised litigation that arose against the Commission or instituted by the Commission on its own behalf. The Commission undertook legislative legal reform initiatives and ensured compliance with the set constitutional and statutory framework.

Table 5: Strengthening Legal Framework

Performance Indicator	Actual Achievement 2020/2021	Planned Target 2020/2021	Actual Achievement 2020/2021	Remarks
All Electoral Laws reviewed and harmonized	<ul style="list-style-type: none"> Finalization and Submission of the comprehensive matrix of proposals to JLAC on the electoral reform agenda. Submission of the amendment bills to Parliament for validation and enactment. 	<ul style="list-style-type: none"> Follow up finalized and submitted the following bills to Parliament; Draft Referendum, Bill 2020 Draft Referendum Regulation Bill, 2020 Draft Election Campaign Financing Regulations Bill, 2020 Draft Election Campaign Financing (Amendment) Bill, 2020. IEBC (Amendment) Bill for boundaries delimitation 	<ul style="list-style-type: none"> Followed up on Draft Bills awaiting tabling before Parliament. Comprehensive Matrix of Proposals developed, and draft bill discussed with Stakeholders. Submitted the following draft bills to parliament. Presented the following Draft Regulations to Parliament. Draft Elections (General) Regulations, 2022 Draft Elections (Voter education) Regulations, 2022 Draft Elections (Technology) Regulations, 2022. Draft (Registration of voters) Regulations, 2022 Draft Elections (Party Primaries and Party Lists) Regulations, 2022 	Pending Parliamentary approval.
Percentage of reported cases of violation of the electoral code of conduct.	100% of cases reported heard and determined.	Hear and determine all cases reported.	100% of cases reported, heard and determined.	
Percentage of Political Parties compliant with the law	Ensure all registered political parties compliant.	90% of all registered political parties compliant.	98% of all registered political parties compliant	Commission enhanced regulation and enforcement of Electoral Code of Conduct in all by-elections conducted.
Percentage development of the Case	Approved case management system	100%	100%	Fully operationalized

Performance Indicator	Actual Achievement 2020/2021	Planned Target 2020/2021	Actual Achievement 2020/2021	Remarks
management System				
Gaps identified in how Commission contracts are handled.	Approve contract management framework	Contract management framework approved	Contract Management Framework implemented	Target Achieved.
Percentage of legal advisories drawn.	100% considered legal opinions timeously issued to the Commission on emerging electoral matters.	Service all requested legal advisories.	100% requested legal advisories serviced.	
Percentage of Notices published in line with statutory provisions.	All Gazette Notices published in respect of by-elections and party- lists matters.	Timely publication of Gazette Notices.	100% Gazette notices published as required by statute on various electoral aspects.	
100% of disputes heard and determined.	Complaints filed and adjudicated within the stipulated time.	Adjudicate 325 complaints filed before the Dispute Resolution Committee (DRC) within timelines set by law.	100% of the disputes heard and determined by the IEBC Dispute Resolution Committee	
Compliance with Chapter 6 of the Constitution	Percentage of aspirants vetted by Chapter Six Working Group	100 % vetted	21,863 aspirants were vetted	
Informed decision on reported cases	Percentage of cases reported against violation of the Electoral Code of Conduct resolved	100%	3 cases were reported, investigated and prosecuted.	
	Percentage of reported cases investigated	100%	29 cases were reported and successfully investigated.	

3.2.1 Electoral Legal Reform



IEBC Commission Secretary/CEO, Marjan H. Marjan, is sworn in at the Supreme Court. The ceremony was presided over by the Chief Justice Martha Koome.

During the period under review, the Commission in collaboration with the national Assembly Justice and Legal Affairs Committee (JLAC), engaged in review of electoral laws that saw the publication of the Election Laws (Amendment) Bill, 2022 which was passed by the National Assembly and is still pending discussion in the Senate.

Additionally, the Commission finalized and forwarded to Parliament the following draft regulations to improve the electoral statutory framework;

- Draft Elections (General) Regulations, 2022.
- Draft Elections (Voter education) Regulations, 2022.
- Draft Elections (Technology) Regulations, 2022.
- Draft Elections (Registration of voters) Regulations, 2022 and
- Draft Elections (Party Primaries and Party Lists) Regulations, 2022.

3.2.2 Investigation and Prosecution

During the year under review, the Commission in collaboration with the Office of the Director of Public Prosecutions (ODPP), National Police Service (NPS) and other relevant agencies investigated thirty-five (35) cases. Annex 2 shows the nature of the case and where the offence was committed.

3.2.3 Contract Development and Management

The Commission contractually engages suppliers of goods and services. During the year under review, the Commission prepared contracts for the supply and delivery of different goods and services to enable the conduct the general election as shown in Annex 3.

3.2.4 Execution of Leases

The Commission engages in contractual agreements for office spaces and/or warehouses. In the period under review, tenancy agreements were executed at the Commission as shown in Annex 4.

3.2.5 Legal Advisories on Issues Affecting the Commission

The Commission receives and considers legal opinions which inform policy direction on electoral practices and processes. In the year under review, the Commission had the following legal advisory opinions drawn on various electoral issues as highlighted in Table 6.

Table 6: Commission's Legal Advisory Opinions

NO.	TITLE OF OPINION
1.	Legal advisory on deceased candidates immediately before and/or after close of nominations.
2.	Legal advisory on withdrawal of candidates after nominations
3.	Advisory on Withdrawal of deputy governors/running mates after close of nominations
4.	Advisory on change of names of candidates with new identity cards after nominations with old identification nominations.
5.	Legal opinion on suspension of registration of voters
6.	Legal advisory on submission of supporters for independent candidates
7.	Advisory on plagiarism in political party's slogans and manifestos
8.	Advisory on by-election timelines for Khasoko Ward in Bumula Constituency
9.	Legal advisory on the nature of referendum questions

3.2.6 Gazette Notice Publication

Section 27(1) of the IEBC Act, 2011 requires the Commission to publish all important information within its mandate affecting the nation. In the period under review, the Commission published and publicized information on various issues. The details are shown in Table 7. Annex 5 gives further details of gazette notices.

Table 7: Kenya Gazette Notices and Nature of Content

S/no	Gazette Notice Number	Date of Publication	Details of the Gazette Notice
1.	Vol. CXXIII- No. 58 Gazette notice no. 2750	15/4/21	Declaration of the person elected as Member of the Senate Machakos County by-election
2.	Vol. CXXIII-No. 54 Gazette notice no. 2608, 2607, 2606	15/4/21	-Appointment of Returning and Deputy Returning Officers for 18/3/21: - Garissa County (Senate) - Bonchari & Juja constituencies - County Assembly Rurii ward- Nyandarua

S/no	Gazette Notice Number	Date of Publication	Details of the Gazette Notice
			County i) Names and symbols for the independent candidates ii) Party primaries for Jubilee party for Juja and Kiambu iii) Party primaries for Rurii ward iv) Party primaries for ODM for Bonchari constituency
3.	Vol. CXXIII-No. 56 Gazette notice no. 2748	15/4/21	Addendum for the 4 th schedule to the party primaries list of aspirants- Nyandarua
4.	Vol. CXXIII- No. 68 Gazette notice no. 3191	15/4/21	Nominated candidates for the Members of National Assembly for Juja and Bonchari constituencies, member of Rurii ward in Nyandarua for 18/5/21
5.	Vol. CXXIII-No. 32 Gazette notice no. 1539, 1540, 1542 1538, 1541, 1544	16/2/21	IEBC notice for nominated candidates, tallying centers, Polling Stations & notice for Machakos County senate by- election & Matungu & Kabuchai constituencies by-elections to be held on 18/3/21 and 4/3/21 respectively
6.	Vol CXXIII- No. 68 Gazette notice no. 3191	8/4/21	Nominated candidates for Members of National Assembly for Bonchari and Juja and for Rurii Ward
7.	Vol. CXXIII No. 66 Gazette notice no. 3189	15/4/21	Declaration of no contest for Garissa senate by- election scheduled to be held on 18/5/21
8.	Vol. CXXI- No. 145 Gazette notice no. 10055, 10054, 10056	30/4/20	Administrative procedures for IEBC for administration of part 5 of Public Officer Ethics Act, 2003
9.	Vol. CXXII- No. 211 Gazette notice no. 10170	30/4/20	Nominated candidates for the Dabaso County Assembly Ward, voter Polling Stations and tallying centers

3.2.7 Electoral Dispute Resolution

The Commission aspires to put in place an effective electoral dispute resolution mechanism as governed by the provisions of Article 88(4), (e) and (j) of the constitution in respect to all pre-election disputes and complaints.

Owing to the challenges experienced in other electoral cycles, the Commission resolved to constitute 3 panels for the resolution of the 2022 nomination disputes as an effort towards ensuring effective and timely resolution of the disputes lodged with the Commission.

Vide Gazette Notice No. 6606 Vol I. CXXIV—No. 105 dated 6th June 2022, the Commission appointed three members to sit in each panel comprising of a Chairperson (Advocate of the High Court of Kenya selected from the Commission's prequalified list of Law Firms), two Members (Commissioners) and a Secretary.

During the period under review, the Commission received complaints and disputes arising from the General Election and by-elections conducted by the Commission in various constituencies and wards as shown in Tables 8.

Table 8: Disputes Heard and Determined

	Allowed	Dismissed	Withdrawn	
Panel 1	19	78	10	107
Panel 2	9	111	2	122
Panel 3	11	80	5	96
TOTAL				325

3.2.8 Investigation and Compliance

During the year under review, the Commission in collaboration with the Ethics and Anti-Corruption Commission (EACC) and other relevant agencies in Compliance with Chapter 6 of the Constitution vetted 21,863 aspirants who intended to participate in the 9th August 2022 General Election. Five aspirants were found non-compliant and were disqualified from participating in the election. Three cases on offences related to violation of the Electoral Code of Conduct and general theft cases were investigated. Annex 2 shows the nature of the case and where the offence was committed. Table 9 shows a summary of the cases investigated on violation of Electoral Code of conduct, compliance with Chapter Six of the Constitution and general investigation.

Table 9: Investigation and compliance with Chapter six of the Constitution

Key output	Performance Indicator	Planned Target 2021/2022	Actual Achievement 2021/2022	Remarks
Compliance with Chapter 6 of the Constitution	Percentage of aspirants vetted by Chapter Six Working Group	100	100	21,863 aspirants were vetted
Informed decision on reported cases	Percentage of cases reported against violation of code of conduct resolved	100	100	3 cases were reported and investigated.
	Percentage of reported cases investigated	100	100	29 cases were reported and successfully investigated.

3.2.9 Leadership and Integrity Vetting Committee and Electoral Code of Conduct Committees

During the period under review, the Commission appointed the Leadership and Integrity Vetting Committee. The committee was tasked with vetting of aspirants for the general election. Additionally, the Commission appointed the Electoral Code of Conduct Enforcement committee to ensure political parties and candidates comply with the Electoral Code of Conduct. Table 10 shows the cases investigated by the committees.

Table 10: Leadership and Integrity Vetting Committee and Electoral Code of conduct cases

S/no	Case number	Parties	Date	Remarks
1	IEBC/LIVC/01/2021	Milton Mwenda & Nathan Gitonga VS Thuranira Salesio Mutuma	24/09/2021	A report was tabled before the Commission Leadership and Integrity Vetting Committee. The case was heard, and a determination

S/no	Case number	Parties	Date	Remarks
				was made to disqualify the two candidates from participating in the By-election.
2	IEBC/ECC/01/2022	Hon. Sabina Chege Vs IEBC	15/02/2022	She was summoned by the Electoral Code of conduct. However, she went to High court for judicial review. An injunction order was issued to bar the Committee from proceeding with the hearing.
3.	IEBC/ECC/01/2022	Hon. Moses Kuria Vs IEBC	30/03/2022	He was summoned by the Electoral Code of conduct. However, he went to High court for judicial review. An injunction order was issued to bar the Committee from proceeding with the hearing.

3.2.10 Internal Investigation

During the year under review, the Commission conducted internal investigation as shown in Table 11.

Table 11: Internal Investigation

Nature of investigation	No. of staff involved	Action taken
<ul style="list-style-type: none"> • Illegal voter transfer • Irregular voter registration 	5	Suspension

3.2.11 Compliance with Chapter six of the Constitution

The Commission in keeping with the prescriptions of Chapter Six of the Constitution on leadership and integrity is obligated to ensure that only persons who meet the educational, moral and ethical requirements are registered and cleared to contest as candidates in election. During the period under review, the Commission collaborated with Ethics and Anti-corruption Commission (EACC) and Commission of University Education (CUE) investigate moral, ethical and educational compliance of candidates. Table 12 presents a summary of cases.

Table 12: Summary of Chapter Six Working Group cases investigated

S/no	Cases	President	Governor	Senate	WMNA	MNA	MCA
1.	Under Investigation	1	10	-	-	-	-
2.	Under Prosecution	1	12	5	1	12	24
3.	Impeached	-	2	1	-	-	-
4.	Public Officers who did not resign by 9 th February, 2022	1	40	-	17	39	69
5.	Convicted	-	1	-	-	2	1
6.	Convicted but pursuing active appeals	-	-	-	-	1	-
7.	Acquitted	-	6	-	-	-	-
8.	Academic Requirements	-	2	-	-	-	-
	TOTAL	3	73	6	18	54	94

The Commission deliberated the report, appraised the Constitutional provisions, statutory and regulatory prescriptions relevant and in addition applicable judicial determinations and resolved as shown in Table 13.

Table 13: Disqualified Aspirants to Contest in the 9th August 2022 General Election

No	Cases	President	Governor	Senate	WMNA	MNA	MCA
	Impeached/ Removed from public office for breach of chapter six of the Constitution.		-Mike Mbuvi Sonko (Mombasa). -Chitavi Antony Mkhala (Mombasa)	-Paul Karungo Thangwa (Kiambu)			
	Academic Requirements: Invalid Degree.		-Thuo Mathenge (Nyeri). -Ekamais Jeremiah Loromukai (Turkana)				
	Convicted of economic crimes offence but not pursuing appeal. In addition, barred by the Court from holding public office.						David Njilithia Mberia (Karen Ward).
	TOTAL	-	2	1	-	-	1

Political Party Regulation

The Constitution of Kenya confers upon the Commission the mandate to regulate the process by which Political Parties nominate candidates for elections and the amount of money spent by candidates and political parties in an election.

The Commission's Directorate of Legal Services is the focal point for liaison with the Office of Registrar of Political Parties (ORPP) and Political Parties. This facilitates the regulation of Political Parties on electoral matters, either directly or through the Registrar of Political Parties and the Political Party Liaison Committee (PPLC). PPLC is the established platform for dialogue between all registered Political Parties, ORPP and the Commission at the National and County levels.

Emerging issues and targeted concerns are addressed through PPLC meetings which are held quarterly. The PPLC currently performs its functions through the National PPLC which comprises six sub-committees namely: Finance; Legal and Dispute Resolution; Internal & External Affairs; Civic, Political Education, & Publicity; Electoral Process; and Audit & Compliance.

Against this backdrop, the National PPLC with the support of the ORPP enables the various Committees to draw work plans. The Commission offers technical support to the various committees based on the Commission's roadmap.

During the year under review, the Commission enhanced collaborative engagements with PPLC to discuss *inter-alia* election-related issues and review of laws governing the regulation of Political Parties in election processes as shown in Table 14.

Table 14: PPLC activities by Commission

No.	Thematic Area	Activities
1.	Electoral reform and review of laws regulating political parties.	3 rd – 6 th February 2021 – Workshop deliberation on the financial implication of implementation of the proposed Political Parties primaries reforms
		9 th -12 th March 2022 – Workshop Discussion on the legal and electoral reforms undertaken by IEBC and ORPP
		17 th - 19 th November 2021-Workshop Discussions on implementation of HCC Petition No. 19 of 2017 Katiba Institute –Vs-IEBC
		17-19 th November 2021-Discussion on the proposed legal reforms: Political Parties Perspective
2.	Enhanced Collaboration	<p>Political Party Liaison (PPLC) Engagements.</p> <ul style="list-style-type: none"> ○ National PPLC Plenary Meeting- 17th – 19th November 2021 ○ National PPLC Consultative Committee Meeting-12th-14th December 2021 ○ National PPLC Plenary Workshop on the policy direction of the 2022 PPLC activities and state of electoral preparedness by all stakeholders - 9th-12th March 2022 ○ National PPLC Plenary Meeting on electoral Timelines, Voters Register and Registration of Candidates - 12th-15th May 2022 ○ 20th May 2022- CRMS Workshop and training on uploading particulars of candidates on the CRMS platform
3.	By-Elections and General Election	Held PPLC meetings and liaised with Political Parties, fielding candidates
		<p>Held consultative meetings through the Political Parties Consultative Forum with participating Political Parties to agree on respective obligations of parties participating in by-elections scheduled on:</p> <ul style="list-style-type: none"> ○ 14th October 2021 -Nguu/Masumba Ward, Kibwezi West Constituency, Makueni County ○ 16th December 2021- Kiagu Ward, Meru County and Mahoo Ward in Taita Taveta County

No.	Thematic Area	Activities
		Received and reviewed party membership lists from Political Parties participating in the by-elections.
		Submission of election officials' details to Political Parties (Regulations 4, 5, & 6 of the Elections (General) Regulations, 2012, fourteen (14) days prior to their appointment to enable parties make their representations). The Commission shared the details of the poll officials for the various by-elections.
4.	Implementation of Election Campaign Financing regulation.	Reviewed the 2020 Draft Election Campaign Financing Regulations. Re-engaged the Parliamentary Committee on delegated Legislation on publication of the Draft Regulations.
5.	Party Nominations and Party List	<ul style="list-style-type: none"> ○ Received and Reviewed Party Nomination Rules from Political Parties intending to Participate in 2022 General Election – 18th October – 16th November 2021 ○ Received and gazetted the list of aspirants of political parties conducting direct party nominations ○ Received and reviewed party membership lists from each of the political parties participating in the 2022 General election. ○ Held PPLC meetings and liaised with political parties fielding candidates in the 2022 General Election ○ Received the list of all political parties' candidates participating in the General Election in liaison with DVREO ○ Reviewed the list of candidates for Members of the National Assembly and Senate submitted by Political Parties for compliance with the two-third gender Rule as directed in HCC Petition No. 19 of 2017 Katiba Institute –Vs-IEBC ○ Received and Reviewed Party lists submitted by political parties for compliance with the constitutional and statutory provisions

Electoral Dispute Resolution

Electoral Dispute Resolution is a critical component in the electoral cycle. Lack of proper judicial and administrative mechanisms established to adjudicate electoral disputes impacts directly upon the extent to which elections are considered free and fair.

The Commission aspires to put in place an effective electoral dispute resolution mechanism as governed by the provisions of Article 88(4), (e) and (j) of the Constitution in respect of the settlement of disputes relating to or arising from nominations and determination of violations of the Electoral Code of Conduct.

During the period under review, the Commission received, heard and determined complaints during the Registration of Candidates for the General Election.

Equity in Representation in Parliament and County Assembly levels

The Constitution of Kenya, 2010 prescribes for the promotion of the representation in Parliament and County Assemblies of women, persons with disabilities, youth, ethnic and other minorities and marginalized communities in the process of nominating candidates for election.

Article 90 of the Constitution of Kenya, 2010 bestows upon the Commission the responsibility to conduct and supervise elections for special seats based on proportional representation by use of party lists. Section 36 of the Elections Act, 2011 consequently, provides that the Commission shall allocate special seats in each of the Assemblies based on the proportional seats a Party obtained in that respective House.

During the year under review, the Commission received Party Lists from a total of seventy-nine (79) out of eighty-three (83) political parties for allocation based on the proportional seats each of the political parties would get in that respective House.

Challenges and Lessons Learnt

In the year under review, the Commission experienced several challenges that had an impact on its processes and service delivery. The Risk Management framework put in place helps identify and proposes mitigating measures for future improvement: Table 15 highlights issues, challenges and lessons learnt.

Table 15: Challenges and Lessons learnt

Issue	Challenge(s)	Lessons Learnt/Recommendations
Electoral Dispute Resolution	<ul style="list-style-type: none"> ▪ Limited capacity of Committee Members. ▪ Insufficient budget to manage sittings 	<ul style="list-style-type: none"> i. Capacity Building of Committee members. ii. Enhanced budget.
Political Party Regulation	<ul style="list-style-type: none"> ▪ Divergent Political Party ideologies. ▪ Indiscipline in Political Party Structures. ▪ Inconsistencies in electoral laws governing political party regulation. ▪ Conflict of laws on the regulation of political parties' nominations ▪ The Court decision that has stripped the Commission's powers to enforce the Electoral Code of Conduct 	<ul style="list-style-type: none"> i. Review of laws governing political party regulation through implementing bodies approach. ii. Enhanced collaboration between Commission, ORPP and political parties ii. Streamlining of the Elections Regulations and Political Parties Act to remove conflict brought by the two legislations on political parties' nomination processes.
Party Lists	<ul style="list-style-type: none"> ▪ Political Party indifferences. ▪ Political deceit by political party leaders on the nomination to the lists ▪ Lack of appreciation of the purpose and intention of the Party list by most of the parties in nomination to the lists ▪ A lot of requests from political parties to amend their lists even after the publication in the Newspapers without a proper justification. 	<ul style="list-style-type: none"> i. Enhanced enforcement of rule of law. ii. Review laws governing party lists ii. Capacity building of political parties and other stakeholders to understand and appreciate the purpose of the party list.
Legal Reforms	<ul style="list-style-type: none"> ▪ Delay in passage of Electoral Laws by Parliament ▪ Rejection of the Elections Campaign Financing Regulations, 2020 made it hard to implement the Principal Act 	<ul style="list-style-type: none"> i. Request the Speaker of the incoming 13th Parliament to fast-track deliberations on the Electoral Laws once presented to Parliament.

In order for the Commission to strengthen the legal framework to enable it to exercise its powers and perform its functions. Table 16 presents Commission's performance in relation to political party regulation.

Table 16: PPLC Political Parties Regulation

Performance Indicator	Planned Target 2021/22	Actual Achievement 2021/2022	Remarks
% of Political Parties compliant	100% of all registered political parties compliant.	90% compliant in the General election	Commission enhanced regulation and collaboration with the PPLC in rallying political players to maintain peace and adhere to the laws during the nomination and campaign period.
Number of disputes heard and determined.	100% of complaints filed and adjudicated through the Dispute Resolution Committee (DRC) effectively concluded within timelines set by law.	At least 90% of the decisions by the IEBC Dispute Resolution Committee were accepted by the complainants.	Commission heard 323 complaints arising from the registration of candidates for the General Election and four (4) from Party List disputes.
% of Political Parties compliant	100% of all registered political parties compliant.	90% of the Parties fully complied with Guidelines issues	Parties unable to recruit sufficient SIG members Reluctance by males to appear in the Gender Top-Up lists.

3.3 Key Result Area#3: Effective Conduct of Elections

The Commission is responsible for managing electoral processes which include Voter registration, Electoral operations and logistics, electoral training and coordination of field services. This entails a series of inter-related pre, during and post-election activities geared towards attainment of free, fair and credible elections. During the period under review, the Commission's achievement is shown in Table 17.

Table 17: Effective conduct of Elections

Key Output	Performance Indicator	Planned Target 2021/2022	Actual Achievement 2021/2022	Remarks
Elections Conducted	Number of by-elections conducted	4	9	1 MNA 5 MCA's 1 Red cross 1 Law Society of Kenya 1 Judiciary
	Number of candidates registered for General election	14,552	16,105	Increased interest in elective positions
	Number of new Polling Stations mapped	12417	5346	Voter apathy
	Number of new Diaspora Polling Stations	6	27	More than 1 consulate in some countries Number of registered voters exceeding the capped 700 in a single station in some consulates

Key Output	Performance Indicator	Planned Target 2021/2022	Actual Achievement 2021/2022	Remarks
	Number of Chief Agents trained for Elections	37	37	The agents were trained for By-elections
	Number of Electoral Training Manuals reviewed	4	18	See Annex 6 for the list of training manuals reviewed.
	Percentage of Polling Stations accessible by PWDs and other special needs groups	100	90	Conducted mapping of 46,229 Polling Stations and 90% of the polling complied.
Register of Voters	Number of new Voters Registered	6,000,000	3,030,810	Voter apathy
	Number of voters who verified their details in the Register	2,743,498	5,334,483	3,280,930- Walk-in verification 1,747,843- SMS 305,710- Web verification Voter apathy
	Audit of the Register of voters report	1	1	Implemented the short term recommendations from the Audit firm. Correction of exemptions in the ROV
	Certification of the Register of Voters	1	1	Certified Register of voters in respect to every electoral area.

Voter Registration

The Commission is legally required to establish a comprehensive, accurate and complete register of voters that confers legitimacy of the entire electoral process.

Electoral Operations and Logistics

Electoral operations are key aspects in the conduct of elections and related logistical requirements. It determines efficient and effective conduct of electoral activities such as the management of electoral materials and logistics.

Electoral Training

Electoral training is an integral part of the electoral processes, and the Commission heavily invests in electoral training as a way of ensuring effective and efficient electoral processes. Through training, personnel have been prepared for elections, registration of voters, inspection and verification of the register, nomination of the candidates for elections among other electoral activities.

In preparation for the forthcoming General Election, the Commission conducted cascaded training for its poll officials. The training was implemented in six different levels as shown in Table 18:

Table 18: Cascaded Training for Poll Officials

LEVEL	ACTIVITY	DAYS	CADRE	NUMBER
Level One (National)	Content Development by Master Trainers	4	Mater Trainers	30
Level Two (National)	Induction of Trainer of Trainers	4	Mater Trainers & ToTs	150
Level Three (Cluster)	Cluster based Training for General Elections officials	4	CROs, DCROs, Ros, DROs, Accountants, CICTOs & SCMA's	1105
Level Four (County)	Training of SETs, Logistics Officers and ICT Clerks	4	SETs, Logistics Officers & ICT Clerks	6628
Level Five (Constituency)	Training of POs & DPOs	4	POs & DPOs	94873
Level Six (Constituency Ward)	Training of Polling/Counting Clerks	2	Polling Clerks	325323

The Commission in preparation for the 2022 General Election recruited and trained a total of 418,192 personnel as illustrated in the Table 19:

Table 19: Election officials

No	Election Officials	Posts
1	Deputy County Returning Officers	47
2	Deputy Constituency Returning Officers	290
3	Presiding Officers	52,481
4	Deputy Presiding Officers	52,481
5	Logistics Officers	389
6	Support Electoral Trainers (SETs)	5,827
7	ICT Clerks	580
8	Polling Clerks/Counting Clerks	302,860
9	County-Based Voter Educators	47
10	Constituency-Based Voter Educators	290
11	Ward-Based Voter Educators-2 per CAW	2,900
12	Temporary Warehouse Assistants	100
13	Media and Call center Assistants	150
	Total	418,442

Conduct of by-elections

During the period under review, the Commission conducted by-elections for one Member of National Assembly and five Member of County Assembly. Table 20 show the breakdown.

Table 20: By-elections conducted

COUNTY CODE	COUNTY NAME	CONSTIT. CODE	CONSTIT. NAME	CAW CODE	COUNTY ASSEMBLY WARD NAME	SURNAME	OTHER NAMES	POLITICAL PARTY/ INDEPENDENT	VOTES GARNERED	DATE OF BY-ELECTION
022	Kiambu	118	Kiambaa			Wanjiku	John Njuguna	United Democratic Alliance	21,773	15th July 2021
008	Wajir	037	Eldas	0180	Eldas	Abdulahi	Abdi Abass	Jubilee	Un Opposed	15th July 2021
022	Kiambu	119	Kabete	0592	Muguga	Mun'gara	Joseph Githinji	Jubilee	4089	15th July 2021
017	MAKUENI	087	KIBWEZI WEST	0435	NGUU/M ASUMBA	MANENO	THIMOTY SIREI	IND	2902	14 th October 2021
012	Meru	058	Central Imenti	0288	Kiagu	Ngaruni	Simon Kiambi	United Democratic Alliance	2440	16 th December 2021
006	Taita Taveta	023	Taveta	0112	Mahoo	Saleri	Donald Fundii	Jubilee	1609	16 th December 2021

Other key activities.

The Commission conducted the following key activities;

- i) Three National Elections for LSK male (representative to JSC and Supreme Court representative) and Kenya Red Cross Society
- ii) Training of Registration Personnel for Enhanced Continuous Voter Registration (ECVR 1&II) Trained on Registration, Candidate Registration, trained Media, judiciary and Law Society of Kenya (LSK) on their role in electoral process
- iii) Submission of the constitutional amendment bill to 47 county Assemblies
- iv) Mapped to establish status of previously gazetted registration centres as well as proposed new registration centres which resulted in increased from 24613 to 27397
- v) Enhanced Continuous Voter Registration (ECVR) I and II that resulted to registration of 2743, 498 new voters and 1068,444 transfer of registration.
- vi) Deployment of technology in administrative management and reporting during ECVR drive and verification.
- vii) Successful migration of Voter registration data from the Biometric Voter Registration in Oti Morpho to Automated Biometric Identity system
- viii) Quality assurance of the register of voters to address the gaps in the register of voters.
- ix) Enhanced targeted registration of new voters in institution of higher learning, correction facilities and in Diaspora.
- x) Biometric verification and inspection of the register of voters. By the end of the exercise a total of 3,280,930- Walk-in verification, 1,747,843- SMS 305, 710- Web verification was achieved.
- xi) Audit of the register of voters in line with Section 8(a) of the Elections Act, 2011. The Commission was able to successfully implement the short-term recommendations.
- xii) Reviewed and developed 20 manuals for use in the 2022 General election.
- xiii) Received and processed Party membership lists from 83 Political Parties.
- xiv) Received and processed symbols and details of Independent Candidates.
- xv) Successfully registered 16,105 candidates for the general election.

xvi) Centralized Kenya Integrated Electronic Management system (KIEMS) and maintenance and warehousing



A Youth registers as a voter during during the launch of Enhanced Voter Registration Exercise (ECVR) in Institutions of Higher Learning.

Review of Manuals

The Commission reviewed and published 21 manuals in preparation for the 2022 General Election. These included:

Table 21: Review and development of manuals

REVIEWED	DEVELOPED
1. Polling Station Diary	1. Presiding Officer's Quick guide
2. Elections Result Management Framework	2. CRO Quick guide
3. Facilitator's Manual	3. RO Quick guide
4. Framework for Candidate Registration Management System	4. Tallying Centre guide
	5. Nomination & registration Manual

REVIEWED	DEVELOPED
	6. Elections Agent's Manual
	7. Election Communication Centre guide
	8. Electoral Training Policy
	9. Elections Training Curriculum
	10. Conduct of External Election guide
	11. Elections handbook
	12. Post-Elections guide
	13. Election compendium

3.4 Key Result Area#4: Public Outreach

The Commission engages stakeholders and partners in electoral processes; designs, develops and disseminates voter education information to enhance public participation, and instill public confidence throughout the electoral cycle.

Cognizant of the need to tell its own story, the Commission has progressively improved internal and external strategic communications, coordination of corporate events, and corporate reputation management. Moreover, the commission has endeavored to give back to the communities through corporate social responsibility activities to improve brand visibility and strengthen existing relationships. Concomitantly, it gives the public the opportunity to relate and engage with the Commission activities.

To achieve this, the Commission conducted stakeholder forums, entered strategic partnerships, voter education activities, disseminated voter education messages using radio presenter mentions, brochures, posters and radio talk shows. This was aimed at informing and encouraging voters to participate in electoral processes.

Table 22 highlights the key achievements for the year under review.

Table 22: Effective conduct of elections

Key Output	Performance Indicator	Planned Target 2021/2022	Actual Achievement 2021/2022	Remarks
Increased Public Awareness on Electoral Processes	Number of Voter Education Providers accredited	52	111	Increased public interest in participation in the electoral processes
	Number of Voter Education Materials developed	12	25	<ul style="list-style-type: none"> Additional funding from stakeholders Increased number of electoral activities 9 Fliers 3 Stickers 9 Posters 3 booklets (FAQs, Induction of Voter Educators' Manual, Observer Guidelines) 1 Braille book

Key Output	Performance Indicator	Planned Target 2021/2022	Actual Achievement 2021/2022	Remarks
	Number of Voter Educators engaged	6,474	9,734	6 By-elections ECVR I & II Voter Verification
Media Monitoring and Analysis	Number of reports generated	417	417	Conducted daily and Weekly social media monitoring and analysis Critical information from which the Commission drew insights and content for media interviews, press releases, press briefings, opinion editorials, frequently asked questions, infographics, which addressed the issues raised in a timely manner
Collaboration with media in the delivery of Commission mandate	Number of Media Engagements	6	44	Engaged with Media Council of Kenya (MCK), Kenya Editors Guild (KEG) and Kenya Union of Journalists (KUJ), Foreign Correspondents' Association of East Africa, Correspondents Association of Kenya, Bloggers Association of Kenya, Radio Africa Group and held press conferences.
	Number of journalists trained	300	635	Increased interest in coverage of electoral activities
Dissemination of voter information	Number of Website updates	117	275	Updated various pages on the website as follows: press releases (80), news (27), Gazette Notices (53), tenders (102) and speeches (13).
	Number of Social media updates	468	<ul style="list-style-type: none"> • Facebook: 798 posts • Instagram: 308 posts • Twitter 1,231 posts • YouTube: 23 posts • Facebook live sessions. 	<ol style="list-style-type: none"> 1. 12,724,334 Facebook impressions and 181,416 engagements 2. 197,194 Twitter impressions and 9,784 engagements 3. 13,788,460 impressions and 1,383,049 engagements 4. 3,494 YouTube subscribers 5. 18,604 Facebook live sessions views and 6,585 impressions
	Number of Media personnel accredited	500	160	Conducted only 6 By-elections compared to 18 By-elections in the previous year.
	Number of Media Campaigns and Mainstream media live broadcasts	19	151	Conducted live broadcasts for ECVR I and ECVR II, Voter verification and Audit of Register of Voters
	Number of Ballot	56	49	90% done

Key Output	Performance Indicator	Planned Target 2021/2022	Actual Achievement 2021/2022	Remarks
	Newsletter and e-bulletins produced			48 e-bulletin have been produced and One edition of the Ballot Newsletter - Edition 12
	Number of bulk SMS sent	56,000	65,122	Bulk SMS system for both internal and external notices
Brand recognition	Number of events branded	4	156	Increased number of electoral activities towards the General Election.
	Production of promotional materials	8	8	100% done the Commission printed the following corporate merchandise diaries, shirts, blouses, branded notebooks, staff badges, calendars, business cards
	Number of exhibitions the Commission participated in	1	2	Devolution Conference, 10th anniversary of the Constitution Commissions and Independent Offices
	Number of enquiries responded to at the Customer care desk	1,154	6,500	Walkins – 1,500 Emails – 2,000 Calls – 3,000
Continuous stakeholder engagement	Number of stakeholder forums held	202	3,144	Increased electoral activities. 3 per county 3 per constituency 1 per diaspora station for each activity (ECVR I&II and RoVV) 27 nationally 30 forums for by-election
	Number of forums for SIGs	94	1,011	1 per county for each activity 1 per constituency for each activity (ECVR I&II and RoVV)
	Number of MoUs signed	2	20	Increased number of electoral activities towards the General Election.
	Number of observers Accredited	2,069	15,226	(69 observers for 6 by-elections 15,157- Long Term Observers)

Stakeholder Engagement

The Commission appreciates the support provided by stakeholders and partners in implementing its programs and activities. During the period under review, the Commission engaged with stakeholders in the conduct of by-elections, ECVR I & II, development of electoral materials and capacity building of staff.



A Voter Educator engages the public at Gachie Market during the July 15th, 2021 by-elections.



Voter registration at the 7th (and final) Annual Devolution Conference, 2021 in Makueni County.

3.5 Key Result Areas#5: Equitable Representation

The Constitution of Kenya; Article 89, provides for the review of names and boundaries of constituencies and wards at intervals of not less than eight years, and not more than twelve years, and a Review must be completed at least twelve months before a General Election of members of parliament. The First Review under Constitution of Kenya, 2010 was undertaken in 2012, thus, the Second Review of boundaries will be completed by 2024.

During the period under review, in preparation for the Electoral Boundaries' Delimitation the Commission undertook the following activities.

a) Boundaries Delimitation

The Commission embarked on updating of sub-location base data in collaboration with the Ministry of Interior and Survey of Kenya. It involved updating of the boundaries of existing Sub locations in order to align it with the electoral boundaries and ensure accurate geo-database in preparation for the upcoming boundary delimitation.

The update of the Sub Location was undertaken in 38 Counties namely; Machakos, Embu, Mombasa, Kwale, Taita-Taveta, Kilifi, Lamu, Tana River, Kitui, Makueni, Nakuru, Kajiado, Kisii, Murang'a, Narok, Kiambu, Kirinyaga, Meru, Isiolo, Laikipia, Baringo, Samburu, Tharaka Nithi, Nyeri, Nyandarua, Kericho, Bungoma, Kakamega, Uasin Gishu, Nandi, Busia, Siaya, Migori, Nyamira, Elgeyo Marakwet, West Pokot, Homabay and Kisumu.

The exercise revealed 1,864 additional Gazzetted and operationalized sub-locations since 2012 as shown in Table 23.

Table 23: The number of current sub-locations in the 38 counties completed

2012 Sub-Locations	2021 Sub-Locations	Additional Sub-Locations
5,605	7,469	1,864

The remaining nine (9); Bomet, Garissa, Wajir, Mandera, Marsabit, Nairobi, Trans Nzoia, Turkana and Vihiga County will be completed in the next financial year. Figure 5 shows the status of sub-location data collection by county.

Figure 5: Current status of sub-locations boundary data collection by county

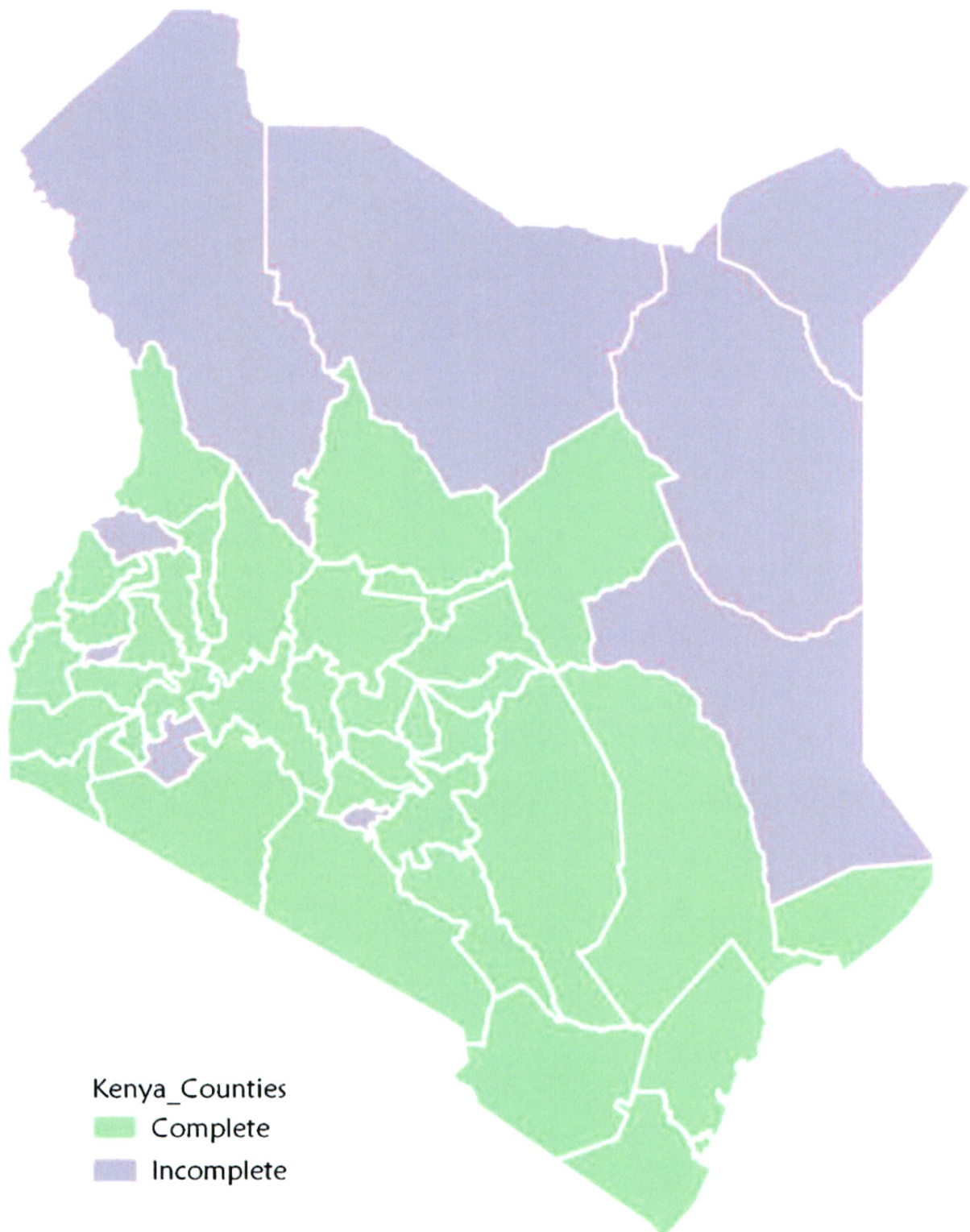

b) Registration Centres GPS Co-ordinates

Registration centres GPS coordinates are physical locations points of facilities such as schools, markets and health centres. A registration centre is Gazetted under a County, Constituency and County Assembly Ward. The physical positioning and allocation of registration centres are of

utmost importance in the electoral process as they enable the voter access registration and voting at the nearest facility to exercise their democratic rights. It also informs planning, logistics and result transmission for the General Election.

Consequently, in preparation for the 2022 General Elections, the Commission reviewed and captured the GPS coordinates of the Gazzeted Registration Centres. During the year under review the Department undertook the activities in the Table 24.

Table 24: Equity in Representation

Key Output	Performance Indicator	Planned Target 2021/2022	Actual Achievement 2021/2022	Remarks
Equitable Representation	Number of updated counties' boundary data	47	38	9 Counties to be concluded in the Financial Year 2022/23
	Number of GPS coordinates collected for the gazette registration centers	5,346	5,346	Registration centers Annexed.
	Percentage of maps processed	100	100	County Constituency Ward Special maps
	Number of staff trained on emerging electoral boundary technologies	15	15	Continuous training

3.6 Key Result Area #6: Strengthening Strategic Operations

Strengthening Strategic Operations underpins the need to enhance human resource capacity, strengthen corporate governance, re-engineer business processes, secure a conducive work environment, strategic supply chain needs, and institutionalize learning and knowledge-based decision making for a sustainable financial resource base. This section covers six focus areas as listed below;

- i) Finance management,
- ii) Supply chain management,
- iii) Electoral systems and infrastructure,
- iv) Human resources and administration,
- v) Research and development and
- vi) Risk management.

3.6.1 Focus Area #1: Supply Chain Management

The identification of Commission's procurable needs is vital in planning and implementation of its programmes and activities throughout the electoral cycle. This ensures streamlining of the procurement processes, logistics, warehousing and disposal in the day-to-day operations of the Commission. During the year under review, the Commission accomplished the following as shown in Table 25.

Table 25: Supply Chain Management Activities

Key output	Performance indicators	Planned Targets	Achieved Targets	Remarks
Compliance with PPADA	Number of Procurement plans prepared	11	11	Directorates prepared and implemented their Procurement plans. Submitted Consolidated Plan to the National Treasury and PPRA
	Percentage Implementation of the Consolidated Procurement plan	100%	100%	Some procurements were litigated. However, the Commission was able to successfully defend and achieve the targeted outcome.
Disposal of Obsolete stores	Percentage disposal of obsolete stores	100%	98%	During auctioneering some of the goods were not bid for. Disposal to be concluded next financial year
Distribution of General Election Materials	Number of counties distributed with Strategic and Non-strategic Materials	47	47	The Strategic partnership with Postal corporation of Kenya ensured successful delivery of procured election materials.

3.6.2 Focus Area #2 Financial Management

Financing of the Commission’s activities enables it to deliver on its mandate by ensuring adequate budgetary allocation and prudent management of resources. During the year under review, the following were accomplished: -

Table 26: Finance Management

Key output	Performance indicators	Planned Targets	Achieved Targets	Remarks
Compliance with PFM, IPSAS, IFRS and Policies	Number of Financial Statements prepared	5	5	4 quarterly reports and Consolidated Financial statements Prepared and submitted
Commission Work plan	Percentage of Budget Execution	100	84.78	Savings arose from competitive procurement of Goods and services and low turnout during voter registration
	Number of work plans prepared	18	18	Directorates prepared and implemented their Normal and GE work plans

3.6.3 Focus Area #3 Electoral Systems and Infrastructure Sustainability

The Commission has incorporated the use of technology in its processes to enhance efficiency towards service delivery. This has enhanced the Commission’s capacity in provision of electoral technology advisory, development and implementation of ICT policies and procedures, management of election technology and infrastructure.

In the year under review, the following were accomplished.

Table 27: Electoral Systems and Infrastructure Sustainability

Key Output	Performance Indicator	Planned Target 2021/2022	Achieved Targets 2021/2022	Remarks
ICT infrastructure scaling and optimization	Percentage completion on the renovation of the centralized KIEMS warehouse.	100	90	Implementation of remaining components is ongoing.
	Number of county offices connected to the wide area network (WAN) infrastructure	30	30	Extension of wide area network infrastructure (WAN) to 30 county offices improved communication.
	Percentage upgrade of the ICT security infrastructure	100	100	Upgrade of the ICT security infrastructure has improved confidentiality, integrity and availability of technology.

Key Output	Performance Indicator	Planned Target 2021/2022	Achieved Targets 2021/2022	Remarks
	Percentage upgrade of the BVR infrastructure	100	100	BVR infrastructure upgraded for integration with KIEMS.
	Number of KIEMS kits purchased	14,100	14,100	To cater for additional Polling Stations and replacement of faulty kits.
	Number of computers purchased	250	160	Global shortages.
	Number of multifunctional printers purchased	224	224	Printers to facilitate effective operations.
	Percentage of incidences resolved	100	100	Timely response to all incidences that were reported was realized both at the counties and at the headquarters.
	Number of KIEMS kits configured, tested and deployed	57,000	55,100	Kits for training, spares and for GE.
	Percentage of voters electronically identified	100	99	Poor quality of fingerprints.
Audit of Election Technology	No of reports for certification of election technology.	10	10	In compliance with the election technology regulations
Simulation of Election Technology	Percentage success in RTS simulation one	100	86	Global shortages in microchips for making SIM Cards Lack of 3G network
Automation of Internal Systems and applications	Percentage modification, integration and upgrade of the EVI, EVV, RTS KIEMS modules.	100	100	Complete integration of KIEMS modules
	Number of tools developed for election technology	4	4	Registration centre mapping tool used to populate information on registration centres. ECVR and EVV reporting tool for providing daily updates of the exercise. Online application for confirming registration status of voters

Key Output	Performance Indicator	Planned Target 2021/2022	Achieved Targets 2021/2022	Remarks
				(verify.iebc.or.ke). Participants registration tool for the National Election Conference.
	Number of Systems developed	1	1	Accreditation Management System for registration of observers, voter education providers and media.
Capacity Building in ICT Applications and Systems	Number of trained staff on election technology	700	700	Trained over 700 officials on KIEMS and other election technologies.
	Number of trained staff on legal case management system	33	33	Staff from Directorate of Legal Services trained
	Number of external stakeholders trained	70	70	Trained lawyers, judges, supreme court officials, and political parties on election technology

3.6.4 Focus Area #4: Human Resource Management and Administration

The Commission is committed to attracting, developing and retaining highly skilled, motivated professionals of integrity to implement its mandate. In the financial year under review, the Commission ensured adequate staffing and provided a conducive work environment for enhanced service delivery. As a result, it realized significant milestones in various areas as outlined hereunder.

Table 28: Human Resource and Administration

Key Output	Performance Indicator	Planned Target 2021/2022	Actual Achievement 2021/2022	Remarks
Enhanced efficiency and capacity built	Number of staff recruited	41	7	<ul style="list-style-type: none"> • Commission Secretary/CEO • Deputy Commission Secretary (2) • Director ICT • Director Legal and Public Affairs • Director Research, Boundaries and Development • 34 positions pending

Key Output	Performance Indicator	Planned Target 2021/2022	Actual Achievement 2021/2022	Remarks
				recruitment due to shift of focus to preparation of 2022 General Elections;
	Percentage of staff appraised on their performance	100	100	All the staff both in HQ and field
	Number of staff trained	450	147	Staff trained in a field relevant to their work and professional body annual subscription fee paid. Inadequate funds.
	Number of newly appointed Commissioners and staff inducted	92	92	88 - Staff 4 - Commissioners
	Number of Poll-officials recruited	479,700	423,781	Low voter turnout during registration
	Number of students on attachment and internship	40	26	22 - Attachment 4 - Internship
	Number of staff who complied with Declaration of Income Assets and Liabilities	902	900	Two resigned before submission.
	Number of staff transferred	674	674	Field staff transferred for the General Elections
Conducive work environment and a healthy workforce	Number of Infrastructure and Facilities Developed	5	5	Construction of County warehouses ongoing.

3.6.4 .1 Staffing and Recruitment

As at 30th June 2022, the Commission's Approved Staff Establishment was 1,145 posts with an in-post of 902 and a variance 241.

During the period, the Commission conducted recruitment to fill critical vacancies in its establishment:

- i) Declared vacant and advertised 41 vacant posts for filling.

ii) Conducted interviews and made seven appointments as summarized:

- a. New Appointments - 5
- b. Promotion (serving Staff) - 2
- c. Re-designation - 0

The status of Commission advertised posts is as highlighted hereunder. Due to preparation of 2022 General Elections the interviews for all pending positions were deferred.

iii) In addition, three staff serving on contract were absorbed on permanent establishments after suitability interviews and their terms of employment translated to permanent and pensionable.

Table 29: Commission Vacancies declared and Advertised in the period 2021/2022

No	Job Title/Designation	Grade	Posts	Status as at June 2022
1	Commission Secretary/CEO	1	1	Filled
2	Deputy Commission Secretary (Operations & Support)	2	2	Filled
3	Director Information Communication & Technology	3	1	Filled
4	Director Research, Boundaries and Development	3	1	Filled
5	Director Legal and Public Affairs	3	1	Filled
6	Director, Voter Registration and Operations	3	1	Filled
7	Manager - Finance	3	1	Pending
8	Manager - Risk Management	4	1	Pending
9	Manager -Strategy and Innovation	4	1	Pending
10	County Election Manager - HomaBay	4	1	Pending
11	County Election Manager - Busia	4	1	Pending
12	County Election Manager - Nairobi	4	1	Pending
13	Senior Election Officer - Muhoroni	5	1	Pending
14	Senior Election Officer - Buuri	5	1	Pending
15	Senior Election Officer - Kilifi North	5	1	Pending
16	Senior Election Officer - Gichugu	5	1	Pending
17	Senior Election Officer - Kuresoi South	5	1	Pending
18	Senior Election Officer - Kajiado Central	5	1	Pending
19	Senior Election Officer - Lamu West	5	1	Pending
20	Senior Election Officer - Teso South	5	1	Pending
21	Senior Election Officer - Kiminini	5	1	Pending
22	Senior Election Officer - Mandera West	5	1	Pending
23	Senior Election Officer - Turkana West	5	1	Pending
24	Senior Election Officer - Ijara	5	1	Pending
25	Senior Election Officer - Keiyo North	5	1	Pending
26	Senior Election Officer - Kitutu Chache North	5	1	Pending
27	Senior Election Officer - Narok North	5	1	Pending
28	Senior Election Officer - Kwanza	5	1	Pending
29	Senior Election Officer - Kamukunji	5	1	Pending
30	Assistant Election Officer - Dagoretti South	8	1	Pending
31	Assistant Election Officer - Tiaty	8	1	Pending
32	Assistant Election Officer - Tigania East	8	1	Pending
33	Assistant Election Officer - Kirinyaga Central	8	1	Pending
34	Assistant Election Officer - Kisumu Central	8	1	Pending
35	County Accountant - Turkana	6	1	Pending
36	Accountant	6	1	Pending
37	Accounts Assistant	8	1	Pending
38	County Supply Chain Mgt Assistant - Nyeri	8	1	Pending
39	Records Management Assistant	8	1	Pending
40	Senior Office Administrator	6	1	Pending
	Grand Total		41	

3.6.4.2 Staff Turnover

In the period under review, the staff turnover was at 22 occasioned by retirement, resignation, death, expiry of contract, expiry of secondment and early retirement as shown in in Table 30.

Table 30: Staff Turnover

Sno	Reason for Exit	No of Staff
1.	Contract Expiry	5
2.	Death	4
3.	Expiry of Secondment	1
4.	Resignation	5
5.	Mandatory Retirement	4
6.	Retirement under the 50 yr rule	3
	Total	22

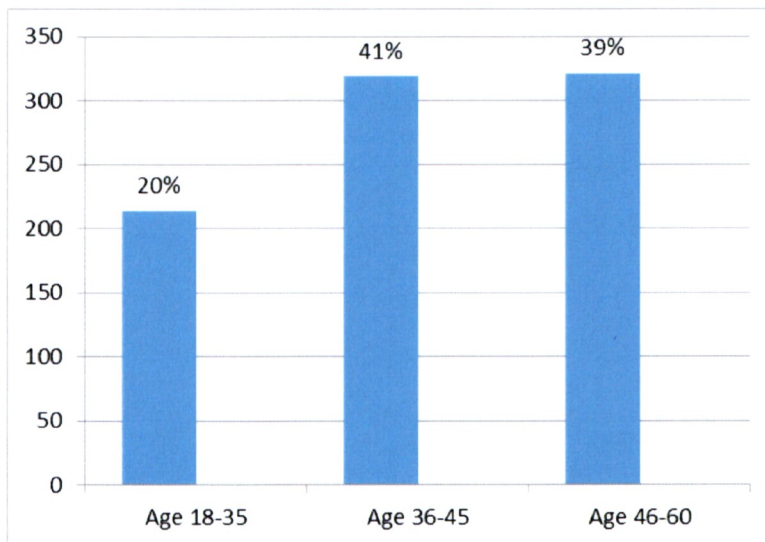

Figure 6: Distribution of staff within the Commission

A detailed analysis of the age structure of the staff as shown in figure 5 indicates that 20% of the staff fall between age group 18-35years, 41% are between 36 - 45 years while 39% are above 45 years.

3.6.4.3 Disaggregation of Staff by Gender

The Commission disaggregated staff profile shows that 64% (576) of the staff are male and 36% (326) are female. The Commission has strived itself in maintaining the gender balance across all levels.

Table 31: Disaggregation of Staff by Gender

GRADE	FEMALE	MALE	GRAND TOTAL	CATEGORY
1		1	1	Senior Management
2	1	1	2	
3	1	5	6	Management
4	23	42	65	

5	85	212	297	Officers
6	45	86	131	
7	4	2	6	Assistant Officers
8	162	169	331	
9	0	34	34	Support Staff
10	5	24	29	
Grand Total	326	576	902	

3.6.4.4 Provision of Conducive work environment

The Commission coordinated office refurbishments and maintenance services at the Headquarters, field offices and the warehouses to provide conducive working environment. Table 32 shows the status of construction works of warehouses.

Table 32: Status report of County Warehouse Construction August 2022

S/No	Project Name	Contract Sum	Project appraisal Variation	Status
1.	Construction of County Multipurpose Warehouses – Kakamega	40,000,000	-	On going
2.	Construction of County Multipurpose Warehouses –Isiolo	37,106,200	2,893,800	On going
3.	Construction of County Multipurpose Warehouses – Machakos	35,843,260	4,156,740	On going
4.	Construction of County Multipurpose Warehouses n – Wajir	40,000,000	10,000,000	On going
5.	Construction of County Multipurpose Warehouses – Garissa	40,000,000	10,229,822	On going

3.6.5 Focus Area 5 # Research and Development

The Commission relies on research and innovation as a critical component to inform its institutional transformation and management. These guides in the development of accountability measures, enhancement of strategic planning and monitoring of the performance indicators.

In addition, research plays an important role in providing evidence-based knowledge for informed decision-making and policy formulation as well as archiving and storing of essential information materials used in elections.

During the year under review, the Commission conducted research on thematic electoral areas and serviced data requests as shown in Table 33.

Table 33: Research and Strategy

Key Output	Performance Indicator	Planned Targets	Achieved Targets	Remarks
Data and Information Provided	Percentage of requests serviced	100	100	
Informed Decision-Making on Electoral Processes	Number of research reports on thematic Electoral Areas	4	4	
	Monitoring and Evaluation Framework Developed	1	1	
	Number of monitoring and evaluation reports on electoral activities	6	9	Monitored ECVRI&II, Voter Verification and By-Elections

3.6.5.1 Development of the Monitoring and Evaluation Framework

During the year under review, the Commission in collaboration with the International Foundation for Electoral Systems (IFES) conducted a workshop to train M& E champions composed of staff from both HQ and Counties.

The training was aimed to enhanced knowledge on Monitoring and Evaluation which, subsequently, shall be used to implement the Monitoring and Evaluation Framework.



Monitoring and Evaluation (M&E) Champions

3.6.5.2 Research Studies on Thematic Electoral Issues

The Commission conducted research on;

- i. The main causes of rejection of ballots, the case of 2017 General Elections
- ii. Use of Research to enhance Voter Registration
- iii. Staff Satisfaction Survey on IEBC Medical Scheme

3.6.6 Focus Area 6 # Electoral Risk Management

Risk identification and management is a key pillar of corporate governance. Every electoral process and support service has inherent risk factors, which ought to be strategically addressed. To comply with the provisions of Article 81 on general principles for the electoral system, the Commission has continued to institutionalize risk management in its operations. The purpose of integrating risk management in IEBC is to identify the risk factors and develop mitigation strategies that would assist the Commission fulfill its mandate. Table 34 shows the risk management activities for the year under review.

Table 34: Risk management

Key Output	Performance Indicator	Planned Targets	Achieved Targets	Remarks
Risk Management Strengthened	Number of staff trained in Enterprise-wide risk management	56	56	Staff trained both in HQ and field
	Number of risk assessment and monitoring reports prepared and disseminated	9	9	Risk assessments of ECVR1&II, Voter Verification and By-Elections
	Number of times the Risk Register is updated	4	4	Updated quarterly
Coordinated response to election security threats	Number of ESAP Materials developed	3	3	<ul style="list-style-type: none"> • Security Guide • ESAP Training Manual • Handbook on Election Security
	Number of IEBC officials trained on ESAP	1,000	2,376	Donor Support enabled the over-achievement IEBC staff, Judicial officers and Law-enforcement officers trained.
	Number of election officials trained on ESAP	130,000	150,000	Master Trainers – 50 National ToTs – 150 Regional ToTs – 300 County trainings – 570 Constituency and sub-county – 148,930

3.6.6.1 Risk Management Governance

The Commission has put in place Risk Management structure at all levels as indicated in the Table 35.

Table 35: Risk management Structure

	Structure in the Risk Management Framework	Equivalent Structure in the Commission
1.	Board Risk Committee	Plenary/ Commissioners
2.	Audit and Risk Committee	Audit and Risk Committee
3.	Risk Management Committee	Commission Management
4.	Risk Owners	Directors and CEMs
5.	Staff	All cadres of staff

The Audit and Risk committee is chaired by an external person appointed from outside the Commission. All the other committees are chaired internally by Commissioners. This is inline with best corporate management practices.

3.6.6.2 Electoral Security Arrangement Program

Electoral Security Arrangement Program (ESAP) is a collaborative engagement that harnesses the efforts of institutions within the Administration of Justice sector to build synergy in the management of Election Security. The purpose of ESAP is to give an assurance of security during the entire electoral cycle which is essential in inspiring the confidence and commitment of all stakeholders and participants in the electoral process. ESAP is also geared towards efficient and proper enforcement of the Elections Offences Act, 2016.

The institutions collaborating in ESAP include the Judiciary, the National Police Service (NPS), the Office of the Director of Public Prosecutions (ODPP), the Office of the Registrar of Political Parties (ORPP), the Independent Policing Oversight Authority (IPOA), the National Cohesion and Integration Commission (NCIC), the National Steering Committee on Peace building and Conflict Management (NSC) and Civil Society groups.

Section 4: Financial Statements

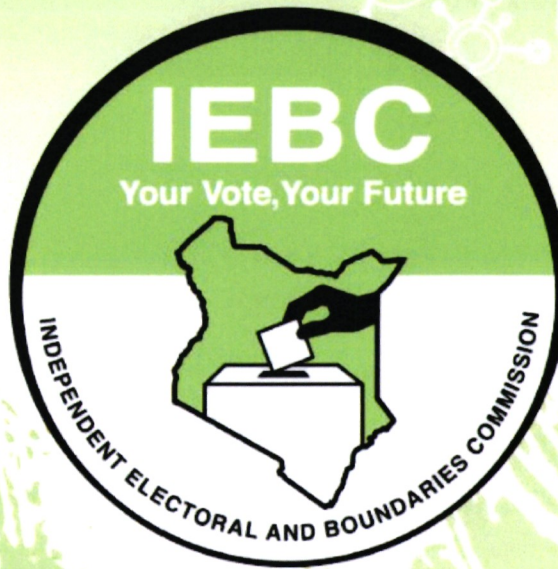

**ANNUAL
REPORT**
2021/2022



INDEPENDENT ELECTORAL AND BOUNDARIES COMMISSION

ANNUAL REPORT & FINANCIAL STATEMENTS

FOR THE YEAR ENDED

30TH JUNE 2022

Prepared in accordance with the Accrual Basis of Accounting Method under the International Public Sector Accounting Standards (IPSAS)

KEY COMMISSION INFORMATION AND MANAGEMENT

1. Background information

The Independent Electoral and Boundaries Commission is a Constitutional body established under Article 88 of the Constitution of Kenya and is a body corporate pursuant to Article 253 of the Constitution of Kenya. As per Article 88 of the Constitution of Kenya 2010, the Commission is responsible for conducting or supervising referenda and elections to any elective body or office established by the constitution, and any other elections as prescribed by an Act of Parliament. Article 88 and IEBC Act 2011 further enumerate the mandate of the Commission to include, inter alia, continuous registration of voters, revision of the voter's roll; delimitation of constituencies and wards boundaries; regulation of political parties process; development of a code of conduct for candidates and parties and monitoring of compliance with legislation on nomination of candidates by parties.

2. General Information

The Independent Electoral and Boundaries Commission is established under Article 88 of the Constitution of Kenya, 2010 and is a legal entity. It is operationalized through IEBC Act 2011.

The IEBC Act provides that the funds of the Commission are held in a fund known as the Independent Electoral and Boundaries Commission Fund. The fund has not been operationalized.

The Commission is required to prepare and submit its annual financial statements to the Auditor General by 30th September every year and a copy to the Controller of Budget, the National Treasury and the Commission of Revenue of Allocation as stipulated in Section 81 of the Public Finance Management Act, 2012.

3. Key Management

The Commission's day-to-day activities are run by the Secretariat. The secretariat's management was as follows:

(a) Marjan H. Marjan	Commission Secretary/CEO.
(b) Ruth Kulundu	Deputy Commission Secretary –Operations.
(c) Obadiah Keitany	Deputy Commission Secretary –Support Services.
(d) Osman Hassan Ibrahim	Director Finance.
(e) Lorna Agnes Onyango	Director Human Resources and Administration.
(f) Rasi Masudi	Director Voter Education, Partnerships & Communication.
(g) Dr. Catherine Kamindo	Director Research, Electoral Boundaries and Risk Management.
(h) Michael Ouma	Director Information and Communication Technology.
(i) Moses Sunkuli	Ag. Director Voter Registration and Elections Operations.
(j) Chrispine Owiye	Director Legal Affairs and Public Affairs.
(k) Reuben K. Chirchir	Ag. Director Internal Audit and Compliance.
(l) Harley K. Mutisya	Director Supply Chain Management.

4. Fiduciary Management

The key management personnel who held office during the 2021/2022 financial period ended 30th June, 2022 and had direct fiduciary responsibility were:

No.	Designation	Name
1.	Commission Secretary/CEO	Marjan H. Marjan.
2.	Deputy Commission Secretary – Operations.	Ruth Kulundu.
3.	Deputy Commission Secretary –Support Services.	Obadiah K. Keitany.
4.	Director Supply Chain Management	Harley K. Mutisya.
5.	Director Finance	Osman H. Ibrahim
6.	Ag. Director Internal Audit & Compliance	Reuben K. Chirchir.
7.	Director Human Resources & Administration	Lorna A. Onyango.
8.	Director Information & Communication Technology	Michael Ouma.
9.	Ag. Director Voter Registration & Elections Operations	Moses Sunkuli.
10.	Director Research, Electoral Boundaries & Risk Management	Dr. Catherine Kamindo.
11.	Director Voter Education, Partnerships & Communication	Rasi M. Masudi.
12.	Director Legal Affairs & Public Affairs	Chrispine Owiye.

5. Fiduciary Oversight Arrangements

Finance and Supply Chain Management Committee activities

The Commission has in place a Finance and Supply Chain Management Committee consisting of at least three Commissioners. The Committee has an oversight role over all finance and procurement matters. The Committee meets at least once a month.

Audit Committee activities

The Commission has in place an independent Audit Committee that is chaired by a non-executive member. The Audit Committee oversees the internal audit activity charged with the responsibility of continuous review and providing assurance on effectiveness of the Commission's Governance, Risk and Control.

Parliamentary Accounts Committee (PAC) activities

The Commission, in response to PAC invitation, explains any unresolved audit issues raised by the Auditor General. The Commission has received PAC recommendations up to 2019/2020 FY which are currently being implemented. The Commission is awaiting to appear before PAC for 2020/2021FY Auditor General Report.

Budget and Appropriation Committee

The Committee oversees the Commission on all matters related to coordination, control and monitoring of the of the budget proposals. It also discuss and reviews the estimates and make recommendations to the House for funding.

Development Partner Oversight activities

For the period under review, the Commission received support from IFES, which is implemented under Direct Implementation Method (DIM).

External/Statutory Audit Activities

The Commission is annually subjected to audit by the Office of the Auditor General as required by law. OAG undertakes; Continuous, Systems/Compliance and Annual audits on the Commission finances and operation activities. In special circumstances, OAG conduct Special Audits.

Budgetary Control Activities

The Office of Controller of Budget (COB) of Kenya is an independent office established to oversee implementation of the budgets of the National and County Governments by authorizing withdrawal from public funds.

The Commission files the required quarterly and annual budget implementation reports to the Officer of the Controller of Budget. Further, the Commission has put in place a standing committee on Budget Implementation which advises the Commission on budgetary matters.

The Commission is committed to compliance and prudence in the management of the finances, collaborates with the relevant statutory oversight institutions and continues to undertake internal financial reviews whose outcome enables the Commission to strengthen its operational and financial systems.

6. Commission Bankers

Central Bank of Kenya
Haille Sellasie Avenue
P.O. Box 60000-00200
NAIROBI.

Kenya Commercial Bank Ltd.
University Way Branch
P.O. Box 4012-00300
NAIROBI.

Cooperative Bank of Kenya Ltd
University Way Branch
P.O. Box 48231-00100
NAIROBI.

Housing Finance Company Bank Ltd
P.O. Box 30088-00100
NAIROBI.

7. Commission Auditors

The Auditor General
Kenya National Audit Office
Anniversary Towers
P.O. Box 30084- 00100
NAIROBI.

8. Commission Headquarters

The Independent Electoral and Boundaries Commission
Anniversary Towers, 6th Floor,
P.O Box 45371-00100
NAIROBI.

9. Principal Legal Advisor

The Attorney General
State Law Office
Harambee Avenue
P.O. Box 40112-00200
NAIROBI.

THE IEBC COMMISSION

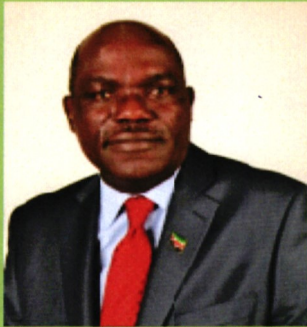

Chairperson: Mr. Wafula W. Chebukati

Key Qualifications:

- Master of Business Administration from Jomo Kenyatta University of Agriculture and Technology.
- Bachelor of Law Degree from the University of Nairobi.
- Post Graduate Diploma from the Kenya School of Law.
- Advocate of the High Court of Kenya.

Experience:

- Over 32 years' experience in legal practice specializing in litigation and dispute resolution, conveyancing, labour laws, company mergers and acquisitions, Maritime and treaties.
- Works on a full-time basis as a chairperson of the Commission.
- Chairs the Dispute Resolution Committee and the Electoral Code of Conduct Committee.

Vice Chairperson: Ms. Juliana Whonge Cherera



Key Qualifications:

- Master of Education, Leadership and Educational Management from Kenya Methodist University.
- Bachelor of Education (Arts). Honours from Kenyatta University.
- Dip. Project Management; KIM.
- Dip. Early Childhood Development Education (ECDE); KNEC.
- Strategic Leadership and Development Program; KSG
- Senior Management Course (SMC); KSG

Experience:

- Ms Cherera Has over 19 years' experience in Education and Management in the public sector.
- Before her appointment to the Commission, she worked as Chief Officer Executive in the Strategic Delivery Unit of the Mombasa County Government.
- Member of Mombasa County Emergency Household Relief and Nutrition Support Project Coordination Committee.
- Secretary to the Mombasa County Economic Recovery and Legacy Strategy.
- Member of Kenya Devolution Support Program Committee.
- Works on a full-time basis as a vice chairperson of the Commission.
- She Chairs the Voter Education, Partnerships and Stakeholders

Engagement Committee.

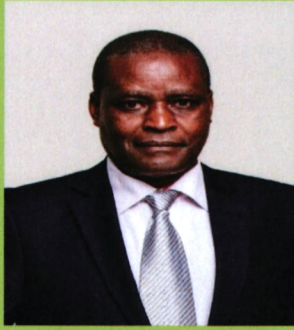

Commissioner: Francis M. Wanderi

Key Qualifications:

- Master of Science in Management (MSc. Mgmt.); from Arthur D. Little Management Institute at Boston, USA.
- Bachelor of Education; UoN.
- Transformative Leadership and Change Management.
- Corporate Governance Course by Commonwealth Association for Corporate Governance.

Experience:

- Over 33 years in senior management within public and private institutions characterized by integrity and a high performance, and with a proven track record in development and execution of strategy, people and change management and, leadership and innovation toward realization of organizational objectives and visions.
- Mr. Francis M. Wanderi is a former Chairperson of EPZ and director Roots Credit Ltd.
- He Chairs Finance and Supply Chain Management Committee.

Commissioner: Irene Cherop Masit



Key Qualifications:

- Master's degree in Strategic Human Resource Management from the University of Manchester, UK.
- Bachelor of Law degree - University of Nairobi.
- Bachelor of Arts degree in Social work -University of Nairobi.
- Post Graduate Dip from Kenya School of Law.
- Member of International Certified Addiction Professional (ICAP I-Treatment; Colombo Plan Global Centre for Credentialing and Certification.
- Member of Institute of Internal Auditors (IIA).
- Advocate of the High Court of Kenya.

Experience:

- Ms. Irene Masit has over 26 years work experience and knowledge in Government and Non – Governmental Organizations.
- She is the immediate former board member, National Government Constituency Development Fund (NGCDF).
- She has knowledge and experience in Finance, Governance, Management and Public Administration.
- Chairs the Legal, Compliance and Political Party Liaison Committee and the Leadership and Integrity Committee.

Commissioner: Prof. Abdi Yakub Guliye



Key Qualifications:

- PhD in Animal Nutrition from Rowett Research Institute/ University of Aberdeen, Scotland, UK.
- Master of Science in Animal Production from University of Aberdeen, Scotland, UK.
- Bachelor of Science in Animal Production from Egerton University.

Experience:

- Prof. Guliye has over 28 years of university teaching experience, of which in the last 8 years he had additional administrative/ managerial roles. He also served in various Boards of Institutions/Organizations, having chaired committees such as Audit and Risk Management as well as Finance.
- Chairs the Election Operations, Research and Boundary Delimitation Committee.

Commissioner: Mr. Justus Nyang'aya



Key Qualifications:

- Master of Arts (M.A) Education from the Institute of Education, University of London (IOE), UK.
- Diploma in Leadership, Governance, Peace and Conflict Transformation from the United Nations' University -International Leadership Academy in Jordan -Amman.
- He studied educational science in Kenya and Great Britain.

Experience:

- Mr. Nyang'aya has over 33 years of experience in Strategic Leadership, Governance and Social Accountability Organizations.
- He was director of Lead Africa, an organisation working for the Qualification of African Managers.
- Former Country Director, Amnesty International Kenya. Amnesty Kenya's work concentrates on the prevention of forced evictions, the protection of housing rights and women's rights.
- He also worked for the Netherlands Development Organisation as well as UNESCO.
- Chairs the Information and Communication Technology Committee.



Commissioner: Mr. Boya Molu

Key Qualifications:

- Master's in Business Administration (HR Management Option), Periyar University, India.
- Bachelor of Business Administration from Karnatak University, India.
- Higher National Diploma in Human Resources Management (KNEC), IHRM Kenya.

Experience:

- Has over 16 years' experience in Human Resource Management and administration mainly in public sector.
- Prior to joining the Commission Mr. Molu served in various capacities at the Central Bank of Kenya (CBK) and the Judiciary in Human Resource and Administration Directorate.
- Also served as a council member of the Institute of Human Resources Management (IHRM) Kenya.
- Chairs the Human Resource, Administration and Training Committee.

THE IEBC MANAGEMENT TEAM



CPA Marjan H. Marjan

CEO/Commission Secretary

Profession/Qualifications:

- MBA in Strategic Management - University of Nairobi (UoN);
- BCom (Accounting Option) - (UoN);
- Certified Public Accountant (CPA-K);
- Certified Information Systems Auditor (CISA);
- Certified Internal Auditor (CIA);
- Certification in Control Self-Assessment (CCSA)
- Certified Quality Assessor (CQA);
- Practicing Member of ICPAK in good standing;
- Member of Information Systems Audit & Control Association (ISACA);
- Member of Institute Internal Auditor (IIA).



CPA Obadiah K. Keitany

Deputy CEO/ Deputy Commission Secretary – Support Services

Profession/Qualifications:

- MBA Finance – University of Nairobi (UoN);
- BCom Insurance (UoN);
- Certified Public Accountant (CPA-K);
- Certified Internal Auditor (CIA);
- Certified Information Systems Auditor (CISA);
- Certified Public Secretary (CPS-K);
- Certified Quality Assessor (CQA);
- Post Graduate Diploma in Corporate Governance (KCA);
- Member of ICPAK in good standing;
- Member of Information Systems Audit & Control Association (ISACA);
- Member of Institute of Internal Auditors (IIA);
- Member of Institute of Certified Secretaries of Kenya.



Ruth Kulundu

Deputy CEO/Deputy Commission Secretary - Operations

Profession/Qualifications:

- MBA –Strategic Management- (UON).
- Bachelor of Commerce BCOM -(UoN);
- Associate of Chartered Insurance Institute - ACII (London).
- Associate of Chartered Insurance Institute - AIK (Kenya).
- Associate of Chartered Institute of Arbitrators (Kenya Chapter).



CPA Osman H. Ibrahim, OGW

Director Finance

Profession/Qualifications:

- MBA Finance – University of Nairobi (UoN);
- Bachelor of Commerce –UoN;
- Certified Public Accountant (CPA-K);
- Member of ICPAK in good standing.
- Member of IIA –Kenya in good standing;
- Member of Institute of Internal Auditor(IIA);

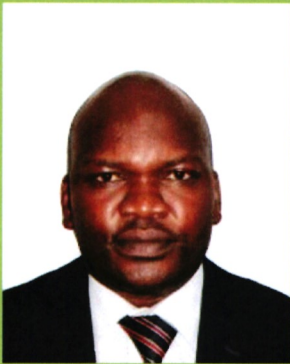

Chrispine Owiye

Director Legal and Public Affairs.

Profession/Qualifications:

- Master of Law in Law Governance and Democracy - University of Nairobi.
- Bachelor of Law degree (LLB) – Moi University;
- Post Graduate Diploma- Legal Education(Kenya School of Law);
- Certificate in Prosecution (CID Training School).
- Advocate of the High Court of Kenya;
- Member of the Law Society of Kenya;
- Commissioner for Oaths and Notaries Public.
- Member of the International Commission of Jurists.
- Member of the International Police Association.



Dr. Catherine M. Kamindo

Ag. Director Research Boundaries & Development

Profession/Qualifications:

- PhD Education Policy and Management- University of Durham (UK);
- Master of Education Educational Administration- Kenyatta University;
- Bachelor of Education - Kenyatta University;
- Certificate in Strategic Communication- The World Bank;
- Certificate in Management of Democratic Elections in Africa- University of South Africa;
- Professional Certificate in Electoral Processes-International Centre for Parliamentary Studies (UK);
- Full Member (FKIM) Kenya Institute of Management;
- African Union Certified Long and Short-Term Elections Observer;
- Kenya Association of Educational Administration (KAEM);
- American Political Science Association (APSA).

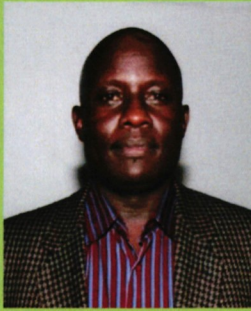

Moses Sunkuli

Ag. Director Voter Registration and Electoral Operations

Profession/Qualifications Profession/Qualifications:

- MBA, Strategic Management-Kenyatta University;
- Bachelor of education, Arts –Moi University;
- Diploma in Business Management- Kenya Institute of Management;
- Certificate, Management of Democratic Elections in Africa - UNISA;
- Strategic Leadership Management Course - Kenya School of Government;
- Member (KIM) Kenya Institute of Management.



Rasi Masudi

Director Voter Education, Partnerships & Communication

Profession/Qualifications:

- Executive MBA;
- Bachelor of Science in Agricultural Economics;
- Diploma in Farm Management.



Harley Kisyula Mutisya

Director Supply Chain Management

Profession/Qualifications:

- PHD in Business Administration (UoN);
- MBA in Procurement & Supply Chain Management (UoN);
- BCOM in Supply Chain Management (UoN);
- Diploma in Logistical Management from Cerford Institute;
- Certified Procurement and Supply Professional (CPSP-K);
- Chartered Associate (ACI Arb);
- Member Kenya Institute of Supplies Management (KISM);
- Certified Practitioner-(KISM);
- Fellow Logistics Society of Kenya;
- Member Chartered Institute of Procurement and Supply (UK);



Michael Ouma

Director ICT

Profession/Qualifications:

- MBA, Strategic Management – UoN;
- B. Tech. in Electrical & Communications Engineering – Moi University;



CPA Reuben Chirchir

Ag. Director Audit & Compliance

Profession/Qualifications:

- Master's in Business Administration in Finance (MBA)- USIU;
- Bachelor of Arts, BA(Hons), Economics - University of Nairobi;
- Certified Public Accountant (CPA-K);
- Member of ICPAK in good standing;
- Member of IIA –Kenya in good standing;



Lorna A. Onyango

Director Human Resource & Administration

Profession/Qualifications:

- Master of Business Administration (HRM);
- Post Graduate Diploma;
- Bachelor of Arts (Sociology) (UoN);
- Certificate, Human Resource Audit;
- Certificate, Payroll Management;
- Licensed Human Resource Professional;
- Member, Institute of Human Resource Management (IHRM), Kenya.

STATEMENT OF PERFORMANCE AGAINST OBJECTIVES FOR 2021/2022FY

Section 81 Sub-section 2 (f) of the Public Finance Management Act, 2012 requires the accounting officer to include in the financial statement, a statement of the national government entity's performance against predetermined objectives.

IEBC has three strategic pillars and objectives within its Strategic Plan for the FY 2019/2020-2023/2024.

These strategic pillars are as follows:

Pillar 1: Managing Elections.

Pillar 2: Institutional Transformation.

Pillar 3: Trust and Participation.

The Commission develops its annual work plans based on the above three pillars. Assessment of the Commission's performance against its annual work plan is done on a quarterly basis. The Commission achieved its performance targets set for its 2020-2024 strategic pillars, as indicated in the table below:

Strategic Pillar	Objective	Key Performance Indicators	Activities	Achievements
Pillar 1: Managing Elections	Strengthen Electoral, Legal framework and Enforcement.	All Electoral Laws reviewed and harmonized by August. The percentage reduction in reported cases of electoral offences by Political Parties, Candidates and other Stakeholders.	Workshops Public participation JLAC for consultation on the Commission's proposals. Stakeholder engagement with IEBC External Counsel.	-Developed Comprehensive Matrix of Proposals developed and draft bill discussed with Stakeholders. -Submitted the four draft bills to parliament; <ul style="list-style-type: none"> • Draft Elections (General) Regulations, 2022. • Draft Elections (Voter education) Regulations, 2022. • Draft Elections (Technology) Regulations, 2022. • Draft (Registration of voters) Regulations, 2022. • Draft Elections (Party Primaries and Party Lists) Regulations, 2022.
	Enhance compliance in electoral processes.	Number of election disputes heard and determined.	Staff, tribunal, advocates.	325 election disputes.

Strategic Pillar	Objective	Key Performance Indicators	Activities	Achievements
	Elections operations implemented for enhanced voter experience.	Conduct all by-elections within the statutory timelines.	<ul style="list-style-type: none"> Sourcing of election materials. Training of Election officials. Nominations. Polling. Tallying. 	Nine (9) by-elections conducted, one (1) Member of the National Assembly and five (5) Members of County Assembly and 3 other elections i.e. 1 Red cross. 1 Law Society of Kenya. 1 Judiciary.
		Number of candidates registered for elections	<ul style="list-style-type: none"> Sourcing of materials. Training of Election officials. Registration. 	16,105
		Number of new Polling Stations created	Sourcing of materials. Training of Election officials. Equipment, forums and workshops.	5,373
	Register eligible Kenyan Citizens as voters.	Number of eligible voters registered.	<ul style="list-style-type: none"> Continuous voter registration. Continuous cleaning of register. 	New registered voters 2,743,594 Total registered voters 22,464,755.
	Equity in Representation in Parliament and County Assembly levels. Delimitation of Electoral Areas.	Review of Electoral Boundaries.	<ul style="list-style-type: none"> Stakeholder participation. Forums Consultations with relevant authorities. 	Draft Strategy in Voter Education, Partnership and Communication Strategy Development. 5,346 Number of GPS coordinates collected for the gazette registration centers.
Pillar 2: Institutional Transformation				

Strategic Pillar	Objective	Key Performance Indicators	Activities	Achievements
	Strengthen corporate governance and communication in IEBC.	A risk-based Annual Internal Audit Plan developed and implemented. Quarterly progress reports on risk management Developed. The IEBC Risk Register reviewed.	<ul style="list-style-type: none"> Development of annual audit plan. Continuous audit reviews Quarterly Risk review plans Desktop reviews. 	<ul style="list-style-type: none"> 10 Quarterly internal audits. 12 Risk Reviews conducted. IEBC Risk Register Updated. 10 audit reports issued.
	Provide adequate office space and a conducive work environment.	Acquire and own office facilities for the IEBC Headquarters and field offices by 2020.	Sourcing funds Office reallocation Construction of warehouses and county and constituency offices.	<ul style="list-style-type: none"> Constructed of 5 county warehouses (Wajir, Garissa, Kakamega, Machakos, Isiolo counties). Developed a preliminary report on the construction of the Uchaguzi Centre.
Pillar 3: Trust and Participation	Empower Kenyans to Effectively participate in the electoral process.	Percentage of Kenyans directly or indirectly reached with voter education information prior to an electoral activity.	<ul style="list-style-type: none"> Continuous voter education. Review Workshops and for an advertisements. 	<ul style="list-style-type: none"> 55 % voter turnout in the by elections 43% voter turnout during voter registration.
	Strategic Partnership and Collaboration with Stakeholders.	Accreditation of election observers during key electoral processes.	<ul style="list-style-type: none"> Briefings. Accreditations. 	<ul style="list-style-type: none"> 69 observers for 6 by-elections. 15,157- Long Term Observers.
	Empowering political parties and independent candidates to effectively participate in the electoral Process.	Strengthen collaboration with the Office of the Registrar of Political Parties.	<ul style="list-style-type: none"> Political party liaison meeting. Training of political parties. 	<ul style="list-style-type: none"> Collaboration framework approved.
	Enhanced mechanisms for liaison with Political Parties.	Number of Political Parties Liaison Committee (PPLC) meetings held.	<ul style="list-style-type: none"> Meetings. Stakeholder forums. 	<ul style="list-style-type: none"> Six (6) Political Parties Liaison Committee (PPLC) meetings held in the period under review.

CORPORATE GOVERNANCE STATEMENT

The Commission is accountable to the public and stakeholders through Parliament for ensuring that it complies with the highest standards of corporate governance and operational ethics. The Commission has embraced corporate governance by promoting the right corporate culture and values.

The Commission exercises reasonable care to ensure that the management of the Commission is carried out in the best interest of the citizens of Kenya. The overall management of the Commission is the responsibility of the Commissioners.

The Commission recognizes the need to conduct its affairs with integrity and in accordance with generally accepted corporate practices and internationally developed principles of corporate governance.

The Commission

The size, composition and appointment of the Commission is prescribed by Article 250 of the Constitution and by the IEBC Act 2011. Seven (7) Commissioners worked on a full-time basis during the year under review. Each Commissioner is appointed to serve for a single term of six years.

The Commission is well composed in terms of range and diversity of skills, knowledge, age and experience in various sectors which makes it effective and provides an appropriate skills balance for the oversight of the Commission's mandate.

The Commission Committees and their Responsibilities

The Commission delegates certain functions to committees without abdicating its own responsibilities. The Commission has developed a committee structure that assists in the execution of its duties, powers and authorities. The Committees are appropriately constituted drawing membership from amongst the Commissioners with the appropriate set of skills and experience and directors co-opted from various directorates.

The Commission has in place an independent Audit Committee that is chaired by a non-executive member. It also has two independent audit committee members and one Commissioner.

The Audit Committee: Oversees the internal audit activity charged with the responsibility of continuous review and providing assurance on effectiveness of the Commission's Governance, Risk and Control.

Human Resource Training and Administration Committee: Provides advisory and oversight on human resource management, training and development, facilities and general administration.

Finance and Supply Chain Management Committee: The main role of the Finance and procurement Committee is to provide financial oversight for the Commission. The responsibilities include oversight over; Budgeting and budgetary control, Procurement, Financial management and reporting. It ensures compliance with relevant laws, Regulations and international standards especially Public Financial Management (PFM) Act, Public Procurement and Asset Disposal (PPAD) Act and Accounting Standards.

Election Operations, Research and Boundaries Delimitation Committee: Provides oversight on voter registration and election operations planning, boundary delimitation and risk monitoring and compliance.

Information and Communication Technology Committee: Provides oversight on the formulation and integration of ICT in the management of elections and research and planning.

Legal, Compliance and Political Party Liaison Committee: Oversees settlement of disputes relating to or arising from nominations, electoral code of conduct, campaign finance and code of ethics compliance. It also provides oversight on legal reforms, implementation of regulations and corporate governance.

Voter Education, Partnerships and Stakeholders Engagement Committee: Provides oversight on voter education, Partnerships, stakeholder engagement policies and strategies.

During the period under review, the Commission conducted the following committee meetings as per the table below;

S/No.	Committee	Key Responsibility	No. of Meetings
1.	Plenary.	Oversight, Strategy and Policy Formulation.	18
2.	Finance and Supply Chain Management Committee.	Procurement and Finance Oversight.	7
3.	Audit, Risk and Compliance Committee.	Oversight on Governance, Risk and Compliance.	3
4.	Human Resources, Training and Administration Committee.	Advisory and Oversight on Human Resource functions.	13
5.	Legal, Compliance and Political Party Liaison Committee.	Legal Oversight and Compliance.	6
6.	Information and Communication Technology Committee.	Oversight on Election Planning and Implementation.	4
7.	Election Operations, Research and Boundaries Delimitation Committee.	Technical oversight on voter registration and election operations planning, boundary delimitation and review.	2
8.	Voter Education, Partnerships and Stakeholders Engagement Committee.	Oversight on voter education, Partnerships, stakeholder engagement policies and strategies.	4

Impartiality and Independence of Members

Every member of the Commission and employee shall perform their functions impartially and independently without influence from any person, authority or organization.

Disclosure of Conflict of Interests

If a member of the Commission or an employee is directly or indirectly interested in any matter before the Commission and is present at any meeting of the Commission at which the matter is the subject of consideration, he/she shall as soon as practicable disclose the fact and shall not take part in the consideration or discussion of, or vote on, any questions with respect to the matter or be counted in the quorum of the meeting during consideration of the matter.

A member or employee whose personal interest conflicts with their official duties shall in writing, declare as soon as practicable the personal interests to their supervisor or other appropriate person or body and comply with any directives given to avoid the conflict and refrain from participating in any deliberations with respect to the matter.

MANAGEMENT DISCUSSION AND ANALYSIS

Operational and Financial Performance

The Commission successfully conducted (6) by-elections during the 2021/2022 financial year. These were one (1) Members of National Assembly and five (5) Member of County Assembly. The Commission further undertook Enhanced Continuous Voter Registration in which 2,743,594 new voters were registered. In addition, the Commission undertook verification of the Register of Voters and Candidate registration for the 2022 General Election of which 16,105 candidates were registered to contest for elections.

Summary of Budget Performance for the Year Ended 30th June 2022

The Commission was allocated Kenya shillings twenty three billion, one hundred and sixty five million five hundred and ninety one thousand, seven hundred and seventy five shillings (Kshs.23,165,591,775) in the printed estimated during the FY2021/22.

Through supplementary budget estimates, the budget was increased by eight million, eight hundred and thirteen thousand, nine hundred thousand and five hundred and fifty seven shillings (Kshs. 8,813,903,557) resulting to a revised budget of Kenya shillings twenty three billion, one hundred sixty five million, five hundred and ninety one thousand, seven hundred and seventy five (Kshs. 23,165,591,775).

Table 1 below indicates the overall budget performance for the Commission.

Table 1: Commission's Overall Budget

Description	Printed Estimates Kshs.(M)	Supplementary budget Kshs. (M)	Revised Budget Kshs.(M)
IEBC Vote 2031 (Recurrent)	14,226.69	8,813.90	23,040.59
IEBC Vote 2031 (Development)	125.00	-	125.00
Grand Total	14,351.69	8,813.90	23,165.59

Figure 1: The bar graph below illustrates the overall budget

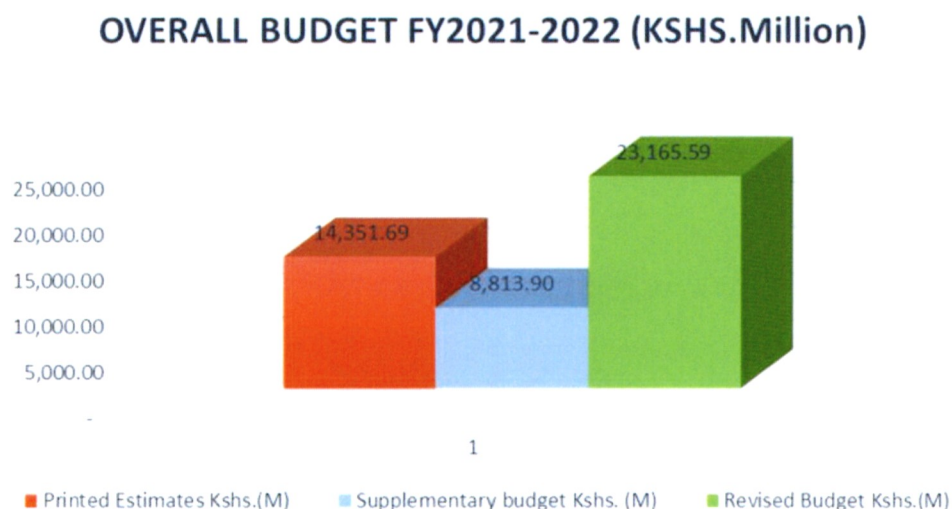

During the FY2021/2022 and in execution of its mandate, the Commission spend a total of Kshs.19, 682,558,581.90 (nineteen billion six hundred and eighty two million, five hundred and fifty eight thousand five hundred and eighty-one shillings). Table 1 below indicates the budget allocation Vs the budget utilization by sub-programmes during the FY2021/2022.

Table 1: Budget Allocation Vs Budget Expenditure by Sub- Programmes

Sub-Programme Description	Approved Budget (Kshs)	Actual Payments (Kshs)	Unutilized Budget (Kshs)
General Administration Planning and Support Services	4,101,095,180	3,768,581,038.05	332,514,141.95
Voter Registration and Electoral Operations	11,750,804,649	9,424,306,205.65	2,326,498,443.35
Voter Education and Partnerships	1,309,197,256	1,144,496,193.40	164,701,062.60
Electoral Information and Communication Technology	5,902,498,083	5,269,038,208.90	633,459,874.10
Delimitation of Electoral Boundaries	101,996,607	76,136,935.90	25,859,671.10
Grand Total	23,165,591,775.00	19,682,558,581.90	3,483,033,193.10

Fig.2: The bar graph below illustrates Budget Allocation Vs Budget Utilization by Sub-Programmes.

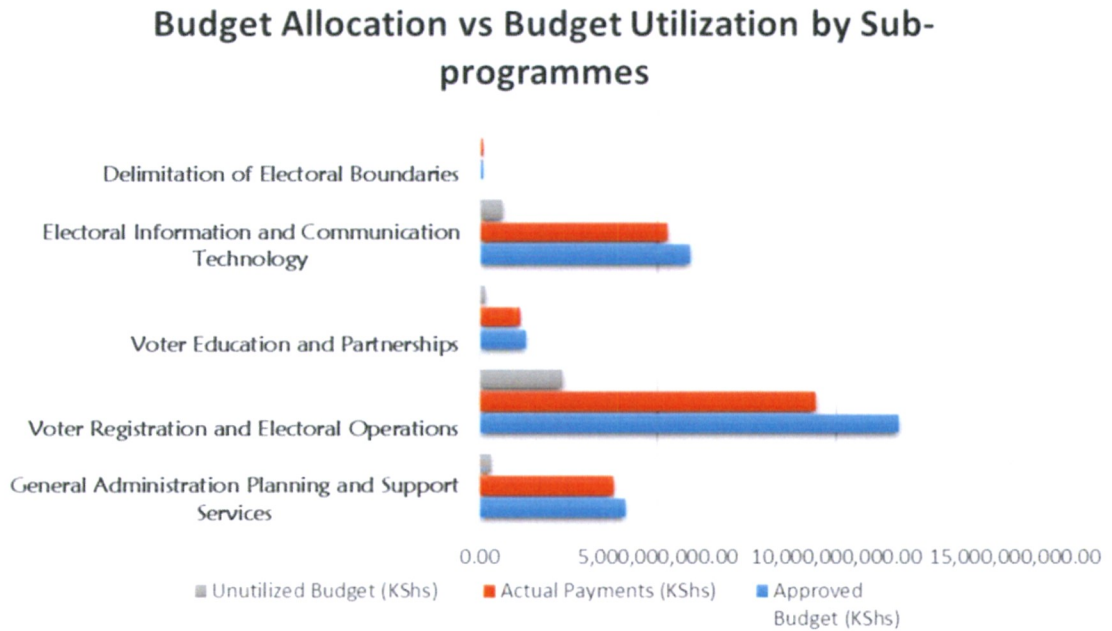
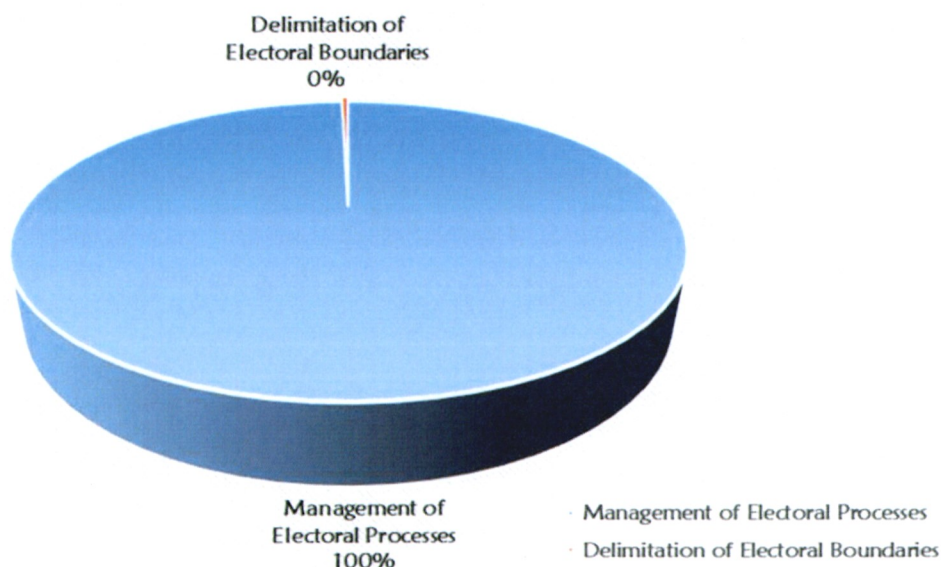

Table 2 below indicates the budget allocation Vs the budget utilization by economic classification during the FY2021/2022.

Table 2: Budget Allocation Vs Budget Expenditure by Programmes

S/No.	Description	Approved Budget (Kshs)	Actual Payments (Kshs)
1	Management of Electoral Processes	23,063,595,168.00	19,606,421,646.00
2	Delimitation of Electoral Boundaries	101,996,607.00	76,136,935.90
	Grand Total	23,165,591,775.00	19,682,558,581.90

Fig.3: The bar graph below illustrates Budget Allocation by Programmes



During the period under review, the Commission was allocated Kshs. 23,165,529,000 in both recurrent and development expenditures. The Commission received exchequer of Kshs. 19,641,465,000 and other internally generated income of Kshs. 143.45 million totalling to Kshs. 19.785 billion. The funds were utilized to fund the conduct of the by elections, general election activities, purchase of election equipment's and materials and construction of five (5) office buildings and other administrative operations of the commission.

The Commission continued to settle 2017 General Election pending bills amounting Kshs. 429.611,000. However, due to budgetary constraints, the Commission was unable to settle pending bills of Kshs 2.05 billion as of 30th June, 2022. Outstanding bills of Kshs.182 million were accrued during the year under review. A detailed listing of these bills has been provided as an annex to this report.

Compliance with Statutory Requirements

The Commission complied with its tax obligations and all its statutory obligations in the implementation of its mandate.

Key Projects and Investment

The Commission continued the construction of five (5) county warehouses in Garissa, Wajir, Isiolo, Kakamega and Machakos counties. The Commission had planned to construct its own building to house its head office to enhance security and efficiency in its operations. However, the project was not funded during the period under review. The Commission will continue to pursue funding to implement the project since the Commission headquarter offices are currently

located in a rented building, which is not conducive for its operations due to congestions, uncontrolled movement in and out of the offices and disruptions to the business enterprises during heightened political activities.

Risk Management Activities

The Commission has put in place a risk management framework for risk identification and mitigation. Further, it has embedded risk management in all its planning, execution, evaluation and business continuity arrangements.

Some of the key risks facing the Commission include:

- **Strategic Risks:** These are risks that affect the ability to carry out the long-term goals and objectives as articulated in the IEBC Policy.
- **Compliance Risks:** These are risks associated with non-compliance with applicable laws and regulations which could result in litigation and conflicts of interest.
- **Political Risks:** This is a major risk factor affecting staff performance and safety. These risks could also be attributed to political perception of major political parties on the Commission's role.
- **Reputational Risks:** The risk of significant negative public opinion and or perception that results in a critical loss of confidence in the institution.
- **Financial Risks:** The risk of financial loss that may include ineffectiveness of internal controls, financial processes for reporting, budgeting, and fiscal stewardship as well as the monitoring of full financial and performance reporting. These risks may also affect the ability to acquire assets, technology, etc.
- **Technological Risks:** This a possibility of failure of technology employed by the Commission in the conduct of elections and rapid technological change resulting to obsolescence.
- **Operational Risks:** The risk of direct or indirect loss or inability to provide core services, especially to stakeholders, resulting from inadequate or failed internal processes, resources (including human resources, equipment malfunction), and systems.

Statutory and Financial Obligations

As at the 30th June, 2022, the Commission had pending bills amounting Kshs. 2.051 billion.

Financial Probity and Governance

To obtain assurance on compliance and prudence in the management of the election finances, the Commission has collaborated with the relevant statutory oversight bodies and continues to undertake internal financial reviews whose outcome enables the Commission to strengthen its operational and financial systems.

ENVIRONMENTAL & SUSTAINABILITY REPORTING

The Independent Electoral and Boundaries Commission is a credible electoral management body that strives to meet the democratic aspirations of the people of Kenya.

Our Mission is to conduct transparent, efficient, and impartial elections; and undertake boundary delimitation for equitable representation and sustainable democracy.

In its endeavors to achieve its mandate, the Commission is guided by the following principles and core values:

- Adherence to the rule of law - We conduct our businesses within the law.
- Inclusivity - We respect gender, race, class and disability in the conduct of electoral activities.
- Integrity - We conduct our affairs with utmost honesty.
- Accountability - We endeavor to be responsible for our actions.
- Teamwork - We work collaboratively as colleagues to achieve Commission goals.
- Innovativeness - We transform the electoral process by exceeding the expectations of Kenyans.

i. Sustainability strategy and profile

The Independent Electoral and Boundaries Commission is a Constitutional body established under Article 88 of the Constitution of Kenya and is a body corporate pursuant to Article 253 of the Constitution of Kenya.

The Constitution of Kenya 2010, IEBC Act 2011 and the Elections 2011 have been the greatest sustainability pillars of the Commission and the achievements of its mandate. The National Assembly has enacted and or amended several Statutes that enable the Commission to carry out its mandate. The role played by the State and Non-State Stakeholders and Partners in the election process have sustained the operations and the implementation of the key commission strategies.

To effectively sustain its operations, the Commission has put in place structures, strategies, policies and procedures to support its operations. In the achievement of its mandate, the commission has anchored its operations and strategy in three main pillars: Managing of elections, institutional transformation and enhancing of public trust.

The Commission, over the years has developed well-trained and experienced staff on matters election operations and technology. To this end, it has received benchmarking delegations from Africa and beyond. Further, it has well established structures in its county and constituency offices spread across country.

ii. Employee welfare

The Commission policy on recruitment ensures the Commission's commitment to ensuring that the one third-gender rule is observed as well promotes affirmative action to ensure diversity in the workplace. The Commission's Shortlisting and Interview Guidelines ensure that recruitment processes are geared towards observing and promoting regional and gender balance.

Currently the percentage gender distribution is 35% female and 65% male, while the ethnic representation within the Commission is forty-three (43) ethnic tribes out the forty-six (46)

existing ethnic communities. The commission had seven workers with disabilities of which two were female while 5 were male. The Commission supports officers to be in good professional standing with their professional bodies by facilitating their Annual Subscription and Continuous Professional Development (CPD) training. In addition, the staff are trained in career development courses, specialized skills and seminars and workshops.

The Commission has a robust Performance Management System (PMS) that include Target Setting and the Annual Performance Appraisals. The Commission also recommend honors, awards, and issues commendation letters in recognition of exemplary performance.

iii. Market place practices

The Commission operates in an environment with a wide range of risk profiles, making free and fair election competitive focus in a very competitive elective political environment. Election code of conduct provides the commission and the public with details of malpractices that may impair competitive elections. It provides guidelines, addressing such issues as election fraud, bribery, violence, conflicts of interest, among other election irregularities.

The Commission has consistently applied the most competitive procurement method based on the prevailing procurement laws and regulation with emphasis on maximizing value for money and equity in the procurement processes. The Commission also conducts due diligence on third parties to ensure that it engages the right supplier in its procurement.

The Commission has established responsible supplier relationship by strict compliance to the public procurement and asset disposal processes and principles as laid down in the public procurement and asset disposal legislative framework. Further, the Commission has enhanced its communication as a tool in bettering the management of the existing suppliers. The use of online procurement modules has further enhanced efficiency hence increased trust in our procurement process. This has made suppliers to have a better understanding of the Commission's business goals.

CORPORATE SOCIAL RESPONSIBILITY (CSR)

The Commission's overriding Corporate Social Responsibility theme is "Connecting with the Voter".

In the period under review, the Commission undertook several CSR initiatives most of with other humanitarian initiatives.

- i. Donation of sanitary towels to various Schools.
- ii. Donation of sanitizers and facemasks to schools and the public.
- iii. Donation of books, Geometrical Sets, Pens and White Board to schools.
- iv. Sponsoring football tournaments for schools.
- v. Visiting children homes and donating of foodstuffs.
- vi. Open-air markets clean up.
- vii. Wall painting in a school.
- viii. Donation of soft drinks and snacks to a school of the deaf.
- ix. Painting of school gate and donation of iron sheets for two classrooms.
- x. Donation of IEBC branded hand washing tanks and soaps to schools.
- xi. Cleaning of the environment.
- xii. Donation of football materials for a local football team.
- xiii. Donation of water tanks to schools.
- xiv. Distribution of IEBC branded bags and pens to students and teacher.

Further, the Commission has institutionalized the management of school student council elections, where the Commission uses the opportunity to inculcate democratic tenets in the learner's minds. The school council elections are regularly coordinated by the Commission's County and constituency offices in their respective electoral area.

STATEMENT OF THE ACCOUNTING OFFICER RESPONSIBILITIES

Section 81 of the Public Finance Management Act, 2012, requires the Accounting Officer to prepare financial statements for each financial year that give a true and fair view of the state of affairs of the Commission as at the end of period and of its operating results. It also requires the Accounting Officer to ensure that the Commission maintains proper accounting records that disclose, with reasonable accuracy at any time, the financial position of the Commission. The Accounting Officer is also responsible for safeguarding the Commission's assets.

The Accounting Officer is responsible for the preparation and fair presentation of these financial statements in accordance with International Public Sector Accounting Standards (IPSAS) and in a form that complies with the standards prescribed by the Public Sector Accounting Standards Board (PSASB). This responsibility includes: designing, implementing and maintaining internal controls relevant to the preparation and fair presentation of financial statements that are free from material misstatement, whether due to fraud or error, safeguarding the assets, selecting and applying appropriate accounting policies, and making accounting estimates that are reasonable in the circumstances.

The Accounting Officer accepts responsibility for financial statements, which have been prepared using appropriate accounting policies supported by reasonable and prudent judgments and estimates, in conformity with International Public Sector Accounting Standards (IPSAS), and in the manner required by the PFM Act, 2012. The Accounting Officer is of the opinion that the financial statements give a true and fair view of the state of financial affairs of the Commission and of its financial position. The Accounting Officer further accept responsibility for the maintenance of accounting records that may be relied upon in the preparation of financial statements, as well as adequate systems of internal financial control.

Nothing has come to the attention of the Accounting Officer to indicate that the Commission will not remain a going concern for at least the next twelve months from the date of this statement.



CPA Marjan Hussein Marjan

Commission Secretary/CEO

REPORT OF THE CHAIRPERSON

I am pleased to present the Commission's annual financial statements for the period ended 30th June 2022.

The Commission successfully conducted six (6) by-elections during the 2021/2022 financial year. These were for the position of a Member of National Assembly and five Members County Assembly. The Commission further undertook Enhanced Continuous Voter Registration (ECVR) exercise of which 2,743,594 new voters were registered, Register of Voter verification and candidate's registration for the 2022 General Election.

In the 2021/2022 financial year, the Commission was allocated Kshs. 22.9 billion under the recurrent vote and Ksh.125 million under development vote. The Commission received exchequer amounting Kshs. 19.5 billion for recurrent expenditure and Kshs.111.6 million for development expenditure. Further, income of ksh.143 million was generated internally from the candidate's registration fees and disposal of boarded items.

Looking forward to the National Treasury to provide adequate budget allocation and timely release of exchequer to fund the settlement pending bills amounting Kshs. 2.0 billion some of which continue to attract interest due to non-payment.

I wish to register and applaud the Members and Staff of the IEBC as well as all partners and stakeholders for their support towards fulfilling Commission's mandate as enshrined in the Constitution of Kenya.

In Conclusion, I sincerely convey the gratitude of the Commission to the National Government, the National Treasury, Parliament, partners, stakeholders and staff of the Commission for their continued support towards fulfilling our mandate.

.....
W.W. Chebukati

Chairperson

REPORT OF THE SECRETARY/CHIEF EXECUTIVE OFFICER

The Independent Electoral and Boundaries Commission, hereby, submits its annual financial statements for the period between 1st July, 2021 and 30th June, 2022. During this period, the Commission was allocated a total of Kshs. 22.941 billion for recurrent expenditure and Kshs. 125 million for development to facilitate implementation of the Commission's programmes, activities and projects. Further, the commission internally generated incomes amounting to Kshs. 149 million from candidates'/nomination registration fees, and auction and disposal of boarded items.

The annual financial statements comprise of the Statement of the Financial Performance, Statement of the Financial Position, Statement of Changes in Net Assets, Statement of Cash Flows and Statement of Combined Budget Execution. The Commission has continued to ensure probity and prudence in the management of its resources in accordance with the provisions of the Public Finance Management Act (PFM), 2012 and the attendant regulations. The Statements of the Commission are also prepared in conformity with the International Public Sector Accounting Standards (IPAS) on prudent financial management and reporting.

Legally, the mandate of the Commission is derived from Article 88 of the Constitution of Kenya, 2010 and statutory instruments that include; the IEBC Act, 2011, the Elections Act, 2011 and the attendant election regulations. The Commission is responsible for enforcing the Electoral Code of Conduct and monitoring compliance relating to the nomination of candidates by parties. It also conducts investigation of electoral malpractices in Kenya.

More so, the Mission of the Commission is to conduct transparent, efficient, and impartial elections; and undertake boundary delimitation for equitable representation and sustainable democracy. This is reflected in the conduct of the elections and the election related activities in a manner that consistently delivers the desired results. During the reporting period, the Commission successfully conducted six (6) by-elections consisting of (1) Member of the National Assembly and five (5) Members of County Assembly. In addition, the commission conducted three (3) elections for other constitutional bodies.

Besides, the Commission conducted enhanced continuous voter registration, updated the roll/register of voters which realised 2,743,594 new voters, verification of register of voter in which 5,334,483 verified their details. Consequently, the registered number of voters stood at 22,464,755 as at 30th June, 2022. Additionally, the commission registered 16,105 candidates for 2022 general elections.

It is prudent to also note that public trust and participation are key pillars in the Commission's strategic direction aimed at instilling confidence and trust in the electoral processes among citizens. In cognizance of this, the Commission has continued to work very closely with various electoral stakeholders to ensure transparency and inclusivity in the electoral process. During the reporting period, the Commission accredited 389 observers for the by-elections, and 1,517 as long-term observers for the general election.

As regards risks management and assurance, the Commission recognizes that the two are important corporate governance pillars. To this end, the Commission has embedded a robust risk management framework in all its operations and functions. Furthermore, the Commission has put in place continuous risks assessment and mitigation strategies to enhance internal controls and compliance. The Commission has also undertaken enterprise wide risks management trainings, established a Risks Register and continuous review of the Commission's processes and operations.

Finally, I wish to sincerely appreciate the Commission Chairperson, Commissioners and members of staff for their relentless dedication and commitment in the realization of the Commission's set-out goals and objectives. I am also obliged to all partners and stakeholders for their immense support towards the fulfilment of the Commission's mandate as enshrined in the Constitution of Kenya, 2010. Indeed, building a better electoral body demands concerted efforts from both the internal and external actors. I request everyone to carefully read and analyse these statements and provide invaluable feedbacks to gear the Commission forward.



CPA Marjan Hussein Marjan

Commission Secretary/CEO

REPORT OF THE INDEPENDENT AUDITOR

STATEMENT OF FINANCIAL PERFORMANCE

For the Year ended 30th June, 2022			
	Note	2021/2022 Unaudited Kshs 000	2020/2021 Audited Kshs 000
<u>Incomes</u>			
Transfers from Other Governments	1	19,641,645	4,991,329
Other Incomes	2	143,463	3,556
Total Incomes		19,785,109	4,994,885
<u>Expenses</u>			
Use of Goods & Services	3	(7,820,946)	(1,256,940)
Employee Costs	4	(5,964,490)	(2,828,972)
Commissioners Expenses	5	(26,038)	(7,082)
Depreciation & Amortization	6	(1,506,092)	(629,496)
Repairs & Maintenance	7	(463,351)	(109,067)
Total Expenditure		(15,780,917)	(4,831,557)
Surplus in the Year		4,004,192	163,328

The significant accounting policies and notes to the financial statements on page 41 to 57 form an integral part of these financial statements.

STATEMENT OF FINANCIAL POSITION

As at 30th June, 2022			
	Note	2021/2022 Unaudited Kshs 000	2020/2021 Audited Kshs 000
Assets			
<u>Current Assets</u>			
Cash and Cash Equivalents	8	597,768	131,519
Receivables from Non-Exchange Transactions	9	41,856	16,972
Accounts Receivable	10	11,160	11,160
Car Loan Accounts Receivable	11	26,193	26,193
Inventory	12	907,560	-
		1,584,537	185,844
<u>Non-Current Assets</u>			
Property, Plant & Equipment	13	2,966,356	1,763,351
Intangible Assets	14	1,152,660	1,386
		4,119,016	1,764,737
<u>Total Assets</u>		5,703,554	1,950,581
<u>Current Liabilities</u>			
Accounts Payable	15	(2,051,567)	(2,299,626)
Provision for Gratuity	16	(31,604)	(19,330)
Refundable Deposits	17	(53,392)	(43,909)
Total Current Liabilities		(2,136,563)	(2,362,865)
Net Assets/(Liabilities)		3,566,991	(412,284)
<u>Financed by:</u>			
Accumulated Fund		726,765	766,366
Revenue Reserve		2,825,541	(1,178,651)
Capital Reserve		14,686	-
Net Assets/(Liabilities)		3,566,991	(412,285)

The significant accounting policies and notes to the financial statements on page 41 to 57 form an integral part of these financial statements.

The financial statements from page 36 to 40 were approved and authorized by the Commission and signed on its behalf by:

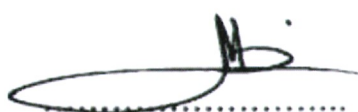

CPA Marjan H. Marjan
ICPAK M/No. 2786
Commission Secretary



CPA Osman H. Ibrahim
ICPAK M/ No. 2544
Director Finance

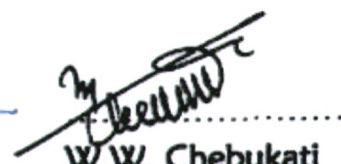

W.W. Chebukati
Chairperson

STATEMENT OF CASH FLOWS

As at 30th June, 2022			
	Note	2021/2022 Unaudited Kshs 000	2020/2021 Audited Kshs 000
<u>Cash flows from Operating Activities:</u>			
Operating Surplus/(Deficit)		4,004,192	163,328
Transfers to Exchequer	18	(39,602)	(32,699)
<u>Adjustments for Non-Cash Items:</u>			
Depreciation & Amortization	6	1,506,092	629,496
Computers Donated by IFES	13	14,686	-
Accruals Adjustment	15	-	57,337
Negotiation Savings	15	-	138,996
<u>Changes in Working Capital:</u>			
(Increase)/Decrease in Non-Exchange Transactions	9	(24,885)	4,931
(Increase)/Decrease in Election Inventory	12	(907,560)	-
Increase/(Decrease) in Accounts Payables	15	(248,059)	(825,188)
Increase/(Decrease) in Provision for Gratuities	16	12,274	(14,425)
Increase/(Decrease) in Refundable Deposits	17	9,483	6,910
Net Cash Flow from Operating Activities		4,326,621	128,688
<u>Cash flows from Investing Activities:</u>			
Purchase of Property, Plant & Equipments	13	(3,860,371)	(74,294)
Proceeds from Disposal of Equipment		-	62
Increase in Staff Mortgage & Car Loan Scheme	18	-	(11,384)
Net Cash Flow from Investing Activities		(3,860,371)	(85,616)
<u>Cash flows from Financing Activities:</u>			
Cash flows from Financing Activities		-	-
Net Cash Provided by Financing Activities		-	-
Net Decrease in Cash & Cash Equivalent		466,249	43,071
Cash & Cash Equivalent at Beginning		131,519	88,448
Cash & Cash Equivalents at the End	8	597,768	131,519

The significant accounting policies and notes on 41 to 57 form an integral part of these financial statements.

STATEMENT OF CHANGES IN NET ASSETS

For the Year Ended 30th June, 2022					
	Note	Capital Reserve	Revenue Reserve	Accumulated Fund	Total (Kshs)
		KShs. 000	KShs. 000	KShs. 000	KShs. 000
Balance as at 30th June 2020		<u>-</u>	<u>(1,330,596)</u>	<u>602,732</u>	<u>(727,864)</u>
Surplus/(Deficit) for the Year		-	163,328	-	163,328
2019/2020FY Funds Returned to N.Treasury	18	-	-	(32,699)	(32,699)
Rounding Off Variances		-	-	1.0	1.0
Accruals Adjustment & Credit Notes	15	-	-	57,337	57,337
Negotiation Savings		-	-	138,996	138,996
Transfers to Staff Car & Mortgage Fund	18	-	(11,384)	-	(11,384)
Balance as at 30th June 2021		<u>-</u>	<u>(1,178,651)</u>	<u>766,366</u>	<u>(412,285)</u>
Surplus/(Deficit) as at 30th June, 2022		-	4,004,192	-	4,004,192
2020/2021FY Funds Returned to N.Treasury	18	-	-	(39,602)	(39,602)
Computers Donated by IFES	13	14,686	-	-	14,686
Rounding Off Variances		-	-	0.5	0.5
Transfers to Staff Car & Mortgage Fund		-	-	-	-
Balance as at 30th June, 2022		<u>14,686</u>	<u>2,825,541</u>	<u>726,765</u>	<u>3,566,991</u>

The significant accounting policies and notes on 41 to 57 form an integral part of these financial statements.

STATEMENT OF COMPARISON OF BUDGET & ACTUAL AMOUNTS

IEBC BUDGET EXECUTION STATEMENT				
AS AT 30TH JUNE, 2022				
Item	Approved Annual	Actual Payments Annual	Variance Annual	Performance Percentage
<u>Incomes</u>	KShs '000	KShs '000	KShs '000	%
Exchequer Releases - Recurrent Vote 2031	22,940,591.78	19,530,010.24	3,410,582	85%
Exchequer Releases - Development Vote 2031	125,000	111,635.12	13,365	89%
Appropriation in Aid	100,000	143,463.46	(43,463)	143%
Total Income	23,165,592	19,785,108.82	3,380,483	85%
Management of Electoral Processes				
<u>Expenditure</u>				
Wages and Salary Contributions	4,333,774	4,211,103.82	122,670	97%
Social Contributions	203,643	129,801.27	73,842	64%
Goods and Services	13,389,657	10,584,410.50	2,805,247	79%
Routine Maintenance	1,266,326	1,070,868.84	195,458	85%
Social Security Benefits	3,164	3,000.09	163	95%
Acquisitions of Fixed Capital Assets	3,808,632	3,548,875.11	259,757	93%
Domestic Lending and On-lending	58,362	58,362.02	-	100%
Sub-Total	23,063,558	19,606,421.65	3,457,137	85%
Delimitation of Electoral Boundaries				
Wages and Salary Contributions	22,952	19,556.53	3,396	85%
Goods and Services	77,245	56,433.07	20,811	73%
Routine Maintenance	1,800	147.34	1,653	8%
Sub-Total	101,997	76,136.94	25,859.67	75%
Total Expenditure	23,165,555	19,682,558.58	3,482,996	85%

Note 19 (Budget Information & Other Disclosures) provides explanations on material utilization differences.

SIGNIFICANT ACCOUNTING POLICIES

For the Year Ended 30th June, 2022

1. Statement of compliance and basis of preparation – IPSAS 1

The Commission's financial statements have been prepared in accordance with and comply with the International Public Sector Accounting Standards (IPSAS). The financial statements are presented in Kenya shillings, which is the functional and reporting currency of the Commission and all values are rounded to the nearest thousand (Kshs 000) which may in some cases make the added decimal balances to vary. The accounting policies have been consistently applied in all the years presented.

The financial statements have been prepared on the basis of historical cost, unless where stated otherwise. The cash flow statement is prepared using the indirect method. The financial statements are prepared on accrual basis.

2. Summary of Significant Accounting Policies:

a) Revenue Recognition - Revenue from Non-Exchange Transactions (Fees, Charges and Fines) – IPSAS 23

The Commission recognizes revenues from nomination fees and fines when the event occurs, and the asset recognition criteria are met. To the extent that there is a related condition attached that would give rise to a liability to repay the amount, deferred income is recognized instead of revenue. Other non-exchange revenues are recognized when it is probable that future economic benefits or service potential associated with the asset will flow to the Commission and the fair value of the asset can be measured reliably.

Transfers from Other Government Entities

Revenues from non-exchange transactions with other government entities are measured at fair value and recognized on obtaining control of the asset (cash, goods, services and property) if the transfer is free from conditions and it is probable that the economic benefits or service potential related to the asset will flow to the Commission and can be measured reliably.

Interest Income

Interest income is accrued using the effective yield method. The effective yield discounts estimated future cash receipts through the expected life of the financial asset to that asset's net carrying amount. The method applies this yield to the principal outstanding to determine interest income each period.

b) Budget Information – IPSAS 24

The annual budget is prepared and presented in a single statement to determine the needs of the Commission. The Commission has adopted the standard which requires budget information to be presented in the financial statements.

SIGNIFICANT ACCOUNTING POLICIES (Continued)

For the Year Ended 30th June, 2022

c) Taxes – IAS 12

Income tax

Income tax assets and liabilities for the current period are measured at the amount expected to be recovered from or paid to the tax authorities. The tax rates and tax laws used to compute the amount are those that are enacted or substantively enacted, at the reporting date in the area where the Commission operates and generates taxable income.

Current income tax relating to items recognized directly in net assets is recognized in net assets and not in the statement of Financial Performance. Management periodically evaluates positions taken in the tax returns with respect to situations in which applicable tax regulations are subject to interpretation and establishes provisions where appropriate.

d) Property, Plant and Equipment – IPSAS 17

All property, plant and equipment are stated at cost less accumulated depreciation and impairment losses. Cost includes expenditure that is directly attributable to the acquisition of the items. When significant parts of property, plant and equipment are required to be replaced at intervals, the Commission recognizes such parts as individual assets with specific useful lives and depreciates them accordingly.

Likewise, when a major inspection is performed, its cost is recognized in the carrying amount of the plant and equipment as a replacement if the recognition criteria are satisfied. All other repair and maintenance costs are recognized in surplus or deficit as incurred. Where an asset is acquired in a non-exchange transaction for nil or nominal consideration the asset is initially measured at its fair value.

The depreciation rates are 30% for Computers, 25% for motor vehicles, 12.5% for office equipment and 12.5% for furniture and fittings on reducing balance basis.

e) Intangible Assets – IPSAS 31

Intangible assets acquired separately are initially recognized at cost. The cost of intangible assets acquired in a non-exchange transaction is their fair value at the date of the exchange.

Following initial recognition, intangible assets are carried at cost less any accumulated amortization and accumulated impairment losses. Internally generated intangible assets, excluding capitalized development costs, are not capitalized and expenditure is reflected in surplus or deficit in the period in which the expenditure is incurred.

The useful life of the intangible assets is assessed as either finite or indefinite.

The amortization rate for intangible assets of the Commission is 30% on reducing balance basis.

SIGNIFICANT ACCOUNTING POLICIES (Continued)

For the Year Ended 30th June, 2022

f) Research and Development costs

The Commission expenses research costs as incurred. Development costs on an individual project are recognized as intangible assets when the Commission can demonstrate:

- The technical feasibility of completing the asset so that the asset will be available for use or sale.
- Its intention to complete and its ability to use or sell the asset.
- How the asset will generate future economic benefits or service potential.
- The availability of resources to complete the asset.
- The ability to measure reliably the expenditure during development.

Following initial recognition of an asset, the asset is carried at cost less any accumulated amortization and accumulated impairment losses. Amortization of the asset begins when development is complete and the asset is available for use. It is amortized over the period of expected future benefit. During the period of development, the asset is tested for impairment annually with any impairment losses recognized immediately in surplus or deficit.

g) Provisions – IPSAS 19

Provisions are recognized when the Commission has a present obligation (legal or constructive) as a result of a past event, it is probable that an outflow of resources embodying economic benefits or service potential will be required to settle the obligation and a reliable estimate can be made of the amount of the obligation.

Where the Commission expects some or all of a provision to be reimbursed, for example, under an insurance contract, the reimbursement is recognized as a separate asset only when the reimbursement is virtually certain.

The expense relating to any provision is presented in the statement of financial performance net of any reimbursement.

h) Contingent Liabilities

The Commission does not recognize a contingent liability, but discloses details of any contingencies in the notes to the financial statements, unless the possibility of an outflow of resources embodying economic benefits or service potential is remote.

i) Contingent Assets

The Commission does not recognize a contingent asset, but discloses details of a possible asset whose existence is contingent on the occurrence or non-occurrence of one or more uncertain future events not wholly within the control of the Commission in the notes to the financial statements.

SIGNIFICANT ACCOUNTING POLICIES (Continued)

For the Year Ended 30th June, 2022

Contingent assets are assessed continually to ensure that developments are appropriately reflected in the financial statements. If it has become virtually certain that an inflow of economic benefits or service potential

will arise and the asset's value can be measured reliably, the asset and the related revenue are recognized in the financial statements of the period in which the change occurs.

j) Nature and Purpose of Reserves

The Commission creates and maintains reserves in terms of specific requirements. Commission to state the reserves maintained and appropriate policies adopted.

k) Changes in Accounting Policies and Estimates – IPSAS 3

The Commission recognizes the effects of changes in accounting policy retrospectively. The effects of changes in accounting policy are applied prospectively if retrospective application is impractical.

l) Employee Benefits – IPSAS 25

Retirement Benefit plans

The Commission provides retirement benefits for its full-time employees. It operates a defined contribution plan which is a post-employment benefit plan under which the Commission pays fixed contributions into a separate Commission (fund), and will have no legal or constructive obligation to pay further contributions if the fund does not hold sufficient assets to pay all employee benefits relating to employee service in the current and prior periods. The contributions to fund obligations for the payment of retirement benefits are charged against income in the year in which they become payable. The Scheme is administered by ICEA Lions Asset Management Ltd.

m) Foreign Currency Transactions – IPSAS 4

Transactions in foreign currencies are initially accounted for at the ruling rate of exchange on the date of the transaction. Trade creditors or debtors denominated in foreign currency are reported at the statement of financial position reporting date by applying the exchange rate on that date. Exchange differences arising from the settlement of creditors, or from the reporting of creditors at rates different from those at which they were initially recorded during the period, are recognized as income or expenses in the period in which they arise.

n) Cash and Cash Equivalents

Cash and cash equivalents comprise cash on hand and cash at bank, short-term deposits on call and highly liquid investments with an original maturity of three months or less, which are readily convertible to known amounts of cash and are subject to insignificant risk of changes in value. Bank account balances include amounts held at the Central Bank of Kenya and at various commercial banks at the end of the financial year.

SIGNIFICANT ACCOUNTING POLICIES (Continued)

For the Year Ended 30th June, 2022

o) Comparative Figures

Where necessary comparative figures for the previous financial year have been amended or reconfigured to conform to the required changes in presentation.

p) Significant Judgments and Sources of Estimation Uncertainty – IPSAS 1

The preparation of the Commission's financial statements in conformity with IPSAS requires management to make judgments, estimates and assumptions that affect the reported amounts of revenues, expenses, assets and liabilities, and the disclosure of contingent liabilities, at the end of the reporting period. However, uncertainty about these assumptions and estimates could result in outcomes that require a material adjustment to the carrying amount of the asset or liability affected in future periods.

Estimates and Assumptions

The key assumptions concerning the future and other key sources of estimation uncertainty at the reporting date, that have a significant risk of causing a material adjustment to the carrying amounts of assets and liabilities within the next financial year, are described below. The Commission based its assumptions and estimates on parameters available when the financial statements were prepared. However, existing circumstances and assumptions about future developments may change due to market changes or circumstances arising beyond the control of the Commission.

Such changes are reflected in the assumptions when they occur (IPSAS 1.140).

Useful Lives and Residual Values

The useful lives and residual values of assets are assessed using the following indicators to inform potential future use and value from disposal:

- The condition of the asset based on the assessment of experts employed by the Commission.
- The nature of the asset, its susceptibility and adaptability to changes in technology and processes.
- The nature of the processes in which the asset is deployed.
- Availability of funding to replace the asset.
- Changes in the market in relation to the asset.

Provisions

Provisions were raised and management determined an estimate based on the information available. Additional disclosure of these estimates of provisions is included in the note on provision for gratuity.

Provisions are measured at the management's best estimate of the expenditure required to settle the obligation at the reporting date, and are where applicable, discounted to present value where the effect is material.

q) Subsequent Events – IPSAS 14

There have been no events subsequent to the financial year end with a significant impact on the financial statements.

SIGNIFICANT ACCOUNTING POLICIES (Continued)

For the Year Ended 30th June, 2022

r) Inventories – IPSAS 12

Inventory is measured at cost upon initial recognition. To the extent that inventory was received through non-exchange transactions (for no cost or for a nominal cost), the cost of the inventory is its fair value at the date of acquisition.

After initial recognition, inventory is measured at the lower of cost and net realizable value. However, to the extent that a class of inventory is distributed or deployed at no charge or for a nominal charge, that class of inventory is measured at the lower of cost and current replacement cost.

Net realizable value is the estimated selling price in the ordinary course of operations, less the estimated costs of completion and the estimated costs necessary to make the sale, exchange, or distribution. Inventories are recognized as an expense when deployed for utilization or consumption in the ordinary course of operations of the Entity.

3. Adoption of New and Revised Standards

i) Relevant new standards and amendments to published standards effective for the year ended 30 June 2021.

Standard	Effective date and impact:
Standard: IPSAS 39: Employee Benefits	Applicable: 1st January 2018 The objective of IPSAS 39 was to create convergence to changes in IAS 19 Employee benefits. The IPSASB needed to create convergence of IPSAS 25 to the amendments done to IAS 19. It was intended to ensure accurate information relating to pension liabilities arising from the defined benefit scheme. Not applicable to IEBC. Pension scheme that is administered by trustees.

ii) New and amended standards and interpretations in issue but not yet effective in the year ended 30 June 2021.

Standard	Effective date and impact:
Standard: IPSAS 40: Public Sector Combinations	Applicable: Applicable: 1st January 2019 The standard covers public sector combinations arising from exchange transactions in which case they are treated similarly with IFRS 3-Business combinations and combinations arising from non-exchange transactions which are covered purely under Public Sector combinations as amalgamations. Not Applicable to IEBC.

NOTES TO THE FINANCIAL STATEMENTS

For the Year Ended 30th June, 2022

1. Transfers from Other Governments

Description	2021/2022	2020/2021
	Unaudited	Audited
Unconditional Grant	Shs 000	Shs 000
Operational Grant	19,530,010	4,920,449
Development Grant	111,635	70,880
Total	19,641,645	4,991,329

During the period under review, the Commission received one hundred and ten (110) all-in-one Hewlett Packard computer donations from International Foundation for Electoral Systems (IFES). The value of the donated computers at the balance sheet rate was Kshs.14,685,727.76 (USD 129,800.00). In compliance with IPSAS 23, the Commission discloses the economic benefits in the notes to the financial statements since the benefits were not received as actual transfers of cash but in kind.

2. Other Incomes

Description	2021/2022	2020/2021
	Unaudited	Audited
	Shs 000	Shs 000
Candidate Registration Fees	122,097	2,160
Proceeds from Disposal of Boarded items, Voter Registers & Maps	18,167	1,396
Costs Awarded in favour of the Commission (Court Awards)	3,200	-
Total	143,463	3,556

During the period under review, the Commission embarked on the auction and disposal of several boarded items, unserviceable motor vehicles and obsolete election materials and equipment.

The nomination fees received in the period were from the candidates cleared to contest in the by - elections.

In 2021/2022 financial year, the Commission has a budgeted target to collect Kshs.100 million in form of nomination fees from candidates interested in contesting in 2022 General Election. Actual nomination fees collected in 2021/2022 and 2016/2017 General Elections were Kshs.127.659 million and Kshs.107 million respectively.

NOTES TO THE FINANCIAL STATEMENTS (Continued)

For the Year Ended 30th June, 2022

3. Use of Goods and Services

Description	2021/2022	2020/2021
	Unaudited	Audited
	Shs 000	Shs 000
Utilities, Supplies & Services	13,155	12,079
Communications, Supplies & Services	395,009	53,365
Printing & Advertising	473,399	38,818
Rentals of Produced Assets	1,648,268	358,357
Training Expenses	333,574	99,695
Hospitality Supplies & Services	627,058	206,754
Insurance Costs	255,858	228,491
Specialized Materials & Supplies	3,388,061	53,812
Office & General Supplies & Services	46,679	52,818
Fuel, Oil & Lubricants	53,939	45,941
Bank Services, Commission & Charges	508	542
Contracted Guards	10,812	8,822
Membership Fees, Dues & Subscriptions	4,589	5,425
Legal Dues, Arbitration & Compensation	136,350	79,149
Contracted Professional services	86,873	1,080
Contracted Technical services	339,550	720
Witness Expenses	-	-
Parking Charges	7,266	11,071
Total	7,820,946	1,256,940

4. Employee Costs

Description	2021/2022	2020/2021
	Unaudited	Audited
	Shs 000	Shs 000
Salaries & Wages - Permanent Employees	1,281,323	1,128,398
Salaries & Wages - Contractual Employees	1,792,709	218,782
Personal Allowances -Payroll	1,143,619	986,223
Contributions to Pensions & Health Schemes	124,114	177,866
Domestic Travel & Subsistence	1,334,754	295,848
Foreign Travel & Subsistence	272,696	4,261
Gratuity Expense	15,274	17,594
Total	5,964,490	2,828,972

NOTES TO THE FINANCIAL STATEMENTS (Continued)

For the Year Ended 30th June, 2022

5. Commissioners Expense

Description	2021/2022	2020/2021
	Unaudited	Audited
	Shs 000	Shs 000
Travelling & Accommodation Expenses	24,823	5,235
Communication Expense	810	540
Club Membership Subscription.	406	1,307
Total	26,038	7,082

The Commissioners are paid facilitative allowances and mobile airtime as per the SRC rates and their employment contract. They draw their salaries from the Consolidated Fund administered by the National Treasury.

6. Depreciation and Amortization Expense

Description	2021/2022	2020/2021
	Unaudited	Audited
	Shs 000	Shs 000
Depreciation on Property, Plant & Equipment	1,012,095	628,902
Amortization on Intangible Assets	493,997	594
Total	1,506,092	629,496

7. Repairs & Maintenance Expenditure

Description	2021/2022	2020/2021
	Unaudited	Audited
	Shs 000	Shs 000
Routine Maintenance of Vehicles	39,249	14,926
Routine Maintenance of Other Assets	424,102	94,141
Total	463,351	109,067

NOTES TO THE FINANCIAL STATEMENTS (Continued)

For the Year Ended 30th June, 2022

8. Cash and Bank

Bank Account Information	2021/ 2022 Unaudited KSh 000	2020 / 2021 Audited KSh 000
KCB IEBC Mombasa A/c - 1116811162	2,512	121
KCB IEBC Kwale A/c - 1213387787	519	29
KCB IEBC Kilifi A/c - 1116804042	6,356	594
KCB IEBC Tana River A/c - 1213382645	2,645	9
KCB IEBC Lamu A/c - 1213649188	2	13
KCB IEBC Taita Taveta A/c - 1213372356	2,225	785
KCB IEBC Garissa A/c - 1116817365	52	9
KCB IEBC Wajir A/c - 1116539934	837	100
KCB IEBC Mandera A/c - 1116539934	685	60
KCB IEBC Marsabit A/c - 1212713311	2,255	13
KCB IEBC Isiolo A/c - 1116800543	4,419	1
KCB IEBC Meru A/c - 1116774127	76	9
KCB IEBC Tharaka Nithi A/c - 1213689465	28	8
KCB IEBC Embu A/c - 1213760690	39	11
KCB IEBC Kitui A/c - 1213362768	6	116
KCB IEBC Machakos A/c - 1116791366	10	617
KCB IEBC Makueni A/c - 1213508398	4	2,504
KCB IEBC Nyandarua A/c - 1213379695	31	1,935
KCB IEBC Nyeri A/c - 1116756439	2	6
KCB IEBC Kirinyaga A/c - 1213919738	3	309
KCB IEBC Murang'a A/c - 1213929717	39	6
KCB IEBC Kiambu A/c - 1116811553	32	1
KCB IEBC Turkana A/c - 1213415977	1,941	3
KCB IEBC West Pokot A/c - 1213417163	8	4
KCB IEBC Samburu A/c - 1214135293	47	6
KCB IEBC Trans Nzoia A/c - 1214152538	5	5
KCB IEBC Uasin Gishu A/c - 1116791110	9	5
KCB IEBC E.Marakwet A/c -1213364442	4	3
KCB IEBC Nandi A/c - 1213934052	8	2
KCB IEBC CEM Baringo A/c - 1213382173	5	11
KCB IEBC Laikipia A/c - 1213935350	4	5
KCB IEBC Nakuru A/c - 1116816857	4	18
KCB IEBC Narok A/c - 1213928338	360	3
KCB IEBC Kajiado A/c - 1213407435	2	16
KCB IEBC Kericho A/c - 1213840767	60	6
KCB IEBC Bomet A/c - 1116805243	89	6
KCB IEBC Kakamega A/c - 1116744694	14	6
KCB IEBC Vihiga A/c - 1213361087	5	4
KCB IEBC Bungoma A/c - 1116566443	1	559
KCB IEBC Busia A/c - 1213393167	1	1
KCB IEBC Siaya A/c - 1213697832	49	12
KCB IEBC Kisumu A/c - 1116780445	53	5
KCB IEBC Homa Bay A/c - 1214158560	168	47
KCB IEBC Migori A/c - 1213543320	1,587	70
KCB IEBC Kisii A/c - 1116811235	1,796	9,879
KCB IEBC Nyamira A/c - 1213365708	505	117
KCB IEBC Nairobi A/c - 1116817721	7	29
CBK IEBC Recurrent A/c - 1000181729	22,557	21,432
CBK IEBC Deposit A/c - 1000181931	53,392	43,909
CBK IEBC Development A/c - 1000182148	-	-
KCB IEBC University Way A/c - 1117602532	115,908	37,833
KCB IEBC US Dollar A/c - 1211876888	114	104
KCB IEBC Call A/c	10,000	10,000
KCB IEBC Salary Control A/c - 1126334723	18	163
CO-OP IEBC Recurrent A/c	366,268	-
Total	597,768	131,519

NOTES TO THE FINANCIAL STATEMENTS (Continued)

For the Year Ended 30th June, 2022

9. Receivables from Non-Exchange Transactions

Description	2021/2022	2020/2021
	Unaudited	Audited
	Shs 000	Shs 000
Outstanding Imprests	26,294	1,683
Salary Advances	167	796
Prepayments	10,000	9,097
Court Awarded Costs	5,396	5,396
Total	41,856	16,972

10. ECK Accounts Receivable

The uncleared old balances of Kshs 11,160,000 consists of Electoral Commission of Kenya staff salary advances and imprests that were outstanding at the time the defunct Electoral Commission of Kenya was disbanded in 2008.

The Commission has provided evidence to the National Treasury's Old Balances Taskforce that the amounts were recovered from the terminal dues and final salaries and wages to the Electoral Commission of Kenya staff.

11. ECK Car Loan Accounts Receivable

The former Ministry of Justice, National Cohesion & Constitutional Affairs recovered Kshs. 26,193,965.00 on account of car loan recoveries, Kshs. 11,160,000 on account of imprests/advances from the Commissioners and Staff of the defunct Electoral Commission of Kenya (ECK) and forwarded to the National Treasury after the disbandment of the ECK.

The Commission requested the Permanent Secretary to the National Treasury to refund the car loan recoveries and imprests/advances or authorize the Commission to write off the same from the books of accounts as per Section 69 (1)-(4) of the PFMA, 2012 and the PFMA 2012, Regulations. The Commission is yet to receive any feedback.

12. Inventory

Description	2021/2022	2020/2021
	Unaudited	Audited
	Shs 000	Shs 000
Inventory	907,560	-
Total	907,560	-

NOTES TO THE FINANCIAL STATEMENTS (Continued)

For the Year Ended 30th June, 2022

13. Property, Plant and Equipment Movement Schedule (Ksh.000)

DEPRECIATION RATES***	2.5%	30.0%	25.0%	12.5%	12.5%	
Note 13. Property, Plant and Equipment Schedule						
	Office Buildings	Computers &	Motor Vehicles	Office	Furniture and	Totals
	Kshs. '000	Kshs. '000	Kshs. '000	Kshs. '000	Kshs. '000	Kshs. '000
Cost:						
As at 30th June 2021	203,686	14,478,411	718,117	366,765	102,539	15,869,518
Additions	-	1,717,069	17,520	343,722	14,611	2,092,922
Buildings Under Construction (WIP)	122,177	-	-	-	-	122,177
Disposals	-	-	-	-	-	-
As at 30th June 2022	325,863	16,195,480	735,637	710,487	117,150	18,084,617
Depreciation:						
As at 30th June 2021	(22,129)	(13,116,576)	(660,374)	(242,653)	(64,435)	(14,106,167)
Acc. Dep. on Disposals	-	-	-	-	-	-
Charge for the Year	(4,539)	(923,671)	(18,816)	(58,479)	(6,589)	(1,012,095)
As at 30th June 2022	(26,668)	(14,040,247)	(679,190)	(301,132)	(71,025)	(15,118,262)
Net Carrying Amount:						
As at 30th June 2022	299,195	2,155,233	56,447	409,355	46,125	2,966,356
As at 30th June, 2021	181,557	1,361,835	57,743	124,112	38,104	1,763,351

During the period under review, the Commission received one hundred and ten (110) all-in-one Hewlett Packard computer donations from International Foundation for Electoral Systems (IFES). The value of the donated computers at the balance sheet rate was Kshs.14,685,727.76 (USD 129,800.00).

The Commission capitalized five (5) office buildings that were under construction as at 30th June 2022. No depreciation has been charged on buildings under construction. Full year depreciation has been charged for completed buildings in the year of completion.

14. Intangible Assets Movement Schedule

	2021/2022	2020/2021	2019/2020
	Kshs. '000	Kshs. '000	Kshs. '000
Cost:			
As at 1st July, 2021	66,871	66,871	66,871
Additions	1,645,272	-	-
As at 30th June 2022	1,712,143	66,871	66,871
Amortization:			
As at 1st July, 2021	(65,485)	(64,891)	(64,042)
Charge for the Year	(493,997)	(594)	(849)
As at 30th June 2022	(559,482)	(65,485)	(64,891)
Net Carrying Amount	1,152,660	1,386	1,980

The intangible assets consist of elections transmission and nominations system, exchange server systems, scanner software, antivirus software, research/SPSS software, accounting software and security access control systems.

NOTES TO THE FINANCIAL STATEMENTS (Continued)

For the Year Ended 30th June, 2022

15. Recurrent Accounts Payable

Description	2021/2022	2020/2021
	Unaudited	Audited
	Shs 000	Shs 000
Balance at the beginning of the year	2,299,626	3,124,814
Accruals in the Period	181,552	52,281
Accruals & Credit Notes Adjustments	-	(57,337)
Negotiation Savings	-	(138,996)
Accruals Settled in the Period	(429,611)	(681,136)
Total	2,051,567	2,299,626

16. Provision for Gratuity

The Commission operates an unfunded gratuity scheme for its contracted senior employees. The estimated amount for gratuities payable as at the end of the period is as shown below:

Description	2021/2022	2020/2021
	Unaudited	Audited
	Shs 000	Shs 000
Balance at the beginning of the year	19,330	33,755
Gratuity expense paid in the period	(3,000)	(32,019)
Accrued Gratuities in the year	15,274	17,594
Total	31,604	19,330

17. Refundable Deposits

Description	2021/2022	2020/2021
	Unaudited	Audited
	Shs 000	Shs 000
Balance at the beginning of the year	43,909	36,998
Retention Fees & Other Deposits Withheld	9,483	6,910
Retention Fees & Deposits Paid	-	-
Total	53,392	43,909

The retentions and deposits withheld includes monies retained by the Commission from construction companies who are yet to complete the construction works and other refundable deposits on hired ballot boxes, equipment and taxes.

NOTES TO THE FINANCIAL STATEMENTS (Continued)

For the Year Ended 30th June, 2022

18. Related Party Transactions

Entities and other parties related to the entity include those parties who have abilities to exercise control or exercise significant influence over its operating and financial decisions.

The Government of Kenya is the principal financier to the Commission's activities by way of exchequer releases.

During the period under review, the Commission had transactions detailed with related parties as follows:

Description	2021/2022	2020/2021
	Unaudited	Audited
	Shs 000	Shs 000
Salary Advances issued to staff at Zero Interest Rate	167	796
Transfers to Mortgage & Car Loan Scheme (HFC)	-	11,384
Unspent Balances returned to National Treasury	39,602	32,699
Total	39,769	44,879

19. Budget Information & Other Disclosures

The National Assembly approved the original budget for 2021/2022 financial year in June 2021 and the Commission was allocated Kshs. 22,940.591 million for the Recurrent Vote and Kshs.125 million under Development Vote.

The Commission's budget execution statement was prepared on a cash basis and informed by the actual income and expenditure as reflected in the IFMIS system.

The financial statements are prepared on accrual basis using a classification based on the nature of expenses in the statement of financial performance, whereas the budget is prepared on a cash basis. The amounts in the financial statements were adjusted from the cash basis to the accrual basis.

NOTES TO THE FINANCIAL STATEMENTS (Continued)

For the Year Ended 30th June, 2022

The material variances in the budget execution statement can be explained as follows:

a) Significant Savings/Unutilized budget of Kshs.3.48 Billion.

There was significant unutilized budget of Kshs.3.48 billion. This was because of the reduction of polling stations from the initial planned 53,300 to 46,229 polling stations. Polling stations are determined by the actual number of voters who register before an election and has a relationship with quantity of election materials, human resources and services required.

b) AIA Collections (149%)

Appropriation in aid earned by the Commission as at 30th June, 2022 was mainly from nomination fees/ candidate registration fees received ahead of the August General Elections.

The amounts of appropriation-in-aid (AIA) receivable is largely dependent on the number of candidates seeking elective posts and number of elections held in a period.

c) Routine Maintenance for Boundaries Activities –8%

Most of routine maintenance procurement processes had not been concluded as at 30th June, 2022.

20. Contingent Assets

IPSAS 19 prescribes the accounting treatment for provisions, contingent liabilities and contingent assets and defines their identification and recognition.

During the financial year, the Commission issued letters of credit to acquire additional KIEMs and associated software and ballot papers whose deliveries and contract closure were expected to be concluded in the subsequent financial year. Consequently, the Letters of Credit were secured by use cash collateral and the values of cash collateral were as tabulated below:

Cash Collateral Account	Event	Amount	Forex Rate as at 30.6.2022	Amount (Kshs.)
Co-op Bank Collateral Account .University Way Branch.	Supply and delivery of KIEMs Kits and Associated software & accessories.	UDS 7,445,346.9	117.8324	877,303,094.06
KCB Bank Collateral Account .University Way Branch.	Supply and Delivery of Ballot papers.	EUR 2,560,023.2	124.0203	317,494,845.27
Total Value of Contingent Asset				1,194,797,939.33

During the previous financial years, the Commission was awarded costs amounting to Kshs.59.854 million (taxed costs) and Kshs. 205.060 million (capped costs). However, collection of capped costs requires taxation before determination of actual amount collectable. Further, indigent litigants acting as surrogates for politicians out to cushion themselves against award of costs filed some petitions.

NOTES TO THE FINANCIAL STATEMENTS (Continued)

For the Year Ended 30th June, 2022

21. Contingent Liabilities

IPSAS 19 prescribes the accounting treatment for provisions, contingent liabilities and contingent assets and defines their identification and recognition.

The Commission has been sued in various cases with the potential exposure of at least Kshs. 157.351 million to pay various general election pending bills, which have not been validated, by the National Treasury's internal audit department or have pending court cases. The Commission is a defendant or co-defendant in various election petition litigations and claims. The outcomes of these litigations and claims are yet to be determined.

During the financial year, the Commission entered into a contractual arrangement or commitment to acquire additional KIEMs and associated software and ballot papers whose deliveries and contract closures were expected to be concluded in the subsequent financial year. The value of contingent liability as at the reporting date is as tabulated below:

Firm Name	Event	Amount	Forex Rate as at 30.6.2022	Amount (Kshs.)
Smartmatic International Holding B.V.	Supply and delivery of KIEMs Kits and Associated software & accessories.	UDS 7,445,346.9	117.8324	877,303,094.06
Inform Hellas	Supply and Delivery of Ballot papers.	EUR 2,560,023.2	124.0203	317,494,845.27
Total value of Contingent Liability				1,194,797,939.33

22. Employee Benefits: Defined Contribution Scheme

IPSAS 25 prescribes the accounting and disclosure requirements for employee benefits and establishes the matching principle that the cost of the employee benefits should be recognized in the period in which the employee provides the services to the entity and not when they are paid or become payable.

The Commission runs a defined contribution pension scheme. The assets of the scheme are held in a separate trustee administered fund, which is funded by contributions from both the Commission as the employer at 15% and employees at 7.5% of basic salary. The scheme is currently managed by ICEA Lion Asset Management.

The Commission's contributions to the above scheme are charged to the income and expenditure account in the period to which they relate.

The main purpose of the scheme is the provision of retirement benefits for members upon retirement from the founder's service and relief for the dependants of deceased members.

NOTES TO THE FINANCIAL STATEMENTS (Continued)

For the Year Ended 30th June, 2022

The latest fund financial position and performance is as summarized below:

Statement of Changes in Net Assets Available for Benefits	2021/2022	2020/2021
	Unaudited	Audited
Description	Shs 000	Shs 000
Net Assets available for Benefits at the Start of Year	3,216,487	2,564,668
Income from dealings with Members	275,420	276,263
Benefits Payable to Seceding Members	(81,462)	(32,244)
Net Returns on Investments	8,472	419,298
Administrative Expenses	(11,926)	(11,497)
Net Assets available for Benefits at the End of Year	3,406,991	3,216,487

23. Number of Employees

The average number of permanent and pensionable employees for the Commission as at 30th June, 2022 and 30th June, 2021 stood at nine hundred and fourteen (914) and eight hundred and forty (846) respectively.

The Commission however engages contractual staff on a need basis.

Gender distribution is 35% female and 65% male, while the ethnic representation within the Commission is forty-three (43) ethnic tribes out the forty-six (46) existing ethnic communities.

Description	2021/2022	2020/2021
	Unaudited	Audited
No. of Permanent & Pensionable Staff	914.00	846
Total	914.00	846

24. Entity Tax Status

The Commission is a government agency, fully funded by the government and is therefore tax exempt. The Commission pays taxes as per the regulations.

25. Subsequent Events

The Commission is not aware of any matter or circumstances arising after the end of the financial year, not otherwise dealt with in the financial statements, which would significantly affect the financial position and the results of its operations as laid out in these financial statements.

ANNEXURES TO THE FINANCIAL STATEMENTS

Appendix I: Implementation Status of Auditor General's Recommendations

The following is the summary of issues raised by the external auditor, and management comments that were provided to the auditor.

REFERENCE NO. ON EXTERNAL AUDIT REPORT	ISSUE / OBSERVATION FROM AUDITOR	MANAGEMENT COMMENTS	FOCAL POINT PERSON TO RESOLVE THE ISSUE.	STATUS	TIME FRAME
Auditor General Report of October 2018 for the Financial Year 2016/2017.	1.6 Purchase of Kenya Integrated Election Management Systems (KIEMS) Kit.	1. Matter does not fall under Commission's purview.	DICT	Unresolved	2019/2020
		2. A verification exercise has been done.	DICT	Unresolved	
		3. The Commission has been allocated funds and has planned for support and maintenance of the KIEMS to ensure re-usability of the technology in future.	DICT		
		4. The Commission has put in place accounting and financial controls and procurement systems to enhance compliance with the Public	CEO	Unresolved	
		5. Procurement and Assets Disposal Act as well as the circulars issued by the Public Procurement Regulatory Authority.	DICT		
Auditor General Report of October 2018 for the Financial Year 2016/2017.	2.0 Supply, Delivery, Implementation, and Commissioning of Network Examination of Payment Vouchers (a) Mismanagement of 553 Thuraya Modems and SIM Cards Loaded with Data Transmission.	1. Matter does not fall under Commission's purview. (Office of the Auditor General)	DICT	Unresolved	2019/2020
		2. The Commission has planned to request Communication Authority to provide the Current and future network coverage and plan to ensure 100% transmission of result.	DICT	Unresolved	2019/2020
		3. The satellite modems still remains backup option in areas where there is no coverage and in critical transmission tallying centers	DICT	Unresolved	2019/2020
	(b) Procurement of additional 1,000 Thuraya SIM Cards Loaded with Data.	The Commission has put in place accounting and financial controls and procurement and inventory systems to facilitate timely reconciliations and enhance compliance with the stipulated laws and regulations.	DICT	Unresolved	2019/2020
	(c) Undelivered SIM Cards from Another Firm	The Commission has put in place accounting and financial controls and procurement and inventory systems to facilitate timely reconciliations and enhance compliance with the stipulated laws and regulations.	DICT	Unresolved	2019/2020

Auditor General Report of October 2018 for the Financial Year 2016/2017.	2.2 Management of 1,000 Thuraya Modems and Sim Cards Loaded with Data	For future elections, the Commission shall make an appeal to the Communication Authority in ensuring that the MNOs appreciate that elections are activities of national importance and therefore their services and charges in regard to elections should not be at commercial rates.	DICT	Unresolved	2019/2020
		The rates should be based on actual consumption. This will be enforced during contracting in accordance with the PPDA	DICT	Unresolved	2019/2020
Auditor General Report of October 2018 for the Financial Year 2016/2017.	2.3 Failure to Provide Payment Vouchers and Other Documents.	For future elections, the Commission shall make an appeal to the Communication Authority in ensuring that the MNOs appreciate that elections are activities of national importance and therefore their services and charges in regard to elections should not be at commercial rates.	DICT	Unresolved	2019/2020
		Record management has been improved and documentation done at all times.			2019/2020
Auditor General Report of October 2018 for the Financial Year 2016/2017.	3.1 Procurement of data centres and back up infrastructure (cloud services).	The Commission undertook an audit of all pending bills and submitted an Internal Audit Report to National on November 2018 for funding.	DICT	Unresolved	2019/2020
Auditor General Report of October 2018 for the Financial Year 2016/2017.	3.2 Change of Mode of Result Transmission Infrastructure	Matter does not fall under Commission's purview. (Office of the Auditor General)	DICT	Unresolved	2019/2020
Auditor General Report of October 2018 for the Financial Year 2016/2017.	4. Purchase of Oracle Database and Security Solution.	The Commission has put in place accounting and financial controls, systems and standards to enhance compliance with the stipulated laws and regulations.	CEO	Unresolved	2019/2020
Auditor General Report of October 2018 for the Financial Year 2016/2017.	5. Procurement of Co-location Services for Data Centre and Disaster Recovery Site.	This was a security solution /systems or software and services procured based on a needs analysis for the operation of the commission. Includes the conduct of the election and therefore it is still required, the system is in use, part of the solution included the support and Maintenance of the BVR IBM Servers – SLA, for which the Communication requested for funds and has been allocated to procure an SLA in the FY2019/2020.	DICT	Unresolved	2019/2020
Auditor General Report of October 2018 for the Financial Year 2016/2017.	6. Supply and Delivery of Ballot Papers for Elections, Statutory Declaration Forms and The Register of Voters.	The Commission has so far made recoveries worth Kshs. 150,501.71 USD in form of swift transfers.	DICT	Unresolved.	2019/2020
		The Commission has instituted a recovery process for the balance of Kshs.4, 981,474.00.	DICT	Unresolved.	2019/2020
Auditor General Report of	7. Supply and Delivery of Ballot	The Commission has already complied with establishment of	DICT	Unresolved.	2019/2020

October 2018 for the Financial Year 2016/2017.	Boxes for the General Elections.	framework contracts. This exercise is a continuous process.			
Auditor General Report of October 2018 for the Financial Year 2016/2017.	8. Supply and delivery of badges. Audit Findings	The Commission carries out market surveys for procurements to ensure competitiveness and value for money.	CEO	Unresolved.	2019/2020
	(a) Alteration of Contract Price Schedule	The commission has enhanced the capacity of the SCMD to facilitate continuous compliance.	DSCM		2019/2020
	(b) Variation of Contract Price.	The Commission has put in place accounting and financial controls and procurement and inventory systems to facilitate timely reconciliations and enhance compliance with the stipulated laws and regulations.	DSCM	Unresolved.	2019/2020
	(c) Delivery Costs	The Commission has engaged the vendor on negotiations to recover the extra cost of transport not incurred by the vendor.	DSCM	Unresolved.	2019/2020
		The Commission has put mechanisms in place to ensure that contracts are tied to specifications.	DSCM	Unresolved.	2019/2020
Auditor General Report of October 2018 for the Financial Year 2016/2017.	9. Supply of gas lamp mantles (i) Irregular Award of Contract.	The Commission has put in place accounting and financial controls, systems, standards to enhance compliance with the stipulated laws and regulations.	DSCM	Unresolved.	2019/2020
	(ii) Direct Procurement	The Commission has put in place accounting and financial controls and procurement and inventory systems to facilitate timely reconciliations and enhance compliance with the stipulated laws and regulations.	DSCM	Unresolved	2019/2020
Auditor General Report of October 2018 for the Financial Year 2016/2017.	10. Supply and delivery of Security Seals	The Commission has put in place accounting and financial controls and procurement and inventory systems to facilitate timely reconciliations and enhance compliance with the stipulated laws and regulations.	DSCM	Unresolved	2019/2020
Auditor General Report of October 2018 for the Financial Year 2016/2017.	11. Supply, Delivery, Installation and Commissioning of Wide Area.	The Commission has put in place accounting and financial controls, systems, standards to enhance compliance with the stipulated laws and regulations.	DICT	Unresolved.	2019/2020
	Network in Two Hundred and Ninety (290) New Locations, Eighteen (18) Existing Sites.	The Commission has appointed a new director supply chain management (DSCM).	DICT	Unresolved.	2019/2020
	Provision of Dedicated Internet Services.	The Commission is also enhancing capacity of the procurement function to enhance compliance	DICT	Unresolved.	2019/2020
Auditor General Report of October 2018 for the Financial Year 2016/2017.	12. Irregular procurement of transport services.	The Commission has put in place accounting and financial controls, systems, standards to enhance compliance with the stipulated laws and regulations.	DSCM	Unresolved.	2019/2020

		The Commission has appointed a new director supply chain management (DSCM).	DSCM	Unresolved.	2019/2020
		The Commission is also enhancing capacity of the procurement function to enhance compliance.	DSCM	Unresolved.	2019/2020
Auditor General Report of October 2018 for the Financial Year 2016/2017.	13. Supply of BVR kit internal batteries.	The batteries are in good and usable state are continuously being used for the maintenance of the BVR Kits and to support the CVR activities that are ongoing in the field.	DSCM	Unresolved	2019/2020
		The batteries are continuously being used for the maintenance of the BVR Kits and to support the CVR activities that are ongoing in the field.	DSCM	Unresolved	2019/2020
Auditor General Report of October 2018 for the Financial Year 2016/2017.	14. Provision of Strategic Communication and Integrated Media Campaign Consultancy Services.	The Commission has conducted status and situation analysis.	DVEP	Unresolved.	2019/2020
	(i). Award of the contract	The Commission is in the process of developing the strategic media campaign manual.	DVEP	Unresolved.	2019/2020
	(ii). Payment before confirmation of Delivery of Services.	The manual will be tabled upon finalization. The Commission undertook an audit of all pending bills and submitted an Internal Audit Report to National on November 2018.	DVEP	Unresolved.	2019/2020
Auditor General Report of October 2018 for the Financial Year 2016/2017.	15. Unauthorized Notification of Awarded Contracts.	The Commission has put in place mechanisms to ensure that only the Accounting Officer notifies the successful and unsuccessful bidders on the awards.	DSCM	Unresolved	2019/2020
Auditor General Report of October 2018 for the Financial Year 2016/2017.	16. Failure to Provide Performance Security.	The Commission has put in place accounting and financial controls, systems, standards to enhance compliance with the stipulated laws and regulations.	DSCM	Unresolved.	2019/2020
Auditor General Report of October 2018 for the Financial Year 2016/2017.	17. Undisclosed Court Awards to the Commission.	The detailed report on the recovery of costs has been prepared.	DLPA	Unresolved.	2019/2020
Auditor General Report of 23 rd May 2016.	Irregular Procurement and payment of Additional 4600 Electronic Voter Identification Devices (EVIDs).	The payment of the handheld EVIDs were procured within the law and payment were based on subsisting contract between the parties and not the subject of variation	CEO	Matter in court.	2019/2020
Auditor General Report of 23 rd May 2016.	Irregular Payment for transportation of Election Materials.	Mr. Abdullah Yusuf Farah swore an affidavit claiming that he was also the owner of the Alhamdul Company. The Commission is streamlining its records management system.	CEO	Not within the purview of the Commission.	2019/2020

Auditor General Report of 23 rd May 2016.	Irregular procurement of election materials due to lack of approved procurement plan for the year.	The priorities were in the procurement plan. The procurement plan was available for review.	CEO	Unresolved	2019/2020
Auditor General Report of March 2017.	Irregular Payment of Legal Dues, Arbitration & Compensation.	The additional pending bills paid were paid with due approvals and adequately support based on ARO.	DLPA	Unresolved	2019/2020
Auditor General Report of March 2017.	Use of Law Firms that were not Prequalified.	The Commission has used the prequalification lists of other public entities as is permissible under section 32 of the now repealed Public Procurement and Disposal Act, 2005.	DLPA	Unresolved	2019/2020
Auditor General Report of March 2017.	Legal Representation without valid contracts.	Letter of instructions duly signed based on the ARO.	DLPA	Unresolved	2019/2020
Auditor General Report of March 2017.	Procurement of air tickets totaling to Kshs.9,247,782.00 through direct procurement contrary to Section 74 (3) of the Public Procurement and Disposal Act, 2005.	The tickets were procured directly from vendors who are registered by I.A.T.A.	DSCM	Unresolved	2019/2020
Auditor General Report of 2018	Irregular Procurement of Catering Services.	The rates were determined through competitive tendering processes that resulted in various rates being awarded to different suppliers in various counties where award was based on the lowest evaluated bidder.	CEM	Unresolved	2019/2020
Auditor General Report for 2018/2019 & 2019/2020 financial years.	Property, Plant and Equipment: not included in the financial statements. No register of lands and buildings.	Some of the parcels of land and buildings inherited from the defunct Electoral Commission of Kenya had no ownership and their value could not be ascertained due to lack of official hand over documents from the defunct Electoral Commission of Kenya.	AO	Unresolved	2019/2020

Auditor General Report for 2018/2019 & 2019/2020 financial years.	Inventories: the value of these inventories was not determined and disclosed in the financial statements.	The Commission has embarked on an elaborate disposal process that will culminate in the determination of the value of the inventory in the Commission warehouses.	DSCM	Resolved	2022/2023
Auditor General Report for 2018/2019 & 2019/2020 financial years.	Contingent Liability: Failure to factor in possible future obligations relating to legal fees on the pending court cases and claims in the financial statements.	It would not be possible to have a realistic estimate of the probable cost since the costs are determined upon conclusion of the cases. The Commission is of the view that the costs are reasonably ascertained when judgements are made.	DF	Resolved	2022/2023
Auditor General Report for 2018/2019 & 2019/2020 financial years.	Account Payables: failure to settle bills during the year to which they relate distorts the financial statements for the year, and adversely affects the provisions for the subsequent year to which they have to be charged.	The pending bills were accrued due to lack of exchequer for payments, which had been planned for and processed up to the Internet Banking level The Commission has made several efforts to secure the budgetary provision to facilitate settlement of the said bills in addition to settling them as first charge.	AO	Unresolved	
Auditor General Report for 2018/2019 & 2019/2020 financial years.	Uncollected Revenue: No satisfactory explanation has been provided for failure to collect promptly the taxed costs and for the delay in taxation of the capped costs.	Hampered by taxation in court which takes long. Recovery of costs is dependent on successful securing of certificates from taxing officers in Court followed by appropriate execution proceedings.	DLPA	Unresolved	2022/2023

<p>Auditor General Report for 2019/2020 Financial Year.</p>	<p>ECK Accounts Receivable:</p> <p>Amount of Kshs.11, 160,000 and Kshs.26,193,000 have been outstanding for more than ten (10) years.</p>	<p>The amounts relate to Imprest or salary advances and car loans respectively held by staff of the defunct Electoral Commission of Kenya. The funds were recovered from the final dues of the staff and former commissioners by the National Treasury but were not remitted to the Commission. The Commission is engaging the National Treasury with a view of getting the money refunded or obtaining an approval to write it off from the Commission books of accounts.</p>	<p>DHRA</p>	<p>Unresolved</p>	<p>2022/2023</p>
---	--	--	-------------	-------------------	------------------



.....
Marjan H. Marjan
ICPAK M/No. 2786
Commission Secretary

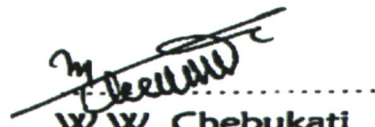

.....
W.W. Chebukati
Chairperson

Appendix II: Projects Implemented by IEBC

The following Projects were implemented by the Commission and were fully funded by the Government of Kenya under the development budget.

No.	Project name	Project Contract sum (Kshs)	Total Spent to Date (Kshs):	Completion Percentage to Date:	Budget (Kshs)	Actual (Kshs)	Source of Funds
1	Proposed construction of Warehouse for IEBC Isiolo County	37,106,200.00	37,106,200.00*	100%	40,000,000.00	37,106,200.00	GOK Development
2	Proposed Construction of Wajir County Multipurpose Warehouse and Perimeter Wall	49,500,079.00	40,000,000.00	81%	40,000,000.00	49,500,079.00	GOK Development
3	Proposed Construction of IEBC Kakamega County Warehouse	42,783,208.00	42,783,208.00*	100%	40,000,000.00	42,783,208.00	GOK Development
4	Proposed Construction of Warehouse for IEBC Machakos County.	35,843,260.00	35,843,260.00 *	100%	40,000,000.00	35,843,260.00	GOK Development
5	Proposed construction of IEBC Garissa County multipurpose warehouse	40,503,511.20	40,503,511.20*	100%	40,000,000.00	40,503,511.20	GOK Development
TOTAL					200,000,000.00	205,736,258.20	

*Funding for the projects was done in June,2022 and the contractors were doing final touches on the projects as at 30th June,2022.

Appendix III: Transfers from & to Other Government Entities

ACTUAL TRANSFERS TO & RECEIPTS FROM OTHER GOVERNMENT ENTITIES IN 2021/2022FY							
Name of the MDA transferring funds to & from IEBC	Date as per CBK Bank Statement	Nature: Recurrent/Development/ Others	Amount (Kshs).	Statement of Financial Performance (Kshs).	Where recorded/recognized		
					Exchequer /Government Grant (Kshs).	Statement of Changes in Net Assets (Kshs).	Total Transfers (Kshs).
National Treasury Exchequer Dept.	23-Jul-21	Recurrent Vote (2020/2022fy IEBC Closing CBK Recurrent Balance Recovery by National Treasury).	(21,965,063.95)	-	(21,965,063.95)		(21,965,063.95)
National Treasury Exchequer Dept.	9-Dec-21	Recurrent Vote (2020/2022fy IEBC Closing CBK Recurrent Balance Recovery by National Treasury).	(17,637,310.05)	-	(17,637,310.05)		(17,637,310.05)
TOTAL FUNDS TRANSFERRED TO N.T							
IEBC	Various Dates	2021/2022FY Recurrent Exchequer Funding.	19,530,010,242.05	19,530,010,242.05	-	19,530,010,242.05	19,530,010,242.05
IEBC	Various Dates	2021/2022FY Recurrent Exchequer Funding.	111,635,119.20	111,635,119.20	-	111,635,119.20	111,635,119.20
TOTAL FUNDS TRANSFERRED TO IEBC BY N. TREASURY							
			19,641,645,361.25	19,641,645,361.25	(79,204,748.00)	19,641,645,361.25	19,562,440,613.25



INDEPENDENT ELECTORAL AND BOUNDARIES COMMISSION

**IEBC STAFF MORTGAGE AND CAR LOAN SCHEME
ANNUAL FINANCIAL STATEMENTS
FOR THE YEAR ENDED 30TH JUNE, 2022.**

Prepared in accordance with the Accrual Basis of Accounting Method under the International Public Sector Accounting Standards (IPSAS)

KEY COMMISSION INFORMATION AND MANAGEMENT

1. Background information

The Independent Electoral and Boundaries Commission is a Constitutional body established under Article 88 of the Constitution of Kenya and is a body corporate pursuant to Article 253 of the Constitution of Kenya. As per Article 88 of the Constitution of Kenya 2010, the Commission is responsible for conducting or supervising referenda and elections to any elective body or office established by the constitution, and any other elections as prescribed by an Act of Parliament. Article 88 and IEBC Act 2011 further enumerate the mandate of the Commission to include, inter alia, continuous registration of voters, revision of the voter's roll; delimitation of constituencies and wards boundaries; regulation of political parties process; development of a code of conduct for candidates and parties and monitoring of compliance with legislation on nomination of candidates by parties.

2. General Information

The IEBC Mortgage and Car Loan Scheme was set up in March, 2017 as per the powers conferred by Sections 18, 19 and 31 of the Independent Electoral and Boundaries Commission Act, 2011 and pursuant to the Salaries and Remuneration Commission Circular No SRC/ADM/CIR/1/13 Vol. III (128) of 17th December, 2014 on Car Loan and Mortgage Schemes for State officers and other Public Officers of Government of Kenya.

The financial year of the scheme is a period of twelve months ending on 30th June each year.

The Commission is mandated to submit its annual financial statements to the Auditor General by 30th September 2022 and a copy of the statements to the Controller of Budget, the National Treasury and the Commission of Revenue Allocation within the statutory timelines as stipulated in Section 81 of the Public Finance Management Act, 2012.

3. Key Management

The Commission's day-to-day activities are run by the Secretariat. The secretariat's management team was as follows:

- | | |
|---------------------------|--|
| (a) Marjan H. Marjan | Commission Secretary/CEO. |
| (b) Ruth Kulundu | Deputy Commission Secretary –Operations. |
| (c) Obadiah Keitany | Deputy Commission Secretary –Support Services. |
| (d) Osman H. Ibrahim | Director Finance. |
| (e) | Lorna Agnes Onyango Director Human Resources
and Administration. |
| (f) Rasi Masudi | Director Voter Education and Partnerships. |
| (g) Dr. Catherine Kamindo | Director Research, Electoral Boundaries and Risk
Management. |
| (h) Michael Ouma | Director Information and Communication Technology. |
| (i) Moses Sunkuli | Ag. Director Voter Registration and Elections Operations. |
| (j) Chrispine Owiye | Director Legal Affairs and Public Affairs. |
| (k) Reuben K. Chirchir | Ag. Director Audit Risk and Compliance. |
| (l) Harley K. Mutisya | Director Supply Chain Management. |

KEY COMMISSION INFORMATION AND MANAGEMENT

4. Fiduciary Management

The key management personnel who held office during the 2021/2022 financial period ending 30th June, 2022 and had direct fiduciary responsibility were:

No.	Designation	Name
1.	Commission Secretary/CEO	Marjan H. Marjan.
2.	Deputy Commission Secretary - Operations	Ruth Kulundu.
3.	Deputy Commission Secretary - Support Services	Obadiah K. Keitany.
4.	Director Finance	Osman H. Ibrahim.
4.	Director Supply Chain Management	Harley K. Mutisya.
5.	Ag. Director Audit Risk & Compliance	Reuben K. Chirchir
6.	Director Human Resources & Administration	Lorna A. Onyango.
7.	Director Information & Communication Technology	Michael Ouma.
8.	Ag. Director Voter Registration & Elections Operations	Moses Sunkuli
9.	Director Research, Electoral Boundaries & Risk Management.	Dr. Catherine Kamindo.
10	Director Voter Education & Partnerships	Rasi M. Masudi.
11.	Director Legal Affairs & Public Affairs	Chrispine Owiye.

5. Commission Bankers

Central Bank of Kenya
Haille Sellasie Avenue
P.O. Box 60000-00200
NAIROBI.

Housing Finance Company
Rehani House, Kenyatta Avenue
P.O. Box 30088 - 00100
Nairobi, Kenya.

6. Commission Auditors

The Auditor General
Kenya National Audit Office
Anniversary Towers
P.O. Box 30084- 00100
NAIROBI.

7. Commission Headquarters

The Independent Electoral and Boundaries Commission
Anniversary Towers, 6th Floor,
P.O Box 45371-00100
NAIROBI.

8. Principal Legal Advisor

The Attorney General
State Law Office
Harambee Avenue
P.O. Box 40112-00200
NAIROBI.

THE IEBC COMMISSION

Chairperson: Mr. Wafula W. Chebukati

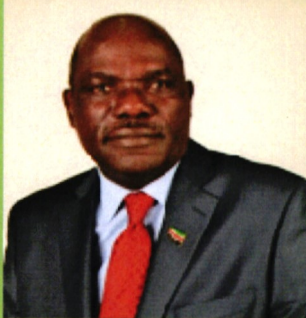

Key Qualifications:

- Master of Business Administration from Jomo Kenyatta University of Agriculture and Technology.
- Bachelor of Law Degree from the University of Nairobi.
- Post Graduate Diploma from the Kenya School of Law.
- Advocate of the High Court of Kenya.

Experience:

- Over 32 years' experience in legal practice specializing in litigation and dispute resolution, conveyancing, labour laws, company mergers and acquisitions, Maritime and treaties.
- Works on a full-time basis as a chairperson of the Commission.
- Chairs the Dispute Resolution Committee and the Electoral Code of Conduct Committee.

Vice Chairperson: Ms. Juliana Whonge Cherera



Key Qualifications:

- Master of Education, Leadership and Educational Management from Kenya Methodist University.
- Bachelor of Education (Arts). Honours from Kenyatta University.
- Dip. Project Management; KIM.
- Dip. Early Childhood Development Education (ECDE); KNEC.
- Strategic Leadership and Development Program; KSG.
- Senior Management Course (SMC); KSG.

Experience:

- Ms Cherera Has over 18 years' experience in Education and Management in the public sector.
- Before her appointment to the Commission, she worked as Chief Officer Executive in the Strategic Delivery Unit of the Mombasa County Government.
- Member of Mombasa County Emergency Household Relief and Nutrition Support Project Coordination Committee.
- Secretary to the Mombasa County Economic Recovery and Legacy Strategy.
- Member of Kenya Devolution Support Program Committee.
- Works on a full-time basis as a vice chairperson of the Commission.

- She Chairs the Voter Education, Partnerships and Stakeholders Engagement Committee.

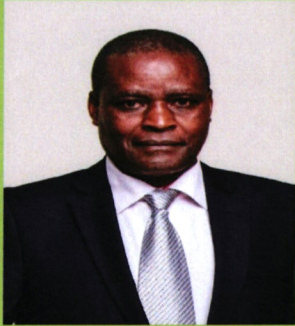

Commissioner: Francis M. Wanderi

Key Qualifications:

- Master of Science in Management (MSc. Mgmt.); from Arthur D. Little Management Institute at Boston, USA.
- Bachelor of Education; UoN.
- Transformative Leadership and Change Management.
- Corporate Governance Course by Commonwealth Association for Corporate Governance.

Experience:

- Over 32 years in senior management within public and private institutions characterized by integrity and a high performance, and with a proven record of accomplishment in development and execution of strategy, people and change management and, leadership and innovation toward realization of organizational objectives and visions.
- Mr. Francis M. Wanderi is a former Chairperson of EPZ and director Roots Credit Ltd.
- He Chairs Finance and Supply Chain Management Committee.

Commissioner: Irene Cherop Masit



Key Qualifications:

- Master's degree in Strategic Human Resource Management from the University of Manchester, UK.
- Bachelor of Law degree - University of Nairobi.
- Bachelor of Arts degree in Social work -University of Nairobi.
- Post Graduate Dip from Kenya School of Law.
- Member of International Certified Addiction Professional (ICAP I-Treatment; Colombo Plan Global Centre for Credentialing and Certification.
- Member of Institute of Internal Auditors (IIA).
- Advocate of the High Court of Kenya.

Experience:

- Ms. Irene Masit has over 25 years work experience and knowledge in Government and Non – Governmental Organizations.
- She is the immediate former board member, National Government Constituency Development Fund (NGCDF).
- She has knowledge and experience in Finance, Governance, Management and Public Administration.
- Chairs the Legal, Compliance and Political Party Liaison Committee and the Leadership and Integrity Committee.



Commissioner: Prof. Abdi Yakub Guliye

Key Qualifications:

- PhD in Animal Nutrition from Rowett Research Institute/ University of Aberdeen, Scotland, UK.
- Master of Science in Animal Production from University of Aberdeen, Scotland, UK.
- Bachelor of Science in Animal Production from Egerton University.

Experience:

- Prof. Guliye has over 28 years of university teaching experience, of which in the last 7 years he had additional administrative/ managerial roles. He also served in various Boards of Institutions/Organizations, having chaired committees such as Audit and Risk Management as well as Finance.
- Chairs the Election Operations, Research and Boundary Delimitation Committee.



Commissioner: Mr. Justus Nyang'aya

Key Qualifications:

- Master of Arts (M.A) Education from the Institute of Education, University of London (IOE), UK.
- Diploma in Leadership, Governance, Peace and Conflict Transformation from the United Nations' University -International Leadership Academy in Jordan -Amman.
- He studied educational science in Kenya and Great Britain.

Experience:

- Mr. Nyang'aya has over 32 years of experience in Strategic Leadership, Governance and Social Accountability Organizations.
- He was director of Lead Africa, an organisation working for the Qualification of African Managers.
- Former Country Director, Amnesty International Kenya. Amnesty Kenya's work concentrates on the prevention of forced evictions, the protection of housing rights and women's rights.
- He also worked for the Netherlands Development Organisation as well as UNESCO.
- Chairs the Information and Communication Technology Committee.

Commissioner: Mr. Boya Molu



Key Qualifications:

- Master's in Business Administration (HR Management Option), Periyar University, India.
- Bachelor of Business Administration from Karnatak University, India.
- Higher National Diploma in Human Resources Management (KNEC), IHRM Kenya.

Experience:

- Has over 16 years' experience in Human Resource Management and administration mainly in public sector.
- Prior to joining the Commission Mr. Molu served in various capacities at the Central Bank of Kenya (CBK) and the Judiciary in Human Resource and Administration Directorate.
- Also served as a council member of the Institute of Human Resources Management (IHRM) Kenya.
- Chairs the Human Resource, Administration and Training Committee.

THE IEBC MANAGEMENT TEAM



Name: CPA Marjan H. Marjan

CEO/Commission Secretary

Profession/Qualifications:

- MBA in Strategic Management - University of Nairobi (UoN);
- BCom (Accounting Option) - (UoN);
- Certified Public Accountant (CPA-K);
- Certified Information Systems Auditor (CISA);
- Certified Internal Auditor (CIA);
- Certification in Control Self-Assessment (CCSA)
- Certified Quality Assessor (CQA);
- Practicing Member of ICPAK in good standing;
- Member of Information Systems Audit & Control Association (ISACA);
- Member of Institute Internal Auditor (IIA).



Name: Ruth Kulundu

Deputy CEO/Deputy Commission Secretary - Operations

Profession/Qualifications:

- MBA –Strategic Management - (UON);
- Bachelor of Commerce BCOM - (UoN);
- Associate of Chartered Insurance Institute - ACII (London);
- Associate of Chartered Insurance Institute - AIIC (Kenya);
- Associate of Chartered Institute of Arbitrators (Kenya Chapter);



Name: CPA Obadiah K. Keitany

Deputy CEO/ Deputy Commission Secretary – Support Services

Profession/Qualifications:

- MBA Finance – University of Nairobi (UoN);
- BCom Insurance (UoN);
- Certified Public Accountant (CPA-K);
- Certified Internal Auditor (CIA);
- Certified Information Systems Auditor (CISA);
- Certified Public Secretary (CPS-K);
- Certified Quality Assessor (CQA);
- Post Graduate Diploma in Corporate Governance (KCA);
- Member of ICPAK in good standing;
- Member of Information Systems Audit & Control Association (ISACA);
- Member of Institute of Internal Auditors (IIA);
- Member of Institute of Certified Secretaries of Kenya.



Name: CPA Osman H. Ibrahim

Director Finance

Profession/Qualifications:

- Master's in business administration in Finance (MBA);
- Bachelor of Commerce from the University of Nairobi;
- Certified Public Accountant (CPA-K);
- Member of ICPAK in good standing;
- Member of IIA –Kenya in good standing;



Name: Chrispine Owiye

Director Legal and Public Affairs.

Profession/Qualifications:

- Master of Law in Law Governance and Democracy -University of Nairobi;
- Bachelor of Law degree (LLB) – Moi University;
- Post Graduate Diploma in Legal Education (Kenya School of Law);
- Certificate in Prosecution (CID Training School);
- Advocate of the High Court of Kenya;
- Member of the Law Society of Kenya;
- Commissioner for Oaths and Notaries Public;
- Member of the International Commission of Jurists;
- Member of the International Police Association;



Name: Dr. Catherine M. Kamindo

Ag. Director Research Boundaries & Development

Profession/Qualifications:

- PhD Education Policy and Management- University of Durham (UK);
- Master of Education Educational Administration- Kenyatta University;
- Bachelor of Education - Kenyatta University;
- Certificate in Strategic Communication- The World Bank;
- Certificate in Management of Democratic Elections in Africa- University of South Africa;
- Professional Certificate in Electoral Processes-International Centre for Parliamentary Studies (UK);
- Full Member (FKIM) Kenya Institute of Management;
- African Union Certified Long and Short-Term Elections Observer;
- Kenya Association of Educational Administration (KAEM);
- American Political Science Association (APSA).

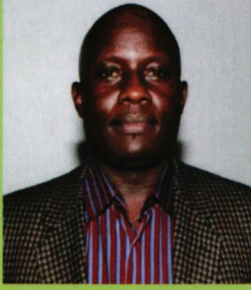

Name: Moses Sunkuli

Ag. Director Voter Registration and Electoral Operations

Profession/Qualifications Profession/Qualifications:

- MBA, Strategic Management-Kenyatta University;
- Bachelor of education, Arts –Moi University;
- Diploma in Business Management- Kenya Institute of Management;
- Certificate, Management of Democratic Elections in Africa - UNISA;
- Strategic Leadership Management Course - Kenya School of Government;
- Member (KIM) Kenya Institute of Management.



Name: Rasi Masudi

Director Voter Education, Partnerships & Communication

Profession/Qualifications:

- Executive MBA;
- Bachelor of Science in Agricultural Economics;
- Diploma in Farm Management.



Name: Harley Kisyula Mutisya

Director Supply Chain Management

Profession/Qualifications:

- PHD in Business Administration (UoN);
- MBA in Procurement & Supply Chain Management (UoN);
- BCOM in Supply Chain Management (UoN);
- Diploma in Logistical Management from Cerford Institute;
- Certified Procurement and Supply Professional (CPSP-K);
- Chartered Associate (ACI Arb);
- Member Kenya Institute of Supplies Management (KISM);
- Certified Practitioner-(KISM);
- Fellow Logistics Society of Kenya;
- Member Chartered Institute of Procurement and Supply (UK);



Name: Michael Ouma

Director ICT

Profession/Qualifications:

- MBA, Strategic Management - UoN
- B. Tech. in Electrical & Communications Engineering – Moi University.



Name: CPA Reuben Chirchir

Ag. Director Audit & Compliance

Profession/Qualifications:

- Master's in Business Administration in Finance (MBA)- USIU;
- Bachelor of Arts, BA(Hons), Economics - University of Nairobi;
- Certified Public Accountant (CPA-K);
- Member of ICPAK in good standing;
- Member of IIA –Kenya in good standing;



Name: Lorna A. Onyango

Director Human Resource & Administration

Profession/Qualifications:

- Master of Business Administration (HRM);
- Post Graduate Diploma;
- Bachelor of Arts (Sociology) (UoN);
- Certificate, Human Resource Audit;
- Certificate, Payroll Management;
- Licensed Human Resource Professional;
- Member, Institute of Human Resource Management (IHRM), Kenya.

CORPORATE GOVERNANCE STATEMENT

The Commission is accountable to the public and stakeholders through Parliament for ensuring that it complies with the highest standards of corporate governance and operational ethics. The Commission has embraced corporate governance by promoting the right corporate culture and values.

The Commission exercises reasonable care to ensure that the management of the Commission is carried out in the best interest of the citizens of Kenya. The overall management of the Commission is the responsibility of the Commissioners.

The Commission recognizes the need to conduct its affairs with integrity and in accordance with generally accepted corporate practices and internationally developed principles of corporate governance.

The Commission

The size, composition and appointment of the Commission is prescribed by Article 250 of the Constitution and by the IEBC Act 2011. There were seven Commissioners who worked on a full-time basis during the year under review. Each member was appointed to serve for a single term of six years.

The Commission is well composed in terms of range and diversity of skills, knowledge, age and experience in various sectors which makes it effective and provides an appropriate skills balance for the oversight of the Commission's mandate.

The Commission Committees and their Responsibilities

The Commission delegates certain functions to committees without abdicating its own responsibilities. The Commission has developed a committee structure that assists in the execution of its duties, powers and authorities. The Committees are appropriately constituted drawing membership from amongst the Commissioners with the appropriate set of skills and experience and directors co-opted from various directorates.

The Commission has in place an independent Audit Committee that is chaired by a non-executive member. It also has two independent audit committee members, from the National Treasury and Ministry of ICT and one Commissioner.

The Audit, Risk and Compliance Committee oversees the internal audit activity charged with the responsibility of continuous review and providing assurance on effectiveness of the Commission's Governance, Risk and Control.

Mortgage and Car Loan Committee

During the 2021/2022 financial year, the IEBC Mortgage and Car Loan scheme was managed by the following members:

Members	Responsibility
Obadiah Keitany	Chairperson
Lorna Onyango	Vice Chairperson
Dr. Eroo Mele	Member
Sahara Ibrahim	Member
Salome Oyugi	Member
Arnold Wekesa	Member

Impartiality and Independence of Members

Every member of the Commission and employee shall perform their functions impartially and independently without influence from any person, authority or organization.

Disclosure of Conflict of Interests

If a member of the Commission or an employee is directly or indirectly interested in any matter before the Commission and is present at any meeting of the Commission at which the matter is the subject of consideration, he/she shall as soon as practicable disclose the fact and shall not take part in the consideration or discussion of, or vote on, any questions with respect to the matter or be counted in the quorum of the meeting during consideration of the matter.

A member or employee whose personal interest conflicts with their official duties shall in writing, declare as soon as practicable the personal interests to their supervisor or other appropriate person or body and comply with any directives given to avoid the conflict and refrain from participating in any deliberations with respect to the matter.

MANAGEMENT DISCUSSION AND ANALYSIS

Operational and Financial Performance

The Commission's Mortgage and Car Loan revolving scheme is managed by Housing Finance Corporation of Kenya and was set up in March 2017.

Since its inception, one hundred and seven (107) members of staff have benefited from the scheme. Seventy four (74) have been issued with mortgages valued at Kshs. 566.823 million whereas thirty-three (33) members of staff have been issued with car loans valued at Kshs. 49.330 million.

	No. of applications made	Successful applications
Mortgage Loan Scheme applications	97	74
Car Loan Scheme applications	37	33
Total	134	107

As the end of 30th June 2022, the scheme had earned Kshs. 16.053 million from high interest earning bank balances as compared with Kshs 19.573 million earned in the similar period the previous year. Further, the Scheme earned interest on loans amounting Kshs.11.887 million as compared with Kshs.11.925 million earned for the similar period ended 30th June, 2022.

Compliance with Statutory Requirements

The Scheme complied with its tax obligations and all its statutory obligations in the implementation of its mandate.

Key Projects and Investment

The Commission has continued to invest in the mortgage and car loan schemes for the staff. This is intended to provide affordable housing for the staff while at the same time facilitating the staff to conveniently commute to and from work.

Risk Management Activities

The Commission has put in place a risk management framework for risk identification and mitigation. Further, it has embedded risk management in all its planning, execution, evaluation and business continuity arrangements.

Some of the key risks facing the Scheme include:

- **Strategic Risks:** These are risks that affect the ability to carry out the long-term goals and objectives as articulated in the Scheme Policy.
- **Compliance Risks:** These are risks associated with non-compliance with applicable laws and regulations which could result in litigation and conflicts of interest.
- **Financial Risks:** The risk of financial loss that may include ineffectiveness of internal controls, inadequate funding, inability to service the loans and delay in financial reporting due reliance on third party financial information. The delayed funding may also result in the commission's inability to fund all the applications hence the delay in issuing of loans and acquisition of the properties.

- **Operational Risks:** The risk of direct or indirect loss or inability to provide core services, especially to stakeholders, resulting from inadequate or failed internal processes, resources and systems.

Statutory and Financial Obligations

In the period under review, the scheme was able to satisfy all the applications, except where the necessary information to support compliance and due diligence was not available. Further, the Commission complied with all the necessary laws and regulations applicable in the management of the funds.

Financial Probity and Governance

To obtain assurance on compliance and prudence in the management scheme finances, the Commission prepares the financial statements for the Mortgage and Car Loan Scheme which are be subjected to both internal and external audit. The audit findings and recommendations enable the Commission to strengthen the Scheme operational and financial systems.

To obtain assurance on compliance and prudence in the management of the Scheme finances, the Commission has collaborated with the relevant statutory oversight bodies and continues to undertake internal financial reviews whose outcome enables the Commission to strengthen its operational and financial systems.

STATEMENT OF THE ACCOUNTING OFFICER RESPONSIBILITIES

Section 81 of the Public Finance Management Act, 2012, requires the Accounting Officer to prepare financial statements for each financial year that give a true and fair view of the state of affairs of the Commission as at the end of period and of its operating results. It also requires the Accounting Officer to ensure that the Commission maintains proper accounting records that disclose, with reasonable accuracy at any time, the financial position of the Commission. The Accounting Officer is also responsible for safeguarding the Commission's assets.

The Accounting Officer is responsible for the preparation and fair presentation of these financial statements in accordance with International Public Sector Accounting Standards (IPSAS) and in a form that complies with the standards prescribed by the Public Sector Accounting Standards Board (PSASB). This responsibility includes: designing, implementing and maintaining internal controls relevant to the preparation and fair presentation of financial statements that are free from material misstatement, whether due to fraud or error, safeguarding the assets, selecting and applying appropriate accounting policies, and making accounting estimates that are reasonable in the circumstances.

The Accounting Officer accepts responsibility for financial statements, which have been prepared using appropriate accounting policies supported by reasonable and prudent judgments and estimates, in conformity with International Public Sector Accounting Standards (IPSAS), and in the manner required by the PFM Act, 2012. The Accounting Officer is of the opinion that the financial statements give a true and fair view of the state of financial affairs of the Commission and of its financial position. The Accounting Officer further accept responsibility for the maintenance of accounting records that may be relied upon in the preparation of financial statements, as well as adequate systems of internal financial control.

Nothing has come to the attention of the Accounting Officer to indicate that the Commission will not remain a going concern for at least the next twelve months from the date of this statement.



Marjan Hussein Marjan
Commission Secretary/CEO

REPORT OF THE CHAIRPERSON

It gives me great pleasure to present the Commission's Staff Mortgage and Car Loan Scheme annual financial statements.

Staff welfare is a major concern for robust Commission culture. In this respect, the Commission has continued to implement the Staff Mortgage and Car Loan schemes in line with Government regulations.

In the 2021/2022 financial year, the Commission was allocated Kshs.58.362 million to finance the staff mortgage scheme. No provision was made for the Car Loan Scheme due to the budget constraints. Since inception, a total of hundred and seven (107) members of staff have benefited from the mortgage and car loan schemes.

The Commission ensured prudent financial management and reporting in line with Public Finance Management Act (PFMA) 2012, Government Financial Regulations, 2015 and International Public Sector Accounting Standards (IPSAS) resulting in efficient and effective administration of the Scheme.

I encourage all staff members to optimally utilize the facility for improvement of their welfare and to remain resilient and focused in the performance of the Commission mandate.

My gratitude goes out to the National Government, the National Treasury, Parliament, the Judiciary, other Commissions and Independent Offices, fellow Commissioners and the staff of the Commission for their support towards fulfilling our mandate.

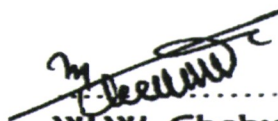
.....
W.W. Chebukati

Chairperson

REPORT OF THE INDEPENDENT AUDITOR

STATEMENT OF FINANCIAL PERFORMANCE

FOR THE YEAR ENDED 30TH JUNE, 2022

	Note	2021/2022 Unaudited Kshs 000	2020/2021 Audited Kshs 000
<u>Revenue</u>			
Interest on Free Funds	1	16,053	19,573
Interest on Loans	2	11,887	11,925
Total Revenue		27,941	31,497
<u>Expenses</u>			
Taxes on Interest Earned	3	(2,408)	(2,936)
Fund Administrative costs	4	(11,887)	(11,925)
Total Expenses		(14,295)	(14,860)
Surplus for the Year		13,645	16,637

The significant accounting policies and notes to the financial statements on page 25 to 30 form an integral part of these annual financial statements.

STATEMENT OF FINANCIAL POSITION

AS AT 30TH JUNE, 2022			
	Note	2021/2022 Unaudited Kshs 000	2020/2021 Audited Kshs 000
Assets			
Current Assets			
Cash and Cash Equivalents	5	353,465	377,201
Short Term Receivables	6	24,324	11,988
		377,789	389,189
Non-Current assets			
Long Term Receivables	7	473,397	448,352
Total Assets		851,186	837,540
Current Liabilities			
Taxes Payable	8	-	-
Total Liabilities		-	-
Net Scheme Assets		851,186	837,540
Financed by:			
Mortgage Revolving Fund		656,596	656,596
Car Loan Revolving Fund		114,194	114,194
Mortgage Reserves		48,219	38,829
Car Loan Reserves		32,177	27,922
Net Scheme Assets		851,186	837,540

The significant accounting policies and notes to the financial statements on page 25 to 30 form an integral part of these annual financial statements.

The financial statements from page 20 to 31 were approved and authorized by the Commission and signed on its behalf by:

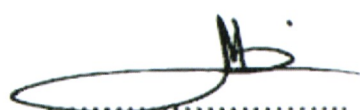

CPA Marjan H. Marjan
ICPAK M/No. 2786
Commission Secretary



CPA Osman H. Ibrahim
ICPAK M/ No. 2544
Director Finance



W.W. Chebukati
Chairperson

STATEMENT OF CASH FLOWS

AS AT 30TH JUNE 2022

	Note	2021/2022 Unaudited Kshs 000	2020/2021 Audited Kshs 000
Cash flows from Operating Activities:			
Operating Surplus		13,645	16,637
Adjustments for Non-Cash Items:			
Changes in Working Capital:			
(Increase)/Decrease in Short Term Receivables	6	(12,336)	(6,165)
Increase/(Decrease) in Tax Payables	8	-	-
Net Cash Flow from Operating Activities		1,309	10,472
Cash flows from Investing Activities:			
Long Term Receivables	7	(25,045)	(56,692)
Net Cash Flow from Investing Activities		(25,045)	(56,692)
Cash flows from Financing Activities:			
Increase in Staff Mortgage Fund	10	-	9,584
Increase in Staff Car Loan Fund	10	-	1,800
Net Cash Provided by Financing Activities		-	11,384
Net Increase in Cash & Cash Equivalent		(23,736)	(34,836)
Cash & Cash Equivalent at Beginning	5	377,201	412,037
Cash & Cash Equivalents at the End		353,464	377,201

The significant accounting policies and notes to the financial statements on page 25 to 30 form an integral part of these annual financial statements.

STATEMENT OF CHANGES IN NET ASSETS

	FOR THE PERIOD ENDING 30TH JUNE, 2022				
	Mortgage Fund	Car Loan Fund	Mortgage Reserve	Car Loan Reserve	Total
	KShs. 000	KShs. 000	KShs. 000	KShs. 000	KShs. 000
Balance as at 30th June 2016	-	26,094	-	-	26,094
Surplus for the Year	-	-	2,492	1,775	4,267
National Treasury Funding	200,000	100,000	-	-	300,000
Balance as at 30th June 2017	200,000	126,094	2,492	1,775	330,361
Surplus for the Year	-	-	8,417	7,999	16,417
National Treasury Funding	63,012	100,000	-	-	163,012
Balance as at 30th June 2018	263,012	226,094	10,909	9,774	509,789
Surplus for the Year	-	-	6,524	10,307	16,830
Inter-fund transfers	150,000	(150,000)	-	-	-
National Treasury Funding	113,000	31,100	-	-	144,100
Balance as at 30th June 2019	526,012	107,194	17,433	20,081	670,720
Surplus for the Year	-	-	9,174	3,426	12,600
National Treasury Funding	121,000	5,200	-	-	126,200
Balance as at 30th June 2020	647,012	112,394	26,607	23,507	809,520
Surplus for the Year	-	-	12,222	4,415	16,637
National Treasury Funding	9,584	1,800	-	-	11,384
Balance as at 30th June, 2021	656,596	114,194	38,829	27,922	837,540
Surplus for the Year	-	-	9,390	4,255	13,645
National Treasury Funding	-	-	-	-	-
Balance as at 30th June, 2022	656,596	114,194	48,219	32,177	851,186

The significant accounting policies and notes to the financial statements on page 25 to 30 form an integral part of these annual financial statements.

STATEMENT OF COMPARISON OF BUDGET & ACTUAL

BUDGET EXECUTION STATEMENT AS AT 30TH JUNE, 2022			
Item	Budget	Actual	Performance
Receipts	KShs '000	KShs '000	KShs '000
Housing Loans to Public Servants	58,362	58,362	100%
Car Loans to Public Servants	-	-	0%
Total Receipts	58,362	58,362	100%
Housing Loans to Public Servants	58,362	58,362	100%
Car Loans to Public Servants	-	-	0%
Total Payments	58,362	58,362	100%

SIGNIFICANT ACCOUNTING POLICIES

For the Year Ended 30th June, 2022

1. Statement of compliance and basis of preparation – IPSAS 1

The Commission's Staff Mortgage and Car Loan Scheme financial statements have been prepared in accordance with and comply with the International Public Sector Accounting Standards (IPSAS). The financial statements are presented in Kenya shillings, which is the functional and reporting currency of the Commission and all values are rounded to the nearest thousand (Kshs 000) which may in some cases make the added decimal balances to vary. The accounting policies have been consistently applied in all the years presented.

The financial statements have been prepared on the basis of historical cost, unless where stated otherwise. The cash flow statement is prepared using the indirect method. The financial statements are prepared on accrual basis.

2. Summary of Significant Accounting Policies:

s) Revenue Recognition - Revenue from Non-Exchange Transactions (Fees, Charges and Fines) – IPSAS 23

The Commission recognizes revenues from high interest bank balances earned and the asset recognition criteria are met. To the extent that there is a related condition attached that would give rise to a liability to repay the amount, deferred income is recognized instead of revenue. Other non-exchange revenues are recognized when it is probable that future economic benefits or service potential associated with the asset will flow to the Commission and the fair value of the asset can be measured reliably.

Interest Income

Interest income is accrued using the effective yield method. The effective yield discounts estimated future cash receipts through the expected life of the financial asset to that asset's net carrying amount. The method applies this yield to the principal outstanding to determine interest income each period.

t) Budget Information – IPSAS 24

The annual budget is prepared and presented in a single statement to determine the needs of the Commission. The Commission has adopted the standard which requires budget information to be presented in the financial statements.

u) Taxes – IAS 12

Income tax

Income tax assets and liabilities for the current period are measured at the amount expected to be recovered from or paid to the tax authorities. The tax rates and tax laws used to compute the amount are those that are enacted or substantively enacted, at the reporting date in the area where the Commission operates and generates taxable income.

SIGNIFICANT ACCOUNTING POLICIES

For the Year Ended 30th June, 2022

Current income tax relating to items recognized directly in net assets is recognized in net assets and not in the statement of Financial Performance. Management periodically evaluates positions taken in the tax returns with respect to situations in which applicable tax regulations are subject to interpretation and establishes provisions where appropriate.

v) Provisions – IPSAS 19

Provisions are recognized when the Commission has a present obligation (legal or constructive) as a result of a past event, it is probable that an outflow of resources embodying economic benefits or service potential will be required to settle the obligation and a reliable estimate can be made of the amount of the obligation.

Where the Commission expects some or all of a provision to be reimbursed, for example, under an insurance contract, the reimbursement is recognized as a separate asset only when the reimbursement is virtually certain.

The expense relating to any provision is presented in the statement of financial performance net of any reimbursement.

Contingent Liabilities

The Commission does not recognize a contingent liability, but discloses details of any contingencies in the notes to the financial statements, unless the possibility of an outflow of resources embodying economic benefits or service potential is remote.

Contingent Assets

The Commission does not recognize a contingent asset, but discloses details of a possible asset whose existence is contingent on the occurrence or non-occurrence of one or more uncertain future events not wholly within the control of the Commission in the notes to the financial statements. Contingent assets are assessed continually to ensure that developments are appropriately reflected in the financial statements. If it has become virtually certain that an inflow of economic benefits or service potential will arise and the asset's value can be measured reliably, the asset and the related revenue are recognized in the financial statements of the period in which the change occurs.

w) Nature and Purpose of Reserves

The Commission creates and maintains reserves in terms of specific requirements. Commission to state the reserves maintained and appropriate policies adopted.

x) Changes in Accounting Policies and Estimates – IPSAS 3

The Commission recognizes the effects of changes in accounting policy retrospectively. The effects of changes in accounting policy are applied prospectively if retrospective application is impractical.

SIGNIFICANT ACCOUNTING POLICIES

For the Year Ended 30th June, 2022

y) Cash and Cash Equivalents

Cash and cash equivalents comprise cash on hand and cash at bank, short-term deposits on call and liquid investments with an original maturity of three months or less, which are readily convertible to known amounts of cash and are subject to insignificant risk of changes in value. Bank account balances include amounts held at the Central Bank of Kenya and at various commercial banks at the end of the financial year.

z) Comparative Figures

Comparative figures for the year have been provided.

aa) Significant Judgments and Sources of Estimation Uncertainty – IPSAS 1

The preparation of the Commission's financial statements in conformity with IPSAS requires management to make judgments, estimates and assumptions that affect the reported amounts of revenues, expenses, assets and liabilities, and the disclosure of contingent liabilities, at the end of the reporting period. However, uncertainty about these assumptions and estimates could result in outcomes that require a material adjustment to the carrying amount of the asset or liability affected in future periods.

Estimates and Assumptions

The key assumptions concerning the future and other key sources of estimation uncertainty at the reporting date, that have a significant risk of causing a material adjustment to the carrying amounts of assets and liabilities within the next financial year, are described below. The Commission based its assumptions and estimates on parameters available when the financial statements were prepared. However, existing circumstances and assumptions about future developments may change due to market changes or circumstances arising beyond the control of the Commission. Such changes are reflected in the assumptions when they occur. (IPSAS 1.140)

bb) Subsequent Events – IPSAS 14

There have been no events subsequent to the financial year end with a significant impact on the financial statements.

NOTES TO THE FINANCIAL STATEMENTS

For the Year Ended 30th June, 2022

1. Interest on Free Funds

	2021/2022	2020/2021
	Unaudited	Audited
	Shs 000	Shs 000
Interest from Mortgage Free Funds Account	11,048	14,379
Interest from Car Loan Free Funds Account	5,006	5,194
Total	16,053	19,573

2. Interest on Loans

	2021/2022	2020/2021
	Unaudited	Audited
	Shs 000	Shs 000
Interest on Mortgage	11,033	11,075
Interest on Car Loans	854	849
Total	11,887	11,925

3. Tax Costs on Interest Earned

	2021/2022	2020/2021
	Unaudited	Audited
	Shs 000	Shs 000
Tax Costs on Mortgage Interest	1,657	2,157
Taxes on Car Scheme Interest	751	779
Total	2,408	2,936

4. Scheme Administrative Costs

	2021/2022	2020/2021
	Unaudited	Audited
	Shs 000	Shs 000
Mortgage Administration Costs	11,033	11,075
Car Loan Administration Costs	854	849
Total	11,887	11,925

NOTES TO THE FINANCIAL STATEMENTS

For the Year Ended 30th June, 2022

5. Cash and Bank

	2021/2022	2020/2021
	Unaudited	Audited
Bank Details	Shs 000	Shs 000
HFCK IEBC Mortgage A/c -2172923102	237,461	266,716
HFCK IEBC Car Loan A/c -2172923103	116,003	110,484
Total	353,465	377,201

6. Short Term Receivables

	2021/2022	2020/2021
	Unaudited	Audited
	Shs 000	Shs 000
Opening Balance	11,988	5,823
Repaid Mortgage Capital	(8,557)	(4,934)
Repaid Car Loan Capital	(3,431)	(889)
Accrued Mortgage Capital	19,647	8,557
Accrued Car Loan Capital	4,677	3,431
Total	24,324	11,988

7. Long Term Receivables

	2021/2022	2020/2021
	Unaudited	Audited
	Shs 000	Shs 000
Staff Mortgage Receivables	447,707	420,151
Staff Car Loan Receivables	25,690	28,201
Total	473,397	448,352

8. Tax Payable

	2021/2022	2020/2021
	Unaudited	Audited
	Shs 000	Shs 000
Opening Balance	-	-
Tax Payable on Mortgage Interest accrued	-	-
Taxes Payable on Car Loan Interest accrued	-	-
Total	-	-

NOTES TO THE FINANCIAL STATEMENTS

For the Year Ended 30th June, 2022

9. Number of Beneficiaries

The following table provides the number of beneficiaries from the Schemes creation date:

	2021/2022	2020/2021
	Unaudited	Audited
Staff who have benefited from Mortgage Fund	74	65
Staff who have benefited from Car Loan Fund	33	28
Total	107	93

10. Transfers from IEBC Vote 2031 to KCB Account

As at the end of the year under review, the Commission had set aside 2021/2022 Financial Year funds amounting Kshs.58.362 Million at KCB Bank Account. These funds have been earmarked for use as seed capital for the KCB Mortgage and Car Loan scheme in 2022/2023 financial year.

11. Mortgage and Car Loans Issued

As at the end of period under review, the value of mortgages and car loans issued to staff since inception were as disclosed below:

	2021/2022	2020/2021
	Unaudited	Audited
Mortgage Loan	566,823	506,167
Car Loans	49,330	51,990
Total	616,153	558,157

12. Entity Tax Status

The Commission is a government agency, fully funded by the government and is therefore tax exempt. The Commission pays taxes as per the regulations.

13. Subsequent Events

The Commission is not aware of any matter or circumstances arising after the end of the financial year, not otherwise dealt with in the financial statements, which would significantly affect the financial position and the results of its operations as laid out in these financial statements.

PROGRESS ON FOLLOW UP OF AUDIT RECOMMENDATIONS

The IEBC Staff Mortgage and Car Loan Scheme did not have any audit follow up issues for the previous financial years.



.....
Marjan H. Marjan
ICPAK M/No. 2786
Commission Secretary



Chairperson

ANNEXES

Annex 1: Constitutional Petitions 2021/2022 Financial Year

S/NO	REFERENCE NUMBER	COURT CASE NUMBER	PARTIES INVOLVED
1	IEBC/CP/25/2021	NAIROBI PETITION NO.345 OF 2021	Nornael Okello Oganyo Vs IEBC, National Assembly And Hon.AG
2	IEBC/CP/26/2021	NAIROBI PETITION NO.335 OF 2021	Samwel Clinton Elijah Vs Wafula Chebukati, IEBC
3	IEBC/CP/27/2021	NAIROBI PETITION NO.348 OF 2021	Senator Paul Njoroge Ben Vs IEBC, Hon. Uhuru Kenyatta, National Assembly, Senate And 4 Others
4	IEBC/CP/28/2021	NAROK PETITION NO.7 OF 2019	Luke Obare Owino Vs IEBC, Hon.AG
5	IEBC/CP/29/2021	NAIROBI PETITION NO.E435 OF 2021	Charles Makhoha Sumba & Others Vs IEBC, Hon. AG
6	IEBC/CP/30/2021	NAIROBI PETITION NO.E458 OF 2021	Ahmed Rasid Koriyow Abdi Vs EBC, Hon. Haji Abdul Korir Mohamed
7	IEBC/CP/31/2021	ELDORET PETITION NO.E025 OF 2021	Patrick Toroitich Cherono Vs IEBC, The National Assembly
8	IEBC/CP/32/2021	NAIROBI PETITION NO. E465 OF 2021	Boaz Atanga Waruku Vs IEBC (KIEMS Kit)
9	IEBC/CP/33/2021	NAKURU PETITION NO. E028 OF 2021	Boniface Mwai Gachunga Vs IEBC
10	IEBC/CP/34/2021	NAIROBI PETITION NO. E488 OF 2021	Stephen Moseti Mirambo Vs IEBC, Smartmatics International Holding Ltd (KIEMS Kit)
11	IEBC/CP/35/2021	NAIROBI PETITION NO.E503 OF 2021	Okiya Omtatah Okoiti Vs IEBC And Others (Governor and Deputy Governors)
12	IEBC/CP/36/2021	NAIROBI PETITION NO.E014 OF 2021	Paul Macharia, Joseph Karanja Muchai & Another Vs IEBC, Hon. AG
13	IEBC/CP/37/2021	NAIROBI PETITION NO. E536 OF 2021	Eric Omari Wanyama Vs IEBC (Public Officers)
14	IEBC/CP/38/2021	NAIROBI PETITION NO.E546 OF 2021	Transparency International Kenya As Consolidated With Petition No.E540 of 2021)Campaign Finance Vs Speaker National Assembly, IEBC
15	IEBC/CP/39/2021	NAIROBI PETITION NO.E549 OF 2021	Donald Makana Vs IEBC, Hon. AG, Speaker National Assembly (Degrees For Mps)
16	IEBC/CP/40/2021	NAIROBI PETITION NO.E540 OF 2021(AS CONSOLIDATED WITH E546 OF 2021)	Katiba Institute, AFRICOG, Transparency International Kenya Vs IEBC, Hon. AG
17	IEBC/CP/41/2021	NAIROBI PETITION NO.E 504 OF 2021-	Peter Odhiambo Agoro & Others Vs Hon. Paul Mutunga, IEBC
18	IEBC/CP/42/2021	MOMBASA PETITION NO. 100 OF 2021	Douglas Owiye Onyango & 3 Others Vs IEBC, Hon. AG

S/NO	REFERENCE NUMBER	COURT CASE NUMBER	PARTIES INVOLVED
19	IEBC/CP/1/2022	NAIROBI PETITION NO. E004 OF 2022	Okiya Omtatah Okoiti Vs IEBC Hon. AG (Diaspora Polling Stations)
20	IEBC/CP/2/2022	NAIROBI PETITION NO.E004 OF 2022	George Bush & Seleb John Kengah Vs IEBC, DPP, ODM, Raila Odinga (Crime Case)
21	IEBC/CP/3/2022	NAIROBI PETITION NO. E043 OF 2022	Salesio Mutuma Thurania Vs IEBC, ORPP, Hon. AG. Speaker of The Senate, National Assembly
22	IEBC/CP/4/2022	KISUMU PETITION NO. 060 OF 2022	Caleb Gichana Vs CEO Chemil Sugar Lts, PSC, Hon. AG
23	IEBC/CP/5/2022	NAIROBI PETITION NO.E057 OF 2022	Katiba Institute, ICJ, KHRC Vs Speaker National Assemblies, Hon. AG, IEBC
24	IEBC/CP/6/2022	ELDORET PETITION NO. E004 OF 2022	Samuel Kiprono Chepkonga Vs IEBC, Hon. AG
25	IEBC/CP/7/2022	KISUMU PETITION NO. E002 OF 2022	Cornel Otiendo Onyango & 2 Others Vs IEBC, Hon. AG
26	IEBC/CP/8/2022	MOMBASA PETITION NO.E005 OF 2022	Caroline Andazi Chilango & Another Vs IEBC
27	IEBC/CP/9/2022	NAIROBI PETITION NO.E065 OF 2022	Adrain Kamotho Njenga Vs IEBC, Hon. AG, The Senate
28	IEBC/CP/10/2022	NAIROBI PETITION NO.E073 OF 2022	Hon. Sabina Chege Vs IEBC
29	IEBC/CP/11/2022	MACHAKOS PETITION NO.2 OF 2022	Centre For Minority Right Development & Cemirade & 3 Others Vs Hon. AG, The Speaker of the National Assembly, The Senate
30	IEBC/CP/12/2022	NAIROBI PETITION NO. E77 OF 2022	Hon. Kipas Lungues Noonyuat & 2 Others Vs Hon. AG, Speaker of The National Assembly to the Senate (Degree Issues)
31	IEBC/CP/13/2022	NAIROBI PETITION NO. E085 OF 2022	Joe Kamau Vs Hon. AG, RPP, IEBC
32	IEBC/CP/14/2022	NAIROBI PETITION NO.E089 OF 2022	Eliud Karanja Matindi, Kenya Diaspora Alliance Usa Vs IEBC Commissioners, CAJ
33	IEBC/CP/15/2022	NAIROBI PETITION NO.E090 OF 2022	Okiya Omtatah Okoiti Vs IEBC Hon.AG
34	IEBC/CP/16/2022	MOMBASA PETITION NO.E007 OF 2022	George Mututu Vs IEBC, Taita Taveta Constituency
35	IEBC/CP/17/2022	NAIROBI PETITION NO.E109 OF 2022	Usawa Kwa Wote Party Vs Hon. AG, ORPP
36	IEBC/CP/18/2022	MOMBASA PETITION NO.E009 OF 2022	Yusuf Gitau Abdallah Vs IEBC
37	IEBC/CP/19/2022	NAKURU PETITION NO. E004 OF 2022	Peter Kibe Mbae Vs IEBC
38	IEBC/CP/20/2022	NAIROBI PETITION NO. E122 OF 2022	Michael Makarena Vs KRA, EACC, Mithika Linturi, IEBC
39	IEBC/CP/21/2022	VIHIGA PETITION NO.E004 OF 2022	Noah Asanga Okaya Vs Vihiga County Assembly, IEBC, ODM & Another
40	IEBC/CP/22/2022	NAIROBI PETITION NO.	Hon. Moses Kuria Vs IEBC

S/NO	REFERENCE NUMBER	COURT CASE NUMBER	PARTIES INVOLVED
		E136 OF 2022	
41	IEBC/CP/23/2022	NAIROBI PETITION NO.E147 OF 2022	Ekuru Aukot & Miruru Waweru Vs Hon. AG, Raila Odinga,Kalonzo Musyoka, Musalia Mudavadi And IEBC
42	IEBC/CP/24/2022	NAIROBI PETITION NO.E149 OF 2022	International Policy Group Vs Jubilee Party, RPP, Kembi Gitura And IEBC
43	IEBC/CP/25/2022	NAIROBI PETITION NO. E160 OF 2022	Free Kenya Initiative, Bob Ngagi Vs IEBC
44	IEBC/CP/26/2022	NAIROBI PETITION NO. E152 OF 2022	Robert Ndana Mutie Vs Hon. AG, IEBC
45	IEBC/CP/27/2022	NAKURU PETITION NO. 9 OF 2022	Legal Advice Centre Vs IEBC,Dpp,Rpp
46	IEBC/CP/28/2022	NAIROBI PETITION NO. E163 OF 2022	Kennedy Kariithi Gachenge Vs UDA, ORPP, IEBC
47	IEBC/CP/29/2022	NAIROBI PETITION NO. E155 OF 2022	Charles Rubia Vs Noordian Haji, DPP, EACC, DCI, National Police Service, IEBC
48	IEBC/CP/30/2022	NAIROBI PETITION NO. E174 OF 2022	The Equitable Party, Dr. Patrick Salsi Vs IEBC
49	IEBC/CP/31/2022	MOMBASA PETITION NO.E017 OF 2022	Nooro Kayuga (Sonko Nomiation To Msa Governor) Vs IEBC
50	IEBC/CP/32/2022	NAIROBI PETITION NO.E168 OF 2022	Inuka Kenya Ni Sisi,Wanjiru Gikonyo & Another Vs EACC, Hon. AG, IEBC & DPP
51	IEBC/CP/33/2022	NAIROBI PETITION NO. E183 OF 2022	Eliud Matindi (Audit Of Voter Register 2022) Vs IEBC, KPMG, The Senate
52	IEBC/CP/34/2022	BOMET PETITION NO. 2 OF 2022	Ogiek Independent Council Of South West, Mau Forest, Charles Kibet Ngetich & Another Vs IEBC, Hon. AG, County Government of Bomet, Centre For Minority Developments Right
53	IEBC/CP/35/2022	NAIROBI PETITION NO. E200 OF 2022	Moses Kuria Vs IEBC,Hon.AG
54	IEBC/CP/36/2022	NAIROBI PETITION NO.E199 OF 2022	Francis Githinji Vs IEBC,Hon.AG
55	IEBC/CP/37/2022	ELDORET PETITION NO. E199 OF 2022	Silvester Kipkeoi Arap Vs Mike Sonko, Ferdianrd Ndungu Waititu,IEBC
57	IEBC/CP/39/2022	KISUMU PETITION NO. 2 OF 2022	Umullo Okowa Vs ORPP, IEBC
58	IEBC/CP/40/2022	KAKAMEGA PETITION NO. E008 OF 2022	Moses Mirikau Ombayo Vs Habil Nanjenga Bushuru, ORPP, Amani National Congress
59	IEBC/CP/41/2022	NAIROBI PETITION E219 OF 2022	Benard Neto Obunga, Joseph Siambai Yamo Hanga & Others Vs IEBC, Hon. AG & 2 Others
60	IEBC/CP/42/2022	NAIROBI PETITION NO. E211 OF 2022	Cliff Marube Ombeta Vs UDA, IEBC & Another
61	IEBC/CP/43/2022	NAIROBI PETITION NO. 221 OF 2022	Edward Asitiba Trading As Edward C. Astiba Associates Advocates Vs IEBC, EACC, Commission on Administrative Justice

S/NO	REFERENCE NUMBER	COURT CASE NUMBER	PARTIES INVOLVED
62	IEBC/CP/44/2022	MOMBASA PETITION NO. E021 OF 2022	Kelvin Roy Omondi, Fatuma Saidi Sauti Vs RPP, IEBC, Azimio La Umoja One Kenya Alliance
63	IEBC/CP/45/2022	BUSIA PETITION NO. 2A OF 2022(FORMERLY NAIROBI PETITION NO, E208 OF 2002)	Fredrick Warua Juma Vs Jubilee Party Of Kenya, Nibert Omanyoo Wabwire, IEBC
64	IEBC/CP/46/2022	NAIROBI PETITION NO. E230 OF 2022	Mukidi D. Jwenge & Anderson Warui Vs Mike Mbuvi Sonko, IEBC, EACC & Another (Sonko Issues)
65	IEBC/CP/47/2022	KISII PETITION NO. E007 OF 2022	Thomas Obare Nyabaro Vs ODM Election Board, Bilango Muturwe, ODM And IEBC
66	IEBC/CP/48/2022	KAKAMEGA PETITION NO. E010 OF 2022	Kaira Nabasenge Vs IEBC, Hon. AG
67	IEBC/CP/49/2022	NAIROBI PETITION NO. E234 OF 2022	Kelvin Njui Wangari Vs Paul Karungo Thangwa, IEBC, Hon. AG, EACC & Another
68	IEBC/CP/50/2022	NAIROBI PETITION NO.E258 OF 2022	Simon Nyakoe Obuba & 31 Others Vs IEBC 7 Hon. AG
69	IEBC/CP/51/2022	NAIROBI PETITION NO. E264 OF 2022	Fred Muka Vs Hon. Cleophas W. Malala, CRO Kakamega County, IEBC
70	IEBC/CP/52/2022	NAIROBI PETITION NO. E 263 OF 2022	Frankline Shiling Anguche Vs CRO Kakamega County, IEBC
71	IEBC/CP/53/2022	NAIROBI PETITION NO.260 OF 2022	Nazlin Omar Fazaldin Rajput Vs IEBC, Hon. AG & Another
72	IEBC/CP/54/2022	VIHIGA PETITION NO.E004 OF 2022	Evans Ladtema Muswahili Vs IEBC
73	IEBC/CP/55/2022	NAIROBI PETITION NO. E275 OF 2022	Reuben Kigame Lichete Vs IEBC Wafula Chebukati
74	IEBC/CP/56/2022	NAIROBI PETITION NO. E276 OF 2022	Leonard Nyendwe Vs IEBC, EACC, Hon. Dismus Ballotpare
77	IEBC/CP/57/2022	NAIROBI PETITION NO. E279 OF 2022	Steve Biko Vs IEBC, ORPP, DCI, Hon. AG, ICT Authority, Data Protection Commission Kenya
78	IEBC/CP/58/2022	NAIROBI PETITION NO.17 OF 2022	Jacob Oanda Nyagoko Vs IEBC Chairman
77	IEBC/CP/59/2022	NAIROBI PETITION NO. 290 OF 2022	Victor Buoga Vs Hon.AG,IEBC
78	IEBC/CP/60/2022	NAIROBI PETITION NO.E291 OF 2022	Agnes Nailantei Shonko Wachira Vs Ro Kasarani Constituency, IEBC
79	IEBC/CP/61/2022	MIGORI PETITION NO.E002 OF 2022	Calvince Otieno & Another Vs Returning Officer Rongo Constituency & Another
80	IEBC/CP/62/2022	NAIROBI PETITION NO.E297 OF 2022	Mugambi Imanyara Vs IEBC
81	IEBC/CP/63/2022	NAIROBI PETITION NO.E306 OF 2022	Kenya Human Rights, Haki Yetu, ICJ, Katiba Institute (Manual Voter Register Issues) Vs IEBC, National Returning Officer-Wafula Chebukati

S/NO	REFERENCE NUMBER	COURT CASE NUMBER	PARTIES INVOLVED
82	IEBC/CP/64/2022	NAIROBI PETITION NO. E315 OF 2022	Issa Kumo Vs Ali Bunow Karane, IEBC, CRO Garissa County & CUE
83	IEBC/CP/65/2022	NAIROBI PETITION NO. 316 OF 2022	Abdinoor Bashir Takal Vs Nathif Jama Adam, IEBC And CRO Garissa County
84	IEBC/CP/66/2022	NAIROBI PETITION NO. 313 OF 2022	Losikany James Vs IEBC
85	IEBC/CP/67/2022	KITUI PETITION NO. E304 OF 2022	Amb.Julius Kiema Kilonzo Vs IEBC
86	IEBC/CP/68/2022	NAIROBI PETITION NO. E321 OF 2022	Dennis Gakuu Wahome Vs IEBC
87	IEBC/CP/69/2022	NAIROBI PETITION NO.E117 OF 2022	James Kariuki Karanja Vs IEBC
88	IEBC/CP/70/2022	NAIROBI PETITION NO. E320 OF 2022	Hon. Ahmed Boray Arale Vs IEBC, Abdibashir Alinoor Ibrahim
89	IEBC/CP/71/2022	NAIROBI PETITION NO.E286 OF 2022	Hon. Mwangi Wa Iria Vs IEBC, Hon. Ag
90	IEBC/CP/72/2022	KISII PETITION NO. E286 OF 2022	Herbert Nyaruri Moranga Vs Hilda Imbo & IEBC
91	IEBC/CP/73/2022	GARISSA PETITION NO. 10B OF 2022	Nicholas Waitito Njau Vs Mohamed Subey Gedi, IEBC, Hon. Ag & Another
92	IEBC/CP/74/2022	MOMBASA PETITION NO.E029 OF 2022	Maur Abdalla Bwanamaka & 3 Others Vs IEBC,Chama Cha Uzalendo
93	IEBC/CP/75/2022	NAIROBI PETITION NO. E326 OF 2022	Richard K. Sibilibili Vs The President Of The Republic of Kenya, CS Interior, Hon. William Ruto, IEBC & Another
94	IEBC/CP/76/2022	MIGORI PETITION NO. 1 OF 2022	Fredrick Omondi Otieno Vs Oluoch Onyango Nelson, Returing Officer Rongo Constituency
95	IEBC/CP/77/2022	NAIROBI PETITION NO. E323 OF 2022	Jeremiah Kiwoi Vs Granton Samboja, KNEC, IEBC & Another
96	IEBC/CP/78/2022	NAIROBI PETITION NO. E396 OF 2022	Kenya Himan Right, Katiba Institute Vs IEBC
97	IEBC/CP/79/2022	NAIROBI PETITION NO.E336 OF 2022	Timothy Charo Odhiambo Vs IEBC, CRO Nairobi County,Sakaja Johnson Arthur
98	IEBC/CP/80/2022	NAIROBI PETITION NO.E335 OF 2022	Anthony Macharia Muthee Vs IEBC, Hon. Ag, Johnson Sakaja Arthur & 2 Others
99	IEBC/CP/81/2022	NAIROBI PETITION NO.332 OF 2022	David Gitau Vs IEBC,CRO Nairobi County, Sakaja Johnson Arthur
100	IEBC/CP/82/2022	NAIROBI PETITION NO.322 OF 2022	Asha Abdullahi Jubasse Vs IEBC-Wafula Chebukati
101	IEBC/CP/83/2022	NAIROBI PETITION NO.E317 OF 2022	Philip K.Langat Vs IEBC
102	IEBC/CP/84/2022	MALINDI PETITION NO. 4B OF 2022	Kabibi Bakali Ali Vs Hon.Maitha Gideon Mungaro, KNEC, DPP
103	IEBC/CP/85/2022	NAIROBI PETITION NO.E344 OF 2022	Bernard Odero Okello Vs George Luchiri Wanjakoya, KNHC British High Commission And IEBC

S/NO	REFERENCE NUMBER	COURT CASE NUMBER	PARTIES INVOLVED
104	IEBC/CP/86/2022	CHUKA PETITION NO.E002 OF 2022	Gitonga Chukam Saverio Vs CRO Tharaka Nithi County And IEBC
105	IEBC/CP/87/2022	MOMBASA PETITION NO.E027 OF 2022	Hon. Mike Mbuvi Sonko Gideon Kioko Vs Swaleh Ibrahim Yusuf, CRO Mombasa County, Wiper Party And IEBC
106	IEBC/CP/88/2022	NAIROBI PETITION NO. E333 OF 2022	James Kariuki Karanja Vs Patrick Thuku Karemeri, Returning Officer Kasarani Constituency, ORPP
107	IEBC/CP/89/2022	MERU PETITION NO.E006 OF 2022	Joseph Kariithi Vs IEBC, DPP, CRO Meru County, EACC & Mithika Linturi
108	IEBC/CP/90/2022	NAIROBI PETITION NO. E325 OF 2022	Ekuru Aukot & Miruru Waweru Vs IEBC Wafula Chebukati, ORPP & 19 Others
109	IEBC/CP/91/2022	MERU PETITION NO. E007 OF 2022	Isaiah Kithinji Vs Hon. Titus Ntuchiu, CRO Meru County, EACC, IEBC And IEBC
110	IEBC/CP/92/2022	MERU PETITION NO. E005 OF 2022	Dickson Mwenda Kithinji Vs IEBC,CRO Meru County, Kawira Mwangaza
111	IEBC/CP/93/2022	NAKURU PETITION NO.11 OF 2022	Daniel Mahiri Vs Tabitha Karanja Keroche, UDA,KRA EACC
112	IEBC/CP/94/2022	KISII PETITION NO. 10 OF 2022	Nashon Kembero Mogonchi
113	IEBC/CP/95/2022	NAIROBI PETITION NO. 3 OF 2022	Mauricce Otebangor Omusolo Vs IEBC,RO Teso South Constituency
Court Of Appeal Matters 2021 To 2022fy			
		COURT CASE NUMBER	Parties Involved (<i>Litigants And Respondents</i>)
S/NO.	OUR REF:		
1	IEBC/CA/15/2022	NAIROBI COURT OF APPEAL NO. E711 OF 2021	IEBC Vs Chama Cha Kazi, Milton Mwendwa And Salesio Mutuma Thurairia
2	IEBC/CA/16/2022	NAIROBI CIVIL APPEAL NO.E427 OF 2021	Risk Africa Innovatis Ltd Vs Smartmatic International, IEBC & 3 Others
3	IEBC/CA/17/2022	NAIROBI COURT OF APPEAL NO.E390 OF 2021	Hon.Anne Wanjiku Kibeh Vs Hon.Clement Kungu Waibara & IEBC
	IEBC/CA/1/2022	NAIROBI COURT OF APPEAL NO. E008 OF 2022	Risk Africa Innovatis Ltd Vs Smartmatic International Holdings B.V. IEBC
	IEBC/CA/2/2022	NAIROBI COURT OF APPEAL NO.022 OF 22	Hon.Attorney General Vs Isaac Mugo & 32 Others
5	IEBC/CA/3/2022	KISUMU COURT OF APPEAL NO. E139 OF 2022	IEBC Vs Wanyama Murabwa Jon
6	IEBC/CA/4/2022	NAIROBI COURT OF APPEAL NO.E124 OF 2022	Khelef Khalifa Vs Wafula Chebukati,Hon.Raila Odinga And Stephen Musyoka
Political Parties Disputes Complaints 2022			
1	IEBC/PPDTC/1/2022	NAIROBI PPDTC NO.E01 OF 2022	Mungai Wairuri And Joseph Kirputo Ngeno Vs RPP ,UDM & 3 Others
2	IEBC/PPDTC/2/2022	NAIROBI PPDTC NO.E01 OF 2022	Nicholas Kut Ochogo Vs ODM,Samuel Omunga Atandi & IEBC

S/NO	REFERENCE NUMBER	COURT CASE NUMBER	PARTIES INVOLVED
3	IEBC/PPDTC/3/2022	NAIROBI PPDTC NO.E016 OF 2022	Koskei Gilbert Kipsangyo Vs UDA, Nomination Dispute Committee And IEBC
4	IEBC/PPDTC/4/2022	NAIROBI PPDTC NO.E002 OF 2022	Joseph Muriithi Njoka Vs UDA Elections Board,UDA Party And IEBC
5	IEBC/PPDTC/5/2022	NAIROBI PPDTC NO.E002 OF 2022	David Kubasu Shimenge Vs Anc,Ramadhan Butichi And IEBC
6	IEBC/PPDTC/6/2022	NAIROBI PPDTC NO.E008 OF 2022	Julius S Nyabok Vs ODM And IEBC
7	IEBC/PPDTC/7/2022	NAIROBI PPDTC NO.E007 OF 2022	Peter Juma Awuor Vs Eric Omolo,ODM
8	IEBC/PPDTC/8/2022	NAIROBI PPDTC NO.E005 OF 2022	Collins Oiro Vs ODM And IEBC
9	IEBC/PPDTC/9/2022	NAIROBI PPDTC NO.E011 OF 2022	Billiah Bochaberi Maranga Vs ODM And IEBC
10	IEBC/PPDTC/10/2022	KISUMU PPDTC NO.E006 OF 2022	Loice Akoth Kawaka Vs ODM And IEBC
11	IEBC/PPDTC/11/2022	NAIROBI PPDTC NO.E012 OF 2022	Geoffrey Otieneo Opiyo Vs ODM And IEBC
12	IEBC/PPDTC/12/2022	NAIROBI PPDTC NO.E006 OF 2022	Kagiri Diana & Damaris Muthoni Vs Samson Ngigi Mukora,UDA And IEBC
13	IEBC/PPDTC/13/2022	NAIROBI PPDTC NO.E005 OF 2022	Mucacu Elias Kariuki Vs John Kamau Munyua,UDA and IEBC
14	IEBC/PPDTC/14/2022	NAIROBI PPDTC NO.E008 OF 2022	Joseph Njoroge Ngigi Vs Jubilee Party, Rpp And IEBC
15	IEBC/PPDTC/15/2022	NAIROBI PPDTC NO.E056 OF 2022	Boaz Kiprop Cheluget Vs UDA Party, George Washington Karani And IEBC
16	IEBC/PPDTC/16/2022	NAIROBI PPDTC NO.E003 OF 2022	Gasper Mafuti Vs Democratic Action Party, IEBC And Another
17	IEBC/PPDTC/17/2022	NAIROBI PPDTC NO.E003 OF 2022	Eliud Kimali Murimi Vs Fredrick Oduor,ODM And IEBC
18	IEBC/PPDTC/18/2022	NAIROBI PPDTC NO.E002 OF 2022	Abrari Mohamed Omar Vs Kelvin Odieki,ODM Party And IEBC
19	IEBC/PPDTC/19/2022	NAIROBI PPDTC NO.E006 OF 2022	Paul Bwire Ouma Vs Jubilee Party Of Kenya,Charles Nderitu Gichangi & IEBC
20	IEBC/PPDTC/20/2022	NAIROBI PPDTC MISC.E001 OF 2022	Everlyn Kemunto Ontiri Vs United Progressive Party,IEBC And Another
21	IEBC/PPDTC/21/2022	NAIROBI PPDTC E075 OF 2022	Deka Ali Khala Vs ODM Elections Board, Hussein Weyten Mohamed Abdirahaman And IEBC
22	IEBC/PPDTC/22/2022	NAIROBI PPDTC E073 OF 2022	Johnson Oginga Oduk & Others Vs ODM Elections Board, David Mberia And IEBC
23	IEBC/PPDTC/23/2022	NAIROBI PPDTC E001 OF 2022	David Ayoi Vs ODM Elections Board,Kennedy Swaka And IEBC

S/NO	REFERENCE NUMBER	COURT CASE NUMBER	PARTIES INVOLVED
24	IEBC/PPDTC/24/2022	NAIROBI PPDTC E077 OF 2022	Jemnyango Moses Kamalik Vs ODM Elections Board, Abdisalim Hasan Abdi
25	IEBC/PPDTC/25/2022	NAIROBI PPDTC E078 OF 2022	Hon.Musdaf Hussein Abdullahi Vs The National Elections Board,ODM,Hon.Hassan Noor Hassan And IEBC
26	IEBC/PPDTC/26/2022	NAIROBI PPDTC E067 OF 2022	Michael Thiongo Kinyajui Vs Jubilee Party of Kenya,John Kamau Muthiga And IEBC
27	IEBC/PPDTC/27/2022	NAIROBI PPDTC E070 OF 2022	Francis Mwega Kamau Vs Jubilee Party of Kenya,John Kamau Wanjohi And IEBC
28	IEBC/PPDTC/28/2022	NAIROBI PPDTC E081 OF 2022	Hon.Sunjeev Kaur Birdi Vs ODM National Elections Board, ODM, Hon. Wetangula Timothy Wanyonyi
29	IEBC/PPDTC/29/2022	NAIROBI PPDTC E017 OF 2022	Clement T Wasike Vs ODM Party, Catherine Mumo, Isoe Achoki and IEBC
30	IEBC/PPDTC/30/2022	NAIROBI PPDTC E080 OF 2022	Hassan Abdikadir Digale Vs United Democratic Party, Hussein Ahmed Mohamed and IEBC
31	IEBC/PPDTC/31/2022	NAIROBI PPDTC E09 OF 2022	Anastasia Muchiri Vs Democratic Action Party, Joshua Wekesa Pilasia IEBC & Another
32	IEBC/PPDTC/32/2022	NAIROBI PPDTC E001 OF 2022	Kenya Council of Employment & Migration Agencies, Evans Nyambega Akuma Vs Hon.Dhadho Godhana, ODM, National Elections Board and IEBC
33	IEBC/PPDTC/33/2022	NAIROBI PPDTC E001 OF 2022	Kenya Council Of Employment & Migration Agencies, Vs United Democratic Party Nominations Board and IEBC
34	IEBC/PPDTC/34/2022	NAIROBI PPDTC E002 OF 2022	Hon. Edwin Otieno, ODM Elections Board, ODM Party Vs Eunice Rahel Achieng and IEBC
35	IEBC/PPDTC/35/2022	NAIROBI PPDTC E003 OF 2022	Hon.John Mbewa Gare Vs ODM National Elections Board, ODM Party, Trufosa Osewe Odinga and IEBC
36	IEBC/PPDTC/36/2022	NAIROBI PPDTC E085 OF 2022	Mohamed Adan Mohamed Vs Wiper Democratic Movement, Marcos Kithuka Makau And IEBC
37	IEBC/PPDTC/37/2022	NAIROBI PPDTC E087 OF 2022	Fatima Haji Somo ODM Elections Board,Uba Abdi Gedhi and IEBC
38	IEBC/PPTDC/38/2022	KISUMU PPDTC NO.E019 OF 2022	John Adiwa Mwai Vs ODM Elections Board, ODM Party Returnig Officer Bondo and IEBC
38	IEBC/PPDTC/38/2022	NAIROBI PPDTC E030 OF 2022	Seth Baraka Ochieng Vs ODM Elections Board,ODM Party, Charles Mark Okose and IEBC

S/NO	REFERENCE NUMBER	COURT CASE NUMBER	PARTIES INVOLVED
39	IEBC/PPDTC/39/2022	NAIROBI PPDTC E029 OF 2022	Ted Marvin Odhiambo Vs ODM Elections Board,ODM Party, Nick Evance Okoth Ochola and IEBC
40	IEBC/PPDTC/40/2022	NAIROBI PPDTC E091 OF 2022	Hon. Siyad Hussein Jimale Vs UDA, Haji Salat and IEBC
41	IEBC/PPDTC/41/2022	KISUMU PPDTC E031 OF 2022	Richard Malela Odare Vs Democratic Party of Kenya, Raga Othim And IEBC
42	IEBC/PPDTC/42/2022	NAIROBI PPDTC E009 OF 2022	John Boiywo Kipchirchir Vs IEBC And Another
43	IEBC/PPDTC/43/2022	NAIROBI PPDTC E094 OF 2022	Daniel Ouma Odeny Vs Jalome Onyango Ochieng, Dmocratic Action Party And IEBC
44	IEBC/PPDTC/44/2022	NAIROBI PPDTC E003 OF 2022	John Ombewa Gare Vs ODM Party Of Kenya, Trufosa Osewa Odinga
45	IEBC/PPDTC/45/2022	NAIROBI PPDTC E017 OF 2022	John Ombewa Gare Vs ODM Party Of Kenya, Trufosa Osewa Odinga
46	IEBC/PPDTC/46/2022	NAIROBI PPDTC E012 OF 2022	Johnstone Alusiola Mukubwa Vs Democratic Action Party Of Kenya, Lidzanga Boniface And IEBC
47	IEBC/PPDTC/47/2022	NAIROBI PPDTC E098 OF 2022	David Njilithia Mberia Vs ODM Elections Board, Antony Maragu Muthoni & IEBC
48	IEBC/PPDT/48/2022	KAKAMEGA PPDTC NO.E011 OF 2022	Joab Mwamto Amukhale Va Amani National Congress Party And Another
49	IEBC/PPDTC/49/2022	NAIROBI PPDTC NO.E100 OF 2022	Hon. Mohamed Mahaud Vs Jubilee Party and IEBC
50	IEBC/PPDTC/50/2022	NAIROBI PPDTC NO.E036 OF 2022	Gladys Kemunto Auga Vs UDA, ORPP and IEBC
DISPUTE RESOLUTION PETITIONS ARISING FROM PARTY PRIMARIES 2022(DRC PETITIONS)			
1	IEBC/DR/1/2022	NAIROBI PETITION NO.E305 OF 2022	Oluoch Nelson Onyango Vs IEBC, Returning Officer Rongo Constituency, Nicholas Ouma Mbago
2	IEBC/DR/2/2022	NAIROBI JUDICIAL REVIEW NO.E303 OF 2022	Oscar Oluoch Ouma Vs Returing Officer Ndiwa Constituency,ODM Party,Loice Akoth Kanaka and Another
3	IEBC/DR/3/2022	NAIROBI JUDICIAL REVIEW NO.91 OF 2022	Abdullahi Mamo Sode Vs Returnign Officer Ruaraka, IEBC Dispute Resolution Committee
4	IEBC/DR/4/2022	NAIROBI JUDICIAL REVIEW MISC.NO.E083 OF OF 2022	Jimi Richard Wanjigi Vs Wafula Chebukati, IEBC Dispute Resolution Committee
5	IEBC/DR/5/2022	NAIROBI JUDICIAL REVIEW NO.101 OF 2022	Fredrick Owino Obenge Vs Returning Officer Kibra Constituency, Dispute Resolution Committee
6	IEBC/DR/6/2022	MOMBASA JUDICIAL REVIEW NO.018 OF 2022	Wiper Democratic Movement Party Vs CRO Mombasa County,IEBC Gideon Mbuvi Mike Sonko Eacc And Another

S/NO	REFERENCE NUMBER	COURT CASE NUMBER	PARTIES INVOLVED
7	IEBC/DR/7/2022	NAIROBI JUDICIAL REVIEW NO.E082 OF 2022	James Irungu Kamau Vs Wafula Chebukati, IEBC Dispute Resolution Committee
8	IEBC/DR/8/2022	NAIROBI PETITION NO.318 OF 2022	Walter Mongare Vs Wafula Chebukati,IEBC Dispute Resolution Committee
9	IEBC/DR/9/2022	NAIROBI PETITION APPEAL NO.E450 OF 2022	Mogendi Wilson Saiya Vs IEBC,ODM,Willson Mwitha Abed Marao
10	IEBC/DR/10/2022	NAIROBI JUDICIAL REVIEW NO.081 OF 2022	Njilithia Mberia Vs Returning Officer Langatta Constituency,Anthony Maragu Muthoni
11	IEBC/DR/11/2022	KERUGOYA JUDICIAL REVIEW NO.3 OF 2022	Manases Muriithi Macuka Vs Returning Officer Mwea,IEBC Dispute Resolution Committee
12	IEBC/DR/12/2022	KERUGOYA JUDICIAL REVIEW NO.E002 OF 2022	Joseph Muriithi Njoka Vs Returning Officer Gichugu Constituency
13	IEBC/DR/13/2022	NAIROBI JUDICIAL REVIEW NO. E105 OF 2022	Exparte Applicants Vs ODM , IEBC And Kennedy Oyugi Odhaiambo,Returing Officer Ranga Constituency
14	IEBC/DR/14/2022	NAIROBI JUDICIAL REVIEW NO.E102 OF 2022	Geoffrey Namuny Elwa Vs Returning Officer Embakasi East Constituency,ODM And Dispute Resolution Committee
15	IEBC/DR/15/2022	NAIROBI JUDICIAL REVIEW NO.E063 OF 2022	David Njilithia Mberia Vs Returning Oficer Langatta Constituency,ODM & Another
16	IEBC/DR/16/2022	BUNGOMA JUDICIAL REVIEW NO.E004 OF 2022	David Mamali Wanjala Vs Returning Officer Bumula Constituency,IEBC And ODM
17	IEBC/DR/17/2022	MIGORI PETITION NO.319 OF 2022	Samwel Otieno Otieno Vs IEBC Dispute Resolution Committee
18	IEBC/DR/18/2022	KIAMBU JUDICIAL REVIEW NO.02 OF 2022	Paul Karungo Thangwa Vs IEBC Dispute Resolution Committee And Cro Kiambu County
19	IEBC/DR/19/2022	MERU PETITION NO.E008 OF 2022	Hillary Mutuma Thangwa Vs IEBC, Returning Officer North Imenti Constituency
20	IEBC/DR/20/2022	NYAMIRA JUDICIAL REVIEW NO.E003 OF 2022	Zacharia Mogaka Openda Vs IEBC
21	IEBC/DR/21/2022	NAIROBI JUDICIAL REVIEW NO.074 OF 2022	Isaac Aluochier Vs IEBC And Another
22	IEBC/DR/22/2022	VIHIGA JUDICIAL REVIEW NO.2 OF 202	Samuel Idiara Mwigai Vs IEBC & Another
23	IEBC/DR/23/2022	HOMABAY JUDICIAL REVIEW NO.9 OF 2022	Zachary Aseda Omondi Rombo Vs IEBC,ODM, Returning Officer Embakasi West Constituency
24	IEBC/DR/24/2022	NAIROBI JUDICIAL REVIEW NO.E106 OF 2022	Dancan Ochieng Obolon Vs IEBC Dispute Resolution Committee,Returning Officer Embakasi West Constituency

S/NO	REFERENCE NUMBER	COURT CASE NUMBER	PARTIES INVOLVED
25	IEBC/DR/25/2022	NYAMIRA JUDICIAL REVIEW NO.01 OF 2022	Peter Abuga Tengeya Vs IEBC Dispute Resolution Committee,Returning Officer West Mugirango Constituency
26	IEBC/DR/26/2022	NAIROBI JUDICIAL REVIEW NO.E298 OF 2022	Booker Ngesa Omole Vs Benedict Wachira, Communist Party And IEBC
27	IEBC/DR/27/2022	MACHAKOS JUDICIAL REVIEW NO.E003 OF 2022	Gideon Ngewa Kenya & Kisilu Mutisya Vs Wavinya Ndeti,ORPP,KNQA,IEBC
28	IEBC/DR/28/2022	KAKAMEGA JUDICIAL REVIEW NO. E008 OF 2022	David Shimenga Vs IEBC Vs IEBC
29	IEBC/DR/29/2022	KIAMBU JUDICIAL REVIEW NO.03 OF 2022	Duncan Njenga Vs IEBC Vs IEBC
30	IEBC/DR/30/2022	NYAHURURU JUDICIAL REVIEW NO.E005 OF 2022	George Nguri Olgorook Vs Returning Officer Olgorook Constituency, IEBC
31	IEBC/DR/31/2022	NAIROBI JUDICIAL REVIEW NO.E366 OF 2022	David Njilithia Mberia Vs ODM Party And IEBC
32	IEBC/DR/32/2022	NAIROBI CIVIL SUIT NO.E365 OF 2022	Julius Ingansi Benson Vs IEBC, Returning Officer Ruaraka Constituency
33	IEBC/DR/33/2022	HOMABAY PETITION NO.E002 OF 2022	Peter Odimabo Agor Vs IEBC,Returning Officer Kasipul Kabondo Constituency
34	IEBC/DR/34/2022	NAIROBI COURT OF APPEAL NO. E432 OF 2022	Fatuma Adam Hussein Vs Returning Officer Langatta Constituency & Another
High Court Appeals Arising From Dispute Resolution Petitions On Party Primaries 2022 (Dra)			
1	IEBC/DRA/1/2022	NAIROBI DISPUTE TRIBUAL NO.25 OF 2022	Peter Odhiambo Agoro Vs Alice Neke Wingi,IEBC ODM And Another
2	IEBC/DRA/2/2022	NAIROBI HIGH COURT APPEAL NO.314 OF 2022	Deka Ali Khala Vs National Elections Board,ODM IEBC & Another
3	IEBC/DRA/3/2022	NAKURU CIVIL APPEAL NO.E063 OF 2022	Susan Nyambura Njuguna Vs John Karanja Gachingiri,UDA And IEBC
4	IEBC/DRA/4/2022	GARISSA PETITION APPEAL NO.7B OF 2022	Hon.Musdaf Hussein Abdullahi Vs ODM National Elections Board, ODM, Hon.Hassan Noor Mohamed Ali And IEBC
5	IEBC/DRA/5/2022	KAKAMEGA HIGH COURT APPEAL NO.E002 OF 2022	Erick Nafula Whyonyi Vs Gasper Mafutu,Dap-Kenya And IEBC
6	IEBC/DRA/6/2022	KAKAMEGA HIGH COURT APPEAL NO.E001OF 2022	David Kubasu Shimenga Vs Amani National Congress Party,National Elections Board And Ramadhan Butichi
7	IEBC/DRA/7/2022	NAIROBI HIGH COURT APPEAL NO.E003 OF 2022	Maurice Otieno Gari Vs IEBC, Returning Officer Langatta Constituency And Another
8	IEBC/DRA/8/2022	KISUMU HIGH COURT CIVIL APPEAL NO.45 OF 2022	John Ombena Gare Vs ODM National Elections Board, IEBC And Another
9	IEBC/DRA/9/2022	NAIROBI HIGH COURT APPEAL NO. 259 OF 2022	John Andiwo Mwai Vs ODM Elections Board,Returnign Officer Bondo Constituency And IEBC
10	IEBC/DRA/10/200	NAKURU HIGH COURT APPEAL NO.072 OF 2022	John Kariuki Kaniaru Vs Hon.Charity Kathambi Chepkwony And 3 Others

S/NO	REFERENCE NUMBER	COURT CASE NUMBER	PARTIES INVOLVED
11	IEBC/DRA/11/2022	NAIROBI COURT OF APPEAL NO.341 OF 2022	Mohamed Adan Mohamed Vs Wiper Democratic Party And IEBC
12	IEBC/DRA/12/2022	NAIORBI HIGH COURT APEAL NO.E001 OF 2022	Marcos Kithuku Makau Vs Mohamed Adan Mohamed
13	IEBC/DRA/13/2022	KISUMU HIGH COURT APPEAL NO.075 OF 2022	Amani National Congress & Another Vs David Kubusa Shimenga And IEBC
14	IEBC.DRA/14/2022	KAKAMEGA PETITION APPEAL NO.E004 OF 2022	Zanga Boniface Elisha Vs Johnstone Alusola Makabwa And IEBC
15	IEBC/DRA/15/2022	NAIROBI CIVIL APPEAL NO.E338 OF 2022	Jemnyango Moses Kamalik Vs IEBC & Another
16	IEBC/DRA/16/2022	KISUMU APPEAL NO.E034 OF 2022	Zakayo Ongondo Okumu Vs IEBC And ODM
17	IEBC/DRA/17/2022	KISUMU COURT OF APPEAL NO.E003 OF 2022	ODM Elections Board Vs IEBC,John Ombewa Gare,Trufosa Osewa Odinga And IEBC
18	IEBC/DRA/18/2022	KISUMU COURT OF APPEAL NO.E044 OF 2022(CONSOLIDATED WITH KISUMU APPEAL NO.E045 OF 2022)	ODM Elections Board Vs IEBC,John Ombewa Gare,Trufosa Osewa Odinga And IEBC
19	IEBC/DRA/19/2022	KAJIADO APPEAL NO.E001 OF 2022	Abdisalam Hassan Abdi Vs IEBC
20	IEBC/DRA/20/2022	SIAYA HIGH COURT APPEAL NO. 29 OF 2022	Christopher Odhiambo Kobino Vs Returning Officer Alego Usonga Constituency
21	IEBC/DRA/21/2022	NAIROBI HIGH COURT APPEAL NO.E413 OF 2022-	Shadrack Machanje Numunyu Vs Joseph Ouma Ndonji & Another
22	IEBC/DRA/22/2022	KISUMU COURT OF APPEAL NO.	Loice Akoth Kawaka & Another Vs IEBC & Another
23	IEBC/DRA/23/2022	NAIROBI COURT OF APPEAL NO.E389 OF 2022	Nick Evance Okoth Ochola Vs Ted Marvin Odhiambo,ODM Board
24	IEBC/DRA/24/2022	NAIROBI APPEAL NO.E414 OF 2022	Catherine Muuma Vs Joseph Ouma Ndonji & Another
25	IEBC/DRA/25/2022	NAIROBI COURT OF APPEAL NO.E007 OF 2022	Marcos Kithuku Makau Vs Mohamed Adan Mohamed
26	IEBC/DRA/26/2022	NAIROBI JUDICIAL REVIEW NO.E298 OF 2022	Booker Ngesa Omole Vs Benedict Wachira, Communist Party And IEBC
27	IEBC/DRA/27/2022	KISUMU COURT OF APPEAL NO.E904 OF 2022	Nicholas Ouma Mbago Vs Nicholas Oluoch And IEBC
Judicial Review Cases 2021 To 2022 Fy			
1	IEBC/JR/MISC/5/2021	NAIROBI HC JR NO. E102 OF 2021	Impala Club Vs Registrar Of Societies ,Hon.Ag Maria Goretti & IEBC
2	IEBC/JR/MISC/6/2021	BUNGOMA JR MISC NO. E054 OF 2021	Duke Omwenga Vs IEBC
3	IEBC/JR/MISC/7/2021	NAIROBI HC JR NO. E134 OF 2021	Smartic International Holding B.V Vs Ppoa Review Board,IEBC And Reisk Africa Innovitis Limited
4	IEBC/JR/MISC/8/2021	NAIROBI JR MO.E033 OF 2021	Khelef Khalifa Vs IEBC,Hon.Raila Odinga And Stephen Kalonzo Musyoka

S/NO	REFERENCE NUMBER	COURT CASE NUMBER	PARTIES INVOLVED
5	IEBC/JR/MISC/9/2021	NAIROBI JR NO.E186 OF 2021	Scanad Kenya Ltd Vs IEBC
1	IEBC/JR/MISC/1/2022	NAIROBI JR APPLN NO.E69 OF 2022	Ami Odiero Bakker & 54 Others Vs IEBC,Hon.Ag
2	IEBC/JR/MISC/2/2022	NAIROBI JR APPLN NO.E070 OF 2022	Elijah Njore Njoroge Karuria & Another Vs IEBC And Hon.Ag
3	IEBC/JR/MISC/3/2022	NAIROBI JR MISC. NO.048 OF 2022	Mahat Rashid Hassan Vs Rpp,Maendeleo Chap Chap,Azimio La Umoja And IEBC
4	IEBC/JR/MISC/4/2022	KISUMU JR MISC. NO. E001 OF 2022	Michael Ojala Nyangi Vs Hezron Okoth Onditi,ODM Party And IEBC
5	IEBC/JR/MISC/5/2022	NAIROBI JR MISC NO. E071 OF 2022(Adrian Kamotho Njenga (Two Third Gender) Vs IEBC
6	IEBC/JR/MISC/6/2022	GITHUNGURI JR MISC NO. 12 OF OF 2022	Peter Maingi Kungu Vs IEBC
7	IEBC/JR/MISC/7/2022	NYERI JR MISC NO. E004 OF 2022	Irungu Mwangi Vs IEBC
8	IEBC/JR/MISC/8/2022	NAIROBI JR MISC NO. E060 OF 2022	Faith Wairimi Ngigi Vs IEBC
9	IEB/JR/MISC/9/2022	NAIROBI JR MISC NO. E057 OF 2022	Johnson Sakaja Arthur Vs Commission For University Education,UDA Nad IEBC
10	IEBC/JR/ MISC/10/2022	NAIROBI JR MISC.090 OF 2022	Stephen Omodia Emusukuti Vs IEBC Disputee Resolution Committee,Returning Officer Embakasi East And IEBC
11	IEBC/JR/MISC/11/2022	BUSIA JR MISC NO. E002 OF 2022	George Makhayaka Busera Vs IEBC
12	IEBC/JR/MISC/12/2022	MACHAKOS JR MISC. NO. 3 OF 2022	Gideon Ngewa Kenyi & Kisilu Mutisya Vs Wavinya Ndeti,IEBC, Dpp And Another
13	JIEBC/JR/MISC/13/2022	NAIROBI JR MISC NO. E84 OF 2022	Hassan Abi Ali Vs IEBC
14	IEBC/JR/MISC/14/2022	NAKURU JR MISC NO. E008 OF 2022	Republic Of Kenya Vs Government Printer, Lee Kinyajui, Susan Kihika And Another
15	IEBC/JR/MISC/15/2022	BUNGOMA PETITION NO. E006 OF 2022	Enosh Momanyi Isoe Vs IEBC Returning Officer Webuye West Constituency
Public Procurement Review Board			
1	PPOA/1/2021	PPARB APPLICATION NO. 107 OF 2021	Risk Africa Innovatis Ltd Vs Accounting Officer-IEBC
2	PPOA/2/2021	PPARB APPLICATION NO. 132 OF 2021	Negoti
3	PPOA/3/2021	PPARB APPLICATION NO. 133 OF 2021	Tall Security Print Ltd Vs Accounting Officer -IEBC
4	PPOA/4/2021	PPARB APPLICATION NO. 129 OF 2021	Shailesh T/A Africa Infrastructure Development Vs Accounting Officer IEBC, Inform Lykos (Hellas) S.A
5	PPOA/5/2021	PPARB APPLICATION NO. 130 OF 2021	Unprint Adivision Of Insidedeta Ltd(South) Ltd Vs Accounting Officer-IEBC

S/NO	REFERENCE NUMBER	COURT CASE NUMBER	PARTIES INVOLVED
6	PPOA/6/2021	PPARB APPLICATION NO. 117 OF 2021-	Smartmatic International Holdings B.V. Vs IEBC
7	PPOA/1/2022	PPARB APPLICATION NO. 66 OF 2022	Marioni Enterprises Limited Vs Accounting Officer IEBC, County Election Manager IEBC Baringo County, Longonot Transporters And Car Lease Services
8	PPOA/2/2022	PPARB APPLICATION NO. 56 OF 2022	Acacia Satlink Limited Vs Accounting Officer IEBC And M/S Osta Tech Limited
Civil Suits			
1	IEBC/CS/1/2021	LODWAR CIVIL SUIT NO. 007 OF 2021	Jacob Kamol Billy Esekon & 77 Others Vs Turkana County Drivers Associations, IEBC And Ministry Of Health County Government Of Turkana, IEBC
2	IEBC/CS/1/2022	NAKURU CIVIL SUIT NO. E006 OF 2022	Thomas Owino Onyango & 7 Others Vs IEBC & Another
3	IEBC/CS/2/2022	NAIROBI CIVIL SUIT NO. E1493 OF 2022	Far East Connection Limited Vs IEBC
4	IEBC/CS/3/2022	NAIROBI CIVIL SUIT NO. 2587 OF 2022	Soloh World Wide International Enterprises Limited Vs IEBC
5	IEBC/CS/4/2022	NAKURU CIVIL SUIT NO. E579 OF 2022	Julius Ingansi Benson Vs IEBC, Returning Officer Ruaraka Constituency
Industrial Court Matters 2021-2022fy			
1	IEBC/IC/1/2021	NAIROBI EMPLOYMENT AND LABOUR COURT NO. E208 OF 2021	Julius Wanyama Kariuki Vs IEBC & Hon.Ag
2	IEBC/IC/1/2022	NAIROBI EMPLOYMENT AND LABOUR COURT NO. 12 OF 2022 (FORMERLY NAIROBI PETITION NO. E008 OF 2022)	Okiya Omtatah Okoiti Vs IEBC And Ho.Ag
3	IEBC/IC/2/2022	NAIROBI EMPLOYMENT & LABOUR COURT NO. E002 OF 2022	Adrian Kamaotho Vs IEBC & Ho.Ag
4	IEBC/IC/3/2022	KISUMU EMPLOYMENT & LABOUR COURT NO. E025 OF 2022	Mottanya Charles Nyandusi Vs IEBC & Hon.Ag
5	IEBC/IC/4/2022	NAIROBI EMPLOYMENT & LABOUR COURT NO. 35 OF 2022	Mariam Abdi Mohamud Vs IEBC, Wajir County Assembly Service Board

Annex 2: Cases Investigated

S/NO	COUNTY	CONSTITUENCY	SUBJET
1.	Kiambu	Muguga County Assembly Ward and Kiambaa	Investigation on allegation of voter bribery during Kiamba MNA and Muguga CAW MCA By-elections.
2.	Tharaka Nithi	Tharaka	Investigation on theft of BVR laptops in Tharaka Constituency office.
3.	Meru	Imenti Central	Investigation on objection of nomination of candidates in Kiagu County Assembly Ward by-election.
4.	Kiambu	Juja	Follow up investigation on Juja MNA by-election incidences
5.	Nairobi	HQ	Investigation to false allegation by Hon. Moses Kuria on his social media platform.
6.	Kisumu	Warehouse	Investigation on the theft of EVID laptops at Kisumu County warehouse.
7.	Kakamega	Khwisero	Investigation of a complaint by a police officer in Khwisero Constituency for non-payment of security allowances.
8.	Kakamega	Likuyani	Investigation on the data of Register of Voters for Likuyani Constituency found in possession of a civilian arrested in Juja Town.
9.	Homa Bay	Rachuonyo	Investigation into breakage of Rachuonyo Constituency office where BVR laptops were stolen.
10.	Makueni	Kibwezi West	Investigation on a fatal traffic road accident involving Commission motor vehicle.
11.	Kisii	Bomachoge Borabu	Investigation of an assault to Voter Registration Clerks and malicious damage to Commission property in Bomachoge Borabu Constituency.
12.	Kisumu	Muhoroni	Investigation on the theft of Biometric Voter Registration (BVR) Kit in Chemilil CAW.
13.	Busia	Matayos	Investigation of alleged mass voter transfers in Matayos Constituency.
14.	Muranga	Kandara	Investigation of alleged Mass voter transfer from Kigumo Constituency to Kandara Constituency.
15.	Kakamega	County HQ	Investigation of a complaint for non-payment of transport allowance for voter registration clerks in Kakamega County during ECVR 1.
16.	Migori	Suna East	Investigation on a public complaint against one Clifford Obunga Jobando an aspirant for MCA seat in God Jope County Assembly Ward in Migori County.
17.	Kakamega	Malava	Investigation on a petition against Hon. Moses Malulu Ijendi MNA Malava Constituency for electoral and political violence during funerals in Malava Constituency.

S/NO	COUNTY	CONSTITUENCY	SUBJET
18.	Taita Taveta	All constituencies	Investigation on a petition of a voter registration exercise 2021 filed by a voter in Taita Taveta County.
19.	Vihiga	Vihiga	Investigation to Hon. Sabina Wanjiru Chege utterances in a public rally within Vihiga County.
20.	Nairobi	HQ	Investigation on Hon. Kuria Moses Kiarie utterances during UDA National Delegates Convention at Kasarani Gymnasium Arena in Nairobi County.
21.	Nairobi	HQ	Investigation on H.E Dr. William Samoei Ruto speech while speaking in Maryland in the United State of America.
22.	Kilifi	Kilifi South	Investigation on allegations of unfair dismissal of a voter registration clerk
23.	Uasin Gishu	Kesses	Investigation for violation of work ethics by County Election Manager Uasin Gishu.
24.	Kisii	South Mugirango	Investigation on arrest of voter registration Clerks by DCI officers from Gucha South Sub-County.
25.	Kisii	Nyaribari Chahe	Investigation on a complaint against Nyaribari Chache Constituency Registration officer on gazettement of new registration centre
26.	Taita Taveta	Mwatate	Investigation on electoral offences, breach of the Electoral code of conduct by Mr. Peter Shake MNA Aspirant in Mwatate Constituency
27.	Taita Taveta	Taveta	Investigation on complaint against Taveta Constituency Election Coordinator on mass voter transfer.
28.	Nairobi	HQ	Confidential Investigation
29.	Nairobi	HQ	Investigation into a newspaper publication profiling Commission staff.
30.	Marsabit	County HQ	Investigations on fraudulent transactions in Marsabit County KCB account by the accountant late Ezekiel Muiruri.
31.	Narok	Narok West	Investigation on political violence perpetrated by supporters of Azimio One Kenya Alliance and Kenya Kwanza Gubernatorial candidates in Narok County.
32.	Kakamega	Navakholo	Investigation of a complaint by Hon. Emanuel Wangwe MNA Navakholo Constituency.
33.	Nairobi	National Warehouse	Investigation on the arrest of a casual employee found in possession of Commission flash disks and

S/NO	COUNTY	CONSTITUENCY	SUBJET
			SD cards.
34.	Nairobi	HQ	Investigation on status update on aspirants' compliance with Chapter Six of the Constitution of Kenya, 2010.
35.	Garissa/ Wajir	Balambala/ Eldas	Preliminary investigation on illegal voter transfers and irregular voters registration.

Annex 3: Dispute resolution Committee

No.	COMPLAINT	DECISION DELIVERED
1.	IEBC/DRC/1/2022 Hon. Mwangi Wa Iria V Chairperson IEBC	Matter marked as withdrawn
2.	IEBC/DRC/08/2022 Pauline Muthoni Kahihu Complainant Vs. The Returning Officer, Kikuyu Constituency	The Complaint was dismissed. The Committee upheld the decision of the Returning Officer not to accept the nomination papers of the Complainant to run for the position of Member of National Assembly for Kikuyu Constituency. No orders as to costs.
3.	IEBC/DRC/11/2022 Simon Mburu Njuguna v R.O, Kikuyu Constituency	Complaint withdrawn with no orders as to costs by the Complainant.
4.	IEBC/DRC/CRGE/13/2022 Douglas Maraga Mang'era -Vs- The Nairobi County Returning Officer	Complaint dismissed with no orders as to costs
5.	IEBC/DRC/14/2022 Christine Ndungwa Kiiro v R.O. Kaiti Constituency	Complaint was dismissed with no orders as to costs and the decision of the Returning Officer upheld.
6.	IEBC/DRC/CRGE/17/2022 Thomas Mutisya Musau -Vs- The Returning Officer, Kaiti Constituency	Decision of RO disqualifying Complainant revoked. Complainant to resubmit nomination papers within 48 hours.
7.	IEBC/DRC/18/2022 Marcus Mutua Muluvi & Another v Millitonic Mwendwa Kimanzi Kitute & Another	Complaint was dismissed with no orders as to costs and the decision of the Returning Officer upheld.
8.	IEBC/DRC/CRGE/25/2022 Ruth Akumu Oyombe -Vs- Returning Officer, Kisumu West Constituency	Dismissed for want of prosecution.
9.	IEBC/DRC/26/2022 Belmy Aruda Kipruto Vs. R.O Kisumu East Constituency	Complaint dismissed with no orders as to costs
10.	IEBC/DRC/36/2022 Philip Ojwando Abour Vs. R.O Nairobi County	Complaint Allowed.
11.	IEBC/DRC/42/2022 Cyprian Odote Aende Vs. R.O Embakasi Constituency	Complaint dismissed with no orders as to costs. RO's decision upheld
12.	IEBC/DRC/43/2022 Raymond Getange Ogeto Vs. R.O Changamwe Constituency	Matter marked as withdrawn
13.	IEBC/DRC/44/2022 Macmillan Nyange Mwawaza Vs. R. O Voi Constituency	Complaint dismissed with no orders as to costs. RO's decision upheld
14.	IEBC/DRC/46/2022 Raymond Kahindie Kipkosgei	Complaint dismissed. Decision of the Respondent rejecting the nomination of the Complainant to

No.	COMPLAINT	DECISION DELIVERED
	Vs. Returning Officer, Turbo Constituency	contest for the position of Member of National Assembly Turbo Constituency is upheld. No costs awarded.
15.	IEBC/DRC/49/2022 Mike Nyamai Nguniko Vs. The Returning Officer, Kitui Rural Constituency	Complaint dismissed. The decision of the Respondent rejecting the nomination of the Complainant to contest for the seat of Member of National Assembly, Kitui Rural Constituency is upheld. No costs awarded.
16.	IEBC/DRC/55/2022 Akidah Ingolan Eloilo Vs. The Returning Officer, Turkana West Constituency	Complaint allowed. The decision of the Respondent declining to clear him the Complainant is revoked. The Complainant to present his documents, being the Complainant's Certification of Symbol issued by the ORPP and his Independent Candidate Clearance Form to IEBC Headquarters to have the same stamped and his details entered in the IEBC Candidate Registration Management system. The Complainant to present himself before the Returning Officer, Turkana West Constituency within 72 hours from the date of this Decision for clearance. No Orders as to costs.
17.	IEBC/DRC/CRGE/62/2022 Gaitho Francis Nganga Vs Returning Officer, Thika Town Constituency	Complaint dismissed with no orders as to costs
18.	IEBC/DRC/63/ 2022 Stephen Owoko Oganga Vs. The Presidential Returning Officer	The Complaint was dismissed and the decision of the Returning Officer for presidential elections rejecting the nomination application by the Complainant to run for the position of president of the Republic of Kenya upheld. No costs awarded
19.	IEBC/DRC/CRGE/64/2022 Onesmus Mwiathi Mwirichia -Vs- The County Returning Officer, Tharaka Nithi	Complaint dismissed with no orders as to costs
20.	IEBC/DRC/65/2022 James Irungu Kamau v Wafula Chebukati, Presidential Returning Officer	Complaint was dismissed with no orders as to costs and the decision of the Presidential Returning Officer upheld.
21.	IEBC/DRC/72/2022 Robert Munyui Kinyanjui v R.O, Kikuyu Constituency	Complaint was allowed with no orders as to costs and the decision of the Returning Officer revoked.
22.	IEBC/DRC/CRGE/87/2022 June Juliet Munyeki Vs Wafula Chebukati	Complaint dismissed with no orders as to costs.
23.	IEBC/DRC/88/2022	Dismissed for want of prosecution

No.	COMPLAINT	DECISION DELIVERED
	Idris Adan Wako Vs. Ibrahim Guyo & 2 Others	
24.	IEBC/DRC/93/2022 Elizabeth Lydia Lubalo v. R. O, Mombasa County	Complaint dismissed with no orders as to costs. RO's decision upheld
25.	IEBC/DRC/96/2022 Joseph Arung' Okweso Vs. R.O Rarieda Constituency	Complaint Allowed.
26.	IEBC/DRC/97/2022 Nicholas Ouma Mbago Vs. The Returning Officer, Rongo Constituency	The Complaint was allowed. The clearance of Nelson Oluoch Onyango as the Jubilee Candidate for Member of National Assembly seat for Rongo Constituency revoked. The Respondent directed to effect the same immediately. No costs awarded.
27.	IEBC/DRC/98/2022 Samson Marona & 3 Others Vs. R. O Kisii County & Another	Dismissed for want of jurisdiction
28.	IEBC/DRC/102/2022 Mohamed Abdi Farah -Vs- Alhamdu Siyad Muhumed	The Complaint was dismissed for want of prosecution with no orders as to costs.
29.	IEBC/DRC/104/2022 James Mbugua Maina v R.O, Thika Constituency	The Complaint was allowed with no orders as to costs and the decision of the Returning Officer was revoked.
30.	IEBC/DRC/CRGE/105/2022 George Bush -Vs- The Nairobi County Returning Officer & Polycarp Igathe.	Complaint dismissed with no order as to costs.
31.	IEBC/DRC/109/2022 David Opala Ochieng Vs. Returning Officer, Alego Usonga Constituency	Complaint dismissed. The decision of the Returning Officer, Alego Usonga Constituency rejecting the nomination application by Complainant to run for a Member of National Assembly seat in Alego Usonga Constituency, Siaya County upheld. No orders as to costs.
32.	IEBC/DRC/115/2022 Edna Ogilo Chienjo Vs. E.O Emabkasi West Constituency	Dismissed for want of Prosecution (Complainant failed to Appear)

No.	COMPLAINT	DECISION DELIVERED
33.	IEBC/DRC/119/2022 Julius Inganji Benson Vs. The Returning Officer, Ruaraka Constituency	Complaint dismissed. The decision of the Returning Officer, Ruaraka Constituency rejecting the nomination application by Complainant to run for a Member of County Assembly seat in Lucky Summer Ward, Ruaraka Constituency, Nairobi County upheld. No orders as to costs.
34.	IEBC/DRC/121/2022 Constance Munanie Mutua Vs Returning Officer-Kibwezi West Constituency	The Complaint was allowed. The decision of the Respondent declining to register the Complainant set aside; The Complainant directed to present herself before the Returning Officer, Kibwezi West Constituency within 48hours from the date of this Decision for processing of her nomination papers. No costs awarded.
35.	IEBC/DRC/CRGE/124/2022 Wiper Democratic Movement -Vs- Returning Officer, Mombasa County	Withdrawn with no order as to costs.
36.	IEBC/DRC/125/2022 Harison Koina Orutwa Vs. The Returning Officer, Bomachoge Borabu Constituency	Complaint Dismissed. The decision of the Returning Officer, Bomachoge Borabu Constituency rejecting the nomination application by Complainant to run for a Member of National Assembly seat, Kisii County upheld. No orders as to costs.
37.	IEBC/DRC/127/2022 Mike Sonko Mbuvi Gideon Kioko Versus Returning Officer, Mombasa County	The Complaint was dismissed, the decision of the Returning Officer, Mombasa County rejecting the nomination application by the Complainant to run for the position of Governor Mombasa County was upheld. No costs awarded.
38.	IEBC/DRC/128/2022 Robert Kennedy Okong'o v C.R.O, Migori County	Complaint was dismissed with no orders as to costs and the decision of the Returning Officer upheld.
39.	IEBC/DRC/131/2022 Abdullahi Mamo Sode Vs. R.O Ruaraka Constituency	Complaint dismissed with no orders as to costs
40.	IEBC/DRC/132/2022 Felix Ochieng Omollo Vs. The Returning Officer, Ruaraka kConstituency	The Complaint was dismissed, the decision of the Returning Officer, Korogocho Ward in Nairobi County not to accept the nomination papers of the Complainant to run for the position of Member of County Assembly for Kikuyu Constituency upheld. No orders as to costs.

No.	COMPLAINT	DECISION DELIVERED
41.	IEBC/DRC/134/2022 Collins Nyongesa v R.O, Dagoretti North Constituency	The Complaint was withdrawn by the Complainant before the Committee.
42.	IEBC/DRC/135/2022 Siat Kediye Salat Vs Returning Officer Ijara Constituency	Complaint dismissed. The Committee recommends that further investigations be conducted on the matter, particularly the relationship between the Complainant and the Respondent and what transpired on 31 st May, 2022. No orders as to costs.
43.	IEBC/DRC/CRGE/136/2022 Wiper Democratic Movement -Vs- Returning Officer, Mombasa County & Others	Complainant allowed to present an alternative nominee for possible registration as candidate.
44.	IEBC/DRC/137/2022 Abdirizak Osman v R.O, Wajir South Constituency & Another	The Complaint was withdrawn albeit with terms. The decision of the Returning Officer was revoked.
45.	IEBC/DRC/139/2022 Isaya Ogega Ontita Vs. Returning Officer Starehe Constituency	Complaint dismissed for want of prosecution with no Orders as to costs.
46.	IEBC/DRC/144/2022 Paul Kiprono Korir v Rotich Ernest Kipkemoi & R.O, Konoin Constituency	The Complaint was withdrawn in writing by the Complainant.
47.	IEBC/DRC/145/2022 Kennedy Kamunyu v R.O, Tharaka Constituency	Complaint was allowed with no orders as to costs and the decision of the Returning Officer revoked.
48.	IEBC/DRC/147/2022 Joash Emori Maangi -Vs- County Returning Officer- Kisii County	The Complaint marked as withdrawn with no orders as to costs.
49.	IEBC/DRC/155/2022 Katiezo Christopher v R.O, Likuyani Constituency	Complaint was dismissed with no orders as to costs and the decision of the Returning Officer upheld.
50.	IEBC/DRC/157/2022 Michael Ritho Gakure v R.O Limuru Constituency	Complaint was dismissed with no orders as to costs and the decision of the Returning Officer upheld.
51.	IEBC/DRC/CRGE/161/2022 Fatma Adan Hussein -Vs- Returning Officer, Lang'ata Constituency	Complaint dismissed with no orders as to costs
52.	IEBC/DRC/CRGE/167/2022	Complaint dismissed with no orders as to costs

No.	COMPLAINT	DECISION DELIVERED
	Christphers Wahome Muthoni -Vs- The Returning Officer, Starehe Constituency	
53.	IEBC/DRC/172/2022 Juma Akida v RO, Lurambi Constituency	Complaint Allowed. Complainant to resubmit nomination for clearance within 48 hours of decision for consideration of RO
54.	IEBC/DRC/173/2022 John Owiti Wasike Vs The Returning Officer, Matungu Constituency	Complaint dismissed. The decision of the Respondent rejecting the nomination of the Complainant upheld. No costs awarded.
55.	IEBC/DRC/175/2022 Ibrahim Said Balacho Vs. R.O Isiolo County	Complaint dismissed with no orders as to costs. RO's decision upheld
56.	IEBC/DRC/176/2022 James Munykenya Vs. R.O Embakasi South Constituency	Complaint dismissed with no orders as to costs. RO's decision upheld
57.	IEBC/DRC/178/2022 Juma Hassan Mwachatamu vs R.O Nyali Constituency	Complaint dismissed with no orders as to costs. RO's decision upheld
58.	IEBC/DRC/182/2022 Sylvester Mackeleuse Musudi Vs. Returning Officer, Butula Constituency	Complaint dismissed. The Committee upheld the decision of the Respondent rejecting the nomination application by the Complainant to contest for the position of a Member of National Assembly Marach West Ward, Butula Constituency. No costs awarded.
59.	IEBC/DRC/183/2022 Samwel Idaria Mwigai Vs. R.O Vihiga County & 2 Others	Complaint dismissed with no orders as to costs. RO's decision upheld
60.	IEBC/DRC/195/2022 Abdirahman Salat Muhumed v R.O, Ijara Constituency	Complaint was dismissed with no orders as to costs and the decision of the Returning Officer upheld.
61.	IEBC/DRC/202/2022 Nyalia Salmon Otieno v R.O, Gem Constituency	The Complaint was withdrawn in writing by the Complainant.
62.	IEBC/DRC/203/2022 Kennedy Mwangi Wairimu Vs. R.O Starehe Constituency	Complaint dismissed with no orders as to costs.
63.	IEBC/DRC/204/2022 Joseph Ouma Ndonji V Shadrack Machanje Namunyu & Others	Complaint was allowed to the extent that the RO's decision to clear the Candidate is revoked. Found the Complainant not eligible for nomination on account of PPDT. The Party allowed to nominate an alternative candidate within 72 hours to undergo clearance process before the RO.
64.	IEBC/DRC/CRGE/208/2022	Complainant allowed to resubmit nomination

No.	COMPLAINT	DECISION DELIVERED
	Cornelius Oramisi Omuse -Vs- Returning Officer, Teso North Constituency	papers within 48 hours.
65.	IEBC/DRC/209/2022 Kitur K. Philip -Vs- Returning Officer- Bureti Constituency	Complaint dismissed. The decision of the Returning Officer, Bureti Constituency rejecting the nomination application by Complainant to run for a Member of County Assembly seat for Kapkatet Ward in Kericho County upheld. No costs awarded.
66.	IEBC/DRC/227/2022 Peter Kihui Njoroge Vs. Kiambu Township Ward, Kiambu Constituency	Complaint dismissed with no orders as to costs. RO's decision upheld
67.	IEBC/DRC/229/2022 Joseph Kahira Wambui v R.O, Thika Town Constituency	The Complaint was allowed with no orders as to costs and the decision of the Returning Officer was revoked.
68.	IEBC/DRC/232/2022 Francis Oduor Amolo v Bernard Ochieng Ogutu & 2 Others	The Complaint was dismissed with no orders as to costs and the decision of the Returning Officer was revoked.
69.	IEBC/DRC/234/2022 Bob Owenga Okiya Vs. Returning Officer, Luanda Constituency	Complaint allowed. The decision of the Respondent declining to register the Complainant is hereby set aside; The relevant department at IEBC directed to enter the name and details of the Complainant into the Candidate Registration Management System within 12 hours from the date of the Decision to facilitate his clearance; The Complainant allowed to present herself before the Returning Officer, Luanda Constituency within 72hours from the date of this Decision for processing of her nomination papers. No costs awarded.
70.	IEBC/DRC/236/2022 Antony Mutembei Julius v R.O, Igembe South Constituency	Complaint was dismissed with no orders as to costs and the decision of the Returning Officer upheld.
71.	IEBC/DRC/238/2022 Kirum Joseph Kamau V Samson Wanjama Mugo	Dismissed for lack of jurisdiction.
72.	IEBC/DRC/239/2022 Jeremiah Kiwoi Vs. Granton Graham Samboja & 3 Others	Complaint dismissed with no orders as to costs. RO's decision upheld
73.	IEBC/DRC/CRGE/240/2022 Elly Kibet Kolum -Vs- Returning Officer, Tindiret Constituency	Complaint dismissed with no orders as to costs
74.	IEBC/DRC/CRGE/243/2022 Joseph Muriithi Njoka -Vs-The Returning Officer, Gichugu Constituency & 2 Others	Complaint dismissed with no orders as to costs

No.	COMPLAINT	DECISION DELIVERED
75.	IEBC/DRC/CRGE/246/2022 Sylvester Hannington Wauye -Vs- Returning Officer, Ugenya Constituency & IEBC.	Decision of the RO rejecting the Complainant's nomination papers revoked. Complainant allowed to resubmit his nomination papers within 48 hours of the decision.
76.	IEBC/DRC/CRGE/248/2022 Charles Wachira Kamau Vs. The Returning Officer, Nairobi County	The Complaint was dismissed for want of prosecution. No orders as to costs.
77.	IEBC/DRC/CRGE/250/2022 George Abuogo Owino -Vs- Returning Officer, Kisumu East	Complaint dismissed with no orders as to costs
78.	IEBC/DRC/254/2022 Abdirahman Tawane Abdi Vs. R. O Garissa Township Constituency	Compliant Allowed. Decision of RO revoked
79.	IEBC/DRC/260/2022 Mohamed Adan Mohamed Vs. Returning Officer, Embakasi Constituency	The Complaint was dismissed. The decision of the Respondent to clear the Marcos Kithuku Makau to contest for the seat of Member of County Assembly in Kwa Njenga Ward, Nairobi County upheld.
80.	IEBC/DRC/CRGE/263/2022 Joel Wekesa Simiyu -Vs- Returning Officer, Kwanza Constituency	Complaint dismissed with no orders as to costs
81.	IEBC/DRC/266/2022 Moses Gitonga M'mukiri V Ro, Igembe South Constituency	Dismissed for want of Prosecution
82.	IEBC/DRC/CRGE/267/2022 Nasra Nasirumbi Mwalimu -Vs- Returning Officer, Garsen Constituency.	Complaint dismissed with no orders as to costs.
83.	IEBC/DRC/CRGE/268/2022 Adhola Moses Otieno -Vs- The Returning Officer, Rarieda Constituency	Complaint dismissed with no order as to costs.
84.	IEBC/DRC/CRGE/269/2022 Ahmed Abdirashid Abdikadir -Vs- Ahmed Abdullahi Jiir, Adan Ali Mohamed, & The County Returning Officer, Wajir	Complaint dismissed with no orders as to costs
85.	IEBC/DRC/270/2022 Abdinoor Ali Ahmed v Mohamed Ibrahim Elmi alias Mohamed Fai & 3 Others	Complaint was dismissed with no orders as to costs and the decision of the Returning Officer upheld.
86.	IEBC/DRC/CRGE/273/2022 Lydia Jenny Katuku Muthusi -Vs- Returning Officer, Makueni	Complaint dismissed with no orders as to costs.

No.	COMPLAINT	DECISION DELIVERED
	Constituency	
87.	IEBC/DRC/CRGE/274/2022 Luka Ruga Wamuyu -Vs- Returning Officer, Gatundu North Constituency.	Complaint dismissed for want of prosecution with no orders as to costs.
88.	IEBC/DRC/275/2022 Stephen Kinyua Kabui v R.O, Kirinyaga Central Constituency	Complaint was dismissed with no orders as to costs and the decision of the Returning Officer upheld.
89.	IEBC/DRC/278/2022 Shem Omweri Nyangweso v R.O, South Mugirango Constituency	Complaint was dismissed with no orders as to costs.
90.	IEBC/DRC/CRGE/279/2022 Mohamed Abdi Mohamed -Vs- The Returning Officer, Isiolo North Constituency	Complaint dismissed with no orders as to costs.
91.	IEBC/DRC/CRGE/281/2022 Samuel Lekae -Vs- Returning Officer, Baringo South Constituency & 2 others.	Complaint withdrawn with no orders as to costs.
92.	IEBC/DRC/282/2022 Kevin Muthoni Ndwiga V RO, Manyatta Constituency	Dismissed for want of Prosecution
93.	IEBC/DRC/283/2022 Willington Mwamburi Kilongi v R.O, Voi Constituency	Complaint was dismissed with no orders as to costs and the decision of the Returning Officer upheld.
94.	IEBC/DRC/CRGE/285/2022 Joseph Kobie Mughenyu -Vs- The Returning Officer, Mwatate Constituency	Complaint dismissed with no order as to costs.
95.	IEBC/DRC/286/2022 Zuber Nahaji Hassan v R.O, Kitutu Chache South Constituency	Complaint was dismissed with no orders as to costs and the decision of the Returning Officer upheld.
96.	IEBC/DRC/CRGE/290/2022 Wilson Nashon Ogwang Ogoya -Vs- Returning Officer, Kisumu East	Complaint dismissed with no orders as to costs
97.	IEBC/DRC/291/2022 James Mwangi Gacheche v R.O, Ol-jor-orong Constituency	The Complaint was allowed with no orders as to costs and the decision of the Returning Officer was revoked.
98.	IEBC/DRC/292/2022 Abdulrahman Charo Abdul v R.O, Kisauni Constituency	The Complainant agreed to administrative guidance regarding the issues raised in the Complaint.

No.	COMPLAINT	DECISION DELIVERED
99.	IEBC/DRC/CRGE/293/2022 Mary Mwendu Mutinda -Vs- The Returning Officer, Nyatike Constituency & Another.	Complaint dismissed for want of prosecution. No orders as to costs.
100.	IEBC/DRC/CRGE/300/2022 Martin Munyua Waititu -Vs- The Returning Officer, Juja Constituency	Complainant to resubmit nomination papers within 48 hours from the date of issuance of the decision for consideration for registration by RO.
101.	IEBC/DRC/302/2022 Dickson Ouma Oselle v R.O, North Mugirango Constituency	The Complaint was dismissed with no orders as to costs and the decision of the Returning Officer was revoked.
102.	IEBC/DRC/CRGE/303/2022 Francis Kinyua & 2 Others -Vs- Purity Wangui Kuria Ngirichi & Kirinyaga County Returning Officer.	Complaint dismissed with no orders as to costs.
103.	IEBC/DRC/305/2022 Shukin Oonge Mongare v Eric Omanwa Basweti	Complaint was dismissed with no orders as to costs and the decision of the Returning Officer upheld.
104.	IEBC/DRC/307/2022 Charles Okelo Mkalo v Orange Democratic Movement Party & 2 Others	Complaint was dismissed with no orders as to costs and the decision of the Returning Officer upheld.
105.	IEBC/DRC/316/2022 Winnie Naliaka Wanyama -Vs- Returning Officer- Embakasi East Constituency	Complaint dismissed. The decision of the Respondent rejecting the nomination of the Complainant to contest for the position of Member of County Assembly, Mihang'o Ward, Nairobi County upheld. No costs awarded.
106.	IEBC/DRC/CRGE/319/2022 Hussein Kusow -Vs- The Returning Officer, Mandera County & 3 Others.	Complaint dismissed with no orders as to costs.
107.	IEBC/DRC/323/2022 Anthony Mkala Chitavi v Mombasa County Returning Officer & Another Interested Party - United Democratic Party (UDP)	Complaint was dismissed for lack of merit with no orders as to costs and the decision of the Returning Officer upheld.
108.	IEBC/DRC/06/2022 Francis M. Mwangi v R.O Embakasi North Constituency Filed by aspirant	Decline to resubmit his nomination papers despite appearing on time. Complaint allowed.
109.	IEBC/DRC/30/2022 Stephen Omodia Emusukut v RO Embakasi North Constituency. Filed by aspirant	Dismissed for non-compliance with the statutory requirements.
110.	IEBC/DRC/45/2022 Jeremiah Gitonga Luruti v R.O Igembe Central Constituency Filed by aspirant	Failure to meet required number of signatures. Dismissed

No.	COMPLAINT	DECISION DELIVERED
111.	IEBC/DRC/52/2022 Jonathan Murangiri v R.O Meru County Filed by aspirant	Did not meet required no of supporters for senate-dismissed.
112.	IEBC/DRC/60/2022 Ndirangu Mwaura v R.O Nairobi County Filed by aspirant	Issue on the RO's inability to load list of supporters on the Candidate Registration Management System. Allowed to appear before RO 48 Hrs.
113.	IEBC/DRC/84/2022 Allan Kipkoech Korir vs R.O Konoin Constituency	Non-compliant and lateness. dismissed.
114.	IEBC/DRC/89/2022 James Mwangi Gichohi v R.O Embakasi North Constituency & Jane M. Wangoi	Complaint against nominee, failure to resign from public office. Dismissed
115.	IEBC/DRC/103/2022 Abdi Salam Hassan Abdi v R.O Kajiado	Party member disputes-Dismitted no jurisdiction.
116.	IEBC/DRC/106/2022 Josphat Maruhi Kiama v CRO Makadara Constituency	Non-compliant. Dismissed
117.	IEBC/DRC/108/2022 Raymond Cheruyiot Rono v Kedowa Constituency	Lateness beyond gazette timelines. Dismissed.
118.	IEBC/DRC/110/2022 David Joel vs R.O Homabay County	Did not meet required supporters-dismissed.
119.	IEBC/DRC/113/2022 Bruno Ibhram Mwirigi Mburugu v Imenti North Constituency	Did not meet required no of supporters for MNA-dismissed.
120.	IEBC/DRC/126/2022 James Wahome-Ol-Kalau Constituency	Dismissed for want of prosecution.
121.	IEBC/DRC/130/2022 Paul Karugo Thang`wa Wanjiru v C.R.O Kiambu County	Dismissed Lateness and disqualification
122.	IEBC/DRC/143/2022 Anthony Kimani Nyororo v R.O Lari, Constituency	Insufficient number of supporters for MCA-Dismitted.
123.	IEBC/DRC/158/2022 John Kipchichir Boiywo v Baringo County	Dismissed-lateness.
124.	IEBC/DRC/170/2022 Victor Onyango vs R.O Kibra Constituency	Insufficient no of supporters for MCA-dismissed.
125.	IEBC/DRC/186/2022 Mark Obar Asuelaa v C.R.O Homabay County	Non-compliant and lateness on rescheduling.
126.	IEBC/DRC/188/2022 Benson Karisa Katsuki v. R.O Kibarani Constituency	Complainant`s name not in CRMS, complaint allowed, to resubmit papers.
127.	IEBC/DRC/192/2022 Phineas Mutharimi Michibu v C.R.O Igembe County	Non-compliant and lateness-Dismitted-
128.	IEBC/DRC/199/2022 Joseph Wambugu Kiragu v R.O Weslands Constituency	Dismissed-jurisdiction. Political parties.
129.	IEBC/DRC/217/2022 Evans Kaita vs R.O	Allowed to resubmit ID

No.	COMPLAINT	DECISION DELIVERED
	Nairobi County	
130.	IEBC/DRC/224/2022 Geoffrey Otieno Opiyo v R.O Kasipul Kabondo Constituency	Dismissed non compliance
131.	IEBC/DRC/233/2022 Moses Timothy Oguta vs R.O Busia County	Dismissed non compliance
132.	IEBC/DRC/237/2022 Gitonga Suvani v R.O Tharaka Constituency	Dismissed lateness
133.	IEBC/DRC/245/2022 Jeremiah Ekamaus Lomonkai v C.R.O Turkana County	Complaint against nominee. Education Qualification. Dismissed –committee bound by court order to stay revocation of degree certificate.
134.	IEBC/DRC/247/2022 Elizabeth Nzilani vs R.O Nairobi County	Dismissed for want of prosecution.
135.	IEBC/DRC/253/2022 Samuel Kiprotich Towett, R.O Kilgoris Constituency v R.O	Lateness beyond gazette timelines.
136.	IEBC/DRC/258/2022 Harrison Sang'alo Orono v R.O Teso North Constituency	Did not meet required number of supporters- dismissed.
137.	IEBC/DRC/272/2022 Kamau Manyara, R.O Molo Constituency	Dismissed for want of prosecution.
138.	IEBC/DRC/301/2022 David Kubasu Shimenga v R.O Ikolomani Constituency	Party primaries disputes-no jurisdiction.
139.	IEBC/DRC/306/2022 Felix Asiligwa Ongadi v R.O Kakamega County	Complaint against nominee. Dismissed –no jurisdiction to interrogate degree
140.	DRC 201/2022 Christopher Odhiambo Kobimo Versus R.O, Alego Usonga Constituency Filed by aspirant	Grounds: ❖ Insufficient supporters ❖ No Proposer nor Secunder. Outcome: ❖ Dismissed upon hg with no orders as to costs.
141.	DRC 67/2022 Wilson Kipngetch Kogo Versus R.O, Chesumei Constituency Filed aspirant	Grounds: ❖ Lateness Outcome: ❖ Dismissed upon hg with no orders as to costs.
142.	DRC 68/2022 Peter Ndungu Wachira Versus R.O, Embakasi North Constituency & Ouma Jedidah Ombwayo Filed by Voter	Grounds: ❖ Failure to resign as a public officer Outcome: ❖ Dismissed upon hg with no orders as to costs.
143.	DRC 22/2022 George Matala Wafula	Grounds: ❖ Insufficient supporters

No.	COMPLAINT	DECISION DELIVERED
	Versus R.O, Webuye West Constituency File by aspirant	Outcome: ❖ Dismissed upon hg with no orders as to costs
144.	DRC 111/2022 Francis Kipruto Bett & Francis Kibiwott Too Versus R.O, Chesumei Constituency Filed by Voters	Grounds: ❖ Party hopping Outcome: ❖ Dismissed upon hg with no orders as to costs
145.	DRC 48/2022 Samuel Kiiru Kaburia Versus Kieni East Constituency Filed by aspirant	Grounds: ❖ Failure to fill statutory Forms 11N & 11P Outcome: ❖ Dismissed upon hg with no orders as to costs
146.	DRC 85/2022 Irene Nyambura Wanyoike Versus CRO Kiambu County Filed by aspirant	Grounds: ❖ Lateness Outcome: ❖ Dismissed upon hg with no orders as to costs
147.	DRC 10/2022 Duncan Njenga Ng'ang'a Versus R.O, Kabete Constituency Filed by aspirant	Grounds: ❖ Lateness ❖ Lack of hard copy of symbol ❖ Lack of soft and hard copy of campaign schedule Outcome: Dismissed upon hg with no orders as to costs
148.	DRC 315/2022 Zacharia Anyangu Kwanzu Versus R.O, Emuhaya Constituency Filed by aspirant	Grounds: ❖ Lateness Outcome: ❖ Dismissed upon hg with no orders as to costs
149.	DRC 114/2022 Edward Inginda Akaranga Versus R.O, Kibera Constituency Filed by aspirant	Grounds: ❖ Lateness ❖ No proposer, nor seconder ❖ IDs not serialized ❖ Unfilled Form 19 Outcome: Dismissed upon hg with no orders as to costs
150.	DRC 80/2022 Albina Wambui Njoka Versus R.O, Mwea Constituency	Grounds: ❖ Not gazetted despite complying with all requirements

No.	COMPLAINT	DECISION DELIVERED
	Filed by aspirant	Outcome: ❖ Allowed. ❖ Complainant ordered to present herself before the RO within 48 hrs. ❖ RO ordered to register the complainant.
151.	DRC 23/2022 Kirui Vincent Versus Sotik Constituency Filed by aspirant	Grounds: ❖ No seconder ❖ Self-Declaration form not duly filled. ❖ Lateness Outcome: ❖ Dismissed upon hg with no orders as to costs
152.	DRC 86/2022 Jimi Richard Wanjigi Versus Wafula Chebukati & Daystar University Filed by aspirant	Grounds: ❖ Lack of degree Outcome: ❖ Dismissed upon hg with no orders as to costs
153.	DRC 299/2022 Hassan Mohamed Nur Versus Abdirahman Omar Adan & 4 others Filed by a voter	Grounds: ❖ Party primaries Outcome: ❖ Dismissed upon hg with no orders as to costs
154.	DRC 61/2022 John Muchiri Wanjiru Versus R.O, Mwea Constituency Filed by aspirant	Grounds: ❖ Not gazetted for failure to submit requisite forms after filling them out Outcome: ❖ Dismissed upon hg with no orders as to costs
155.	DRC 50/2022 George Jalang'o Midiwo Versus R.O, Gem Constituency Filed by aspirant	Grounds: ❖ Party hopping Outcome: ❖ Dismissed upon hg with no orders as to costs
156.	DRC 99/2022 Thomas Waitthaka Mumu Versus Dr. Irungu Kang'ata & 2 Others Filed by a voter	Grounds: ❖ Replacement of a running mate ❖ Failure to resign from public service. Outcome: ❖ Dismissed upon hg with no orders as to costs
157.	DRC 56/2022	Grounds:

No.	COMPLAINT	DECISION DELIVERED
	Gideon Ngewa Kenya & Another Versus Hon. Wavinya Ndeti Filed by voters	❖ Authenticity of degree. Outcome: ❖ Dismissed upon hg with no orders as to costs
158.	DRC 320/2022 Moses Nduiga Kamande Versus R.O, Maragwa Constituency Filed by a voter	Grounds: ❖ Failure to resign from public service Outcome: ❖ Dismissed upon hg with no orders as to costs
159.	DRC 280/20200 Simon Kokoyo Sirako Versus Jedidah Ouma Ombwayo Filed by a voter	Grounds: ❖ Failure to resign from public service Outcome: ❖ Summary dismissal due to similar file having been heard and determined (DRC No.68/2022)
160.	IEBC/DRC/32/2022 Florence Jelagat Kemboi v. CRO Baringo County Filed by aspirant	Dismissed for want of prosecution. Complainant failed to appear before the Dispute Resolution Committee.
161.	IEBC/DRC/33/2022 Samwel Otieno Otieno v. RO Rongo Constituency Filed by aspirant	Dismissed upon hearing. Complainant did not have the requisite number of signatures of supporters.
162.	IEBC/DRC/38/2022 Andrew Ndiritu Chiera v. RO Starehe Constituency Filed by aspirant	Dismissed upon hearing. DRC has no jurisdiction. Dispute is between the Complainant and UDA party and relates to political party nominations.
163.	IEBC/DRC/41/2022 Glory Mwendwa Kinoti v. RO Meru County. Filed by aspirant	Dismissed upon hearing. Complainant did not have the requisite number of signatures of supporters.
164.	IEBC/DRC/53/2022 Dickson Nyaribo v. RO Embakasi East Constituency. Filed by aspirant	Dismissed for want of prosecution Complainant failed to appear before the Dispute Resolution Committee.
165.	IEBC/DRC/54/2022 Mercy Chepkirui v. Returning Officer Narok	Dismissed upon hearing.

No.	COMPLAINT	DECISION DELIVERED
	West Constituency. Filed by aspirant	EACC self-declaration form was neither signed nor stamped Complainant, failed to observe the set timelines. Complainant did not have the requisite number of signatures of supporters.
166.	IEBC/DRC/66/2022 Hillary Mutuma Mugambi v. RO North Imenti Constituency Filed by aspirant	Dismissed upon hearing. The complainant was not gazetted to run as an independent candidate. Complainant never notified IEBC to allow Gazettement.
167.	IEBC/DRC/76/2022 Musa Barongo Newton v. Returning Officer Nyaribari Chache Constituency. Filed by aspirant	Dismissed upon hearing. Complainant did not have the requisite number of signatures of supporters.
168.	IEBC/DRC/83/2022 Ambassador Julius Kiema Kilonzo v. Dr. Julius Makau Malombe & Another Filed by aspirant	Dismissed upon hearing. DRC has no jurisdiction. Dispute is between the Complainant, Respondent, and Wiper party and relates to political party nominations
169.	IEBC/DRC/90/2022 Mary Muthoni Wachira v. RO Tetu Constituency Filed by aspirant	Dismissed upon hearing. Complainant is not a registered voter hence not allowed to stand for election. Time for voter registration elapsed.
170.	IEBC/DRC/91/2022 Roney Mutethia v. RO Igembe Central Constituency Filed by aspirant	Dismissed upon hearing. Complainant failed to present his self-declaration form within the stipulated time.
171.	IEBC/DRC/92/2022 Fredrick Gakuru Muchoki v. CRO Nyeri Country Filed by aspirant	Dismissed upon hearing. Complainant's USIU degree not authenticated by Commission for University Education
172.	IEBC/DRC/118/2022 Wilson Alinyo Mboiya v. RO Embakasi East Constituency	Dismissed upon hearing. Complainant, failed to observe the set timelines.

No.	COMPLAINT	DECISION DELIVERED
	Filed by aspirant	
173.	IEBC/DRC/141/2022 Stephen Otieno Odit v. RO Embakasi Central Constituency Filed by aspirant	Dismissed upon hearing. Complainant did not have the requisite number of signatures of supporters.
174.	IEBC/DRC/151/2022 Sheikh Sadiq Lukanu v. RO Kibra Constituency Filed by aspirant	Dismissed upon hearing. Complainant, failed to observe the set timelines.
175.	IEBC/DRC/152/2022 Siyad Abdi Gabo v. RO Kamukunji Constituency. Filed by aspirant	Dismissed for want of prosecution Complainant failed to appear before the Dispute Resolution Committee.
176.	IEBC/DRC/154/2022 Kathurima Naftaly v. CRO Meru County. Filed by aspirant	Dismissed upon hearing. No banker's cheque. Insufficient number of supporters.
177.	IEBC/DRC/156 / Winnie Naliaka Wanyama v. RO Embakasi East Constituency. Filed by aspirant	Dismissed for want of prosecution Complainant failed to appear before the Dispute Resolution Committee.
178.	IEBC/DRC/162/2022 Momanyi Bitange Kepha v. RO Mwatate Constituency Filed by aspirant	Dismissed upon hearing. No resignation letter.
179.	IEBC/DRC/174/2022 Charles Maina Muchai v. RO Starehe Constituency Filed by aspirant	Dismissed upon hearing. Complainant, failed to observe the set timelines.
180.	IEBC/DRC/185/2022 Isaac Aluoch Polo Aluochier v. Shadrack Otieno Nyawade & 14 Others. Filed by aspirant	Dismissed upon hearing. DRC lacks jurisdiction Matter is subjudice Matter raises issues to constitutional interpretation

No.	COMPLAINT	DECISION DELIVERED
		Complaint raises criminal issues
181.	IEBC/DRC/213/2022 Anthony Karanja Ndungu v. Returning Officer Nyeri Town Constituency. Filed by aspirant	Dismissed upon hearing. Complainant failed to prove that the RO registered candidates outside the stipulated timeline thereby violating the provisions of Gazette Notice No. 431, carried in Vol. CXXIV No. 14
182.	IEBC/DRC/219/2022 Carlton Muriithi Mnthama v. Returning Officer Runyenjes Constituency. Filed by aspirant	Allowed, complainant directed to appear before RO within 48 hours. Complainant demonstrated that failure to present original ID was occasioned by circumstances beyond his control.
183.	IEBC/DRC/225/2022 Walter Nyakundi Chweya v. Returning Officer Embakasi Central Constituency. Filed by aspirant	Dismissed upon hearing. Complainant not cleared to run as independent candidate. Never attended pre-nomination meeting.
184.	IEBC/DRC/228/2022 Zachary Aseda Omondi Rombo v. Returning Officer Kasipul Constituency. Filed by aspirant	Dismissed upon hearing. DRC has no jurisdiction Dispute is between the Complainant, Respondent, and ODM party and relates to political party nominations
185.	IEBC/DRC/230/2022 Dennis Gakuo Wahome v. Sakaja Koskei Johnson & RO Nairobi City County Filed by voter	Dismissed upon hearing. DRC has no jurisdiction to establish validity of degree certificates.
186.	IEBC/DRC/233/2022 Moses Timothy Oguta Wanyama v. CRO Busia County. Filed by aspirant	Dismissed for want of prosecution. Complainant failed to appear before the Dispute Resolution Committee.
187.	IEBC/DRC/251/2022 Joseph Omondi Agoko v. Returning Officer Ugunja Constituency. Filed by aspirant	Dismissed upon hearing. Complainant not gazetted to run as an independent candidate.
188.	IEBC/DRC/252/2022 Bernard Peter Odero v. Returning Officer Ugunja Constituency. Filed by aspirant	Dismissed upon hearing. Complainant not gazetted to run as an independent candidate.
189.	IEBC/DRC/259/2022	

No.	COMPLAINT	DECISION DELIVERED
	Musa Abdi Fafi v. Mohamud Subey Gedi & RO Fafi constituency. Filed by aspirant	Dismissed for want of prosecution Complainant filed an affidavit disowning the complaint.
190.	IEBC/DRC/276/2022 Ramadhan Mario Mbugua v. Returning Officer Naivasha Constituency. Filed by aspirant	Dismissed upon hearing. Insufficient number of signatures of supporters. Failure to comply with set timelines.
191.	IEBC/DRC/284/2022 Rotich Nicholas v. Returning Officer Kuresoi South Constituency. Filed by aspirant	Dismissed upon hearing. Insufficient number of signatures of supporters.
192.	IEBC/DRC/295/2022 Okello Dennis Kevin v. Returning Officer Namable Constituency. Filed by aspirant	Dismissed upon hearing. No banker's cheque presented.
193.	IEBC/DRC/297/2022 Nathaniel Kahihu Gaitho v. Returning Officer Gilgil Constituency. Filed by aspirant	Dismissed upon hearing. Insufficient number of signatures of supporters.
194.	IEBC/DRC/298/2022 Harold Makanza Kaulu v. Returning Officer Rabai Constituency. Filed by aspirant	Dismissed upon hearing. Failure to resign from public office.
195.	IEBC/DRC/148/2022 Dishon Aswani Luchera V R.O Kibra Constituency Dispute lodged by contestant.	Complaint dismissed due to lack of merit. Grounds for dismissal: a. Lack of proposer and seconder b. Lack of banker's cheque. c. copies of ID's not presented in a flash disk and not serialized.
196.	IEBC/DRC/78/2022 Mercy Mugure Karanja V R.O Kieni Dispute lodged by contestant.	Complaint dismissed on lack of merit. Grounds for dismissal: Application for registration was time-barred.
197.	IEBC/DRC/231/2022 Fredrick Owino Obenge v R.O Kibra Constituency.	Complaint dismissed on lack of merit. Grounds for dismissal: a. Application for registration was time-barred.

No.	COMPLAINT	DECISION DELIVERED
	Dispute lodged by contestant.	b. Lack of proposer and seconder. c. Anomalies between soft copy excel sheet and hard copies.
198.	IEBC/DRC/116/2022 Geng'a Elias Bitu v R.O Ruaraka Dispute lodged by contestant.	Complaint dismissed on lack of merit. Grounds for dismissal: a. Application for registration was time-barred.
199.	IEBC/DRC/09/2022 Manases Murithi v R.O Mwea Constituency Dispute lodged by contestant.	Complaint dismissed on lack of merit. Grounds for dismissal: a. Lack of EACC stamp. b. Application for registration was time-barred.
200.	IEBC/DRC/75/2022 Kipng'eno Mutai v. R.O Sotik Constituency Dispute lodged by contestant.	Complaint dismissed on lack of merit. Grounds for dismissal: a. Lack of proposer and seconder with capacity.
201.	IEBC/DRC/150/2022 Jerad Amos Kabugi v C.R.O Murang'a Dispute lodged by contestant.	Complaint dismissed on lack of merit. Grounds for dismissal: The Complainant's running mate for position of deputy governor did not meet the deadline for submission of names of independent candidates.
202.	IEBC/DRC/16/2022 David Mamali Wanjala v R.O Bumula Constituency Dispute lodged by contestant.	Complaint dismissed on lack of merit. Grounds for dismissal: The name on the Complainant's nomination certificate did not match the name on his National Identification Card. Did not correct this anomaly in good time.
203.	IEBC/DRC/20/2022 Steve Kipruto v C.R.O Baringo County. Dispute lodged by contestant.	Complaint dismissed on lack of merit. Grounds for dismissal: Lack of sufficient supporters.

No.	COMPLAINT	DECISION DELIVERED
204.	IEBC/DRC/189/2022 Titus Waithaka Wanjiru v R.O Othaya Constituency Dispute lodged by contestant.	Complaint dismissed on lack of merit. Grounds for dismissal: a. Lack of sufficient supporters. b. Lack of EACC stamp. c. Application was time-barred. d. Lack of banker's cheque.
205.	IEBC/DRC/122/2022 Kimemia Juliet Muthoni v C.R.O Kiambu County Dispute lodged by contestant.	Complaint dismissed on lack of merit. Grounds for dismissal: a. The running mate's degree certificate had not been authenticated by the Commission for University Education. b. Application for registration was time-barred.
206.	IEBC/DRC/86/2022 Jimi Richard Wanjigi v Wafula Chebukati & Daystar University Dispute lodged by contestant.	Complaint dismissed on lack of merit. Grounds for dismissal: a. Lack of sufficient supporters. b. Lack of degree certificate. c. failure to present the nomination certificate of the deputy governor nominee within prescribed timelines.
207.	IEBC/DRC/117/2022 Basilio Mutuma v R.O Kajiado North Constituency Dispute lodged by contestant.	Complaint dismissed on lack of merit. Grounds for dismissal: Lack of sufficient supporters.
208.	IEBC/DRC/27/2022 Herbert Nyaruri v R.O Nyaribari Masaba Constituency Dispute lodged by contestant.	Complaint dismissed on lack of merit. Grounds for dismissal: The proposer and seconder had not signed the Form 15.
209.	IEBC/DRC/101/2022 Kairu Peter Chege v UDA 7 Others Dispute lodged by contestant.	Complaint and Application for re-instatement dismissed on lack of jurisdiction. Grounds for dismissal: Lack of jurisdiction as it was a dispute between a member of a political party and the political party.

No.	COMPLAINT	DECISION DELIVERED
210.	IEBC/DRC/03/2022 Ojijo Ogillo Mark Pascal & 2 others v IEBC Dispute lodged by contestant.	Complaints withdrawn by the Complainants in consensus.
211.	IEBC/DRC/04/2022 Ojijo Ogillo Mark Pascal v IEBC Dispute lodged by contestant.	Complaint dismissed on lack of merit. Grounds for dismissal: Independent presidential aspirant did not submit his supporters' details by 25 th May, 2022.
212.	IEBC/DRC/226/2022 Timothy Ayieko Ogingo v CRO Nairobi County Dispute lodged by contestant.	Complaint dismissed on lack of merit. Grounds for dismissal: a. Lack of proposer and seconder. b. Lack of running mate's details.
213.	IEBC/DRC/149/2022 Martin Kipkoech v R.O Kwanza Constituency Dispute lodged by contestant.	Complaint dismissed on lack of merit. Grounds for dismissal: Application for registration was time-barred.
214.	IEBC/DRC/05/2022 Mogendi Wilson Saiya v R.O Kuria West Constituency Dispute lodged by contestant.	Complaint dismissed on lack of jurisdiction. Grounds for dismissal: Dispute between a member of a political party and the political party.
215.	IEBC/DRC/257/2022 Stephen Njoroge Mungai v R.O Kajiado North Constituency Dispute lodged by contestant.	Complaint dismissed on lack of merit. Grounds for dismissal: a. Lack of sufficient supporters. b. Lack of proposer and seconder.
216.	IEBC/DRC/57/2022 Nicholas Kiplangat Mutai v R.O Narok West Constituency Dispute lodged by contestant.	Complaint dismissed on lack of merit. Grounds for dismissal: Application for registration was time-barred.
217.	IEBC/DRC/210/2022 Salydiah Wangui Mwahu v R.O. Maragwa Constituency Dispute lodged by contestant.	Complaint dismissed on lack of merit. Grounds for dismissal: a. The name on her national identification card, did

No.	COMPLAINT	DECISION DELIVERED
		not match the name on her nomination certificate and her self-declaration form. b. Lack of seconder.
218.	IEBC/DRC/296/2022 Nowa Magero v R. O. Ruaraka Constituency Dispute lodged by contestant.	Complaint dismissed on lack of merit. Grounds for dismissal: a. Lack of sufficient supporters. b. Lack of proposer with capacity. c. Lack of duly filled forms.
219.	IEBC/DRC/320/2022 Moses Nduiga Kamande v Hillary Muigai Muchoki Dispute lodged by voter.	Complaint summarily dismissed for failure to disclose a reasonable cause of action.
220.	IEBC/DRC/37/2022 Maur Abdalla Bwanamaka Matapu v Chama Cha Uzalendo Dispute lodged by contestant.	Complaint withdrawn.
221.	IEBC/DRC/74/2022 Daniel Mola Watako v R.O Matungu Constituency. Dispute lodged by contestant.	Complaint dismissed for want of prosecution.
222.	IEBC/DRC/309/2022 Peter Wambuthsi Masakhwe v R.O Mumias West Dispute lodged by contestant.	Complaint dismissed for want of prosecution.
223.	IEBC/DRC/314/2022 Justus Muketi v R.O. Matungu Constituency Dispute lodged by contestant.	Complaint dismissed for want of prosecution.
224.	IEBC/DRC/321/2022 Mohammed Salat Abdille v R.O. Bura Constituency Dispute lodged by contestant.	Complaint dismissed for want of prosecution.
225.	IEBC/DRC/287/2022 John Otieno Opiyo v R.O. Migori County Dispute lodged by contestant.	Complaint dismissed for want of prosecution.
226.	IEBC/DRC/216/2022 Benard Mugo v C.R.O Nairobi County Dispute lodged by voter.	Complaint dismissed for want of prosecution.
227.	IEBC/DRC/288/2022 Victor Munyao Gido v R.O. Kajiado North Constituency Dispute lodged by contestant.	Complaint dismissed for want of prosecution.
228.	IEBC/DRC/304/2022 Brian Kipkirui Keter Vs R.O Kericho County	Complaint Dismissed.
229.	IEBC/DRC/256/2022 Tarus Kipngetch Adams Vs R.O Sigowet/Soin Constituency	Complaint dismissed.

No.	COMPLAINT	DECISION DELIVERED
230.	IEBC/DRC/221/2022 Walter Onchonga Mongare Vs Chairman IEBC	Complaint dismissed.
231.	IEBC/DRC/277/2022 Serah Kiwasi Kiwinda Vs R.O Wundanyi Constituency	Complaint dismissed.
232.	IEBC/DRC/70/2022 Michael Adie Kiage Vs R.O Kabondo Kasipul Constituency and Peter Odhiambo Agoro	Complaint allowed with directions that the Returning Officer do consider the nomination document to afresh considering the new evidence.
233.	IEBC/DRC/81/2022 David Renger Tingwet Vs R.O Mt. Elgon Constituency	Complaint dismissed.
234.	IEBC/DRC/81/2022 Nick Onyango Anyonga Vs R.O Ruaraka Constituency	Complaint Dismissed
235.	IEBC/DRC/214/2022 Kenneth Gitonga Njeru Vs R.O Ruiru Constituency	Complaint dismissed.
236.	IEBC/DRC/81/2022 Samuel Kinaro Mokuu Vs R.O Ruiru Constituency	Complaint dismissed.
237.	IEBC/DRC/129/2022 Dr. Ekuru Aukot & another Vs Wafula Chebukati	Complaint dismissed.
238.	IEBC/DRC/222/2022 Agnes Nailantei Shonko Wachiora Vs R.O Kasarani Constituency	Complaint dismissed.
239.	IEBC/DRC/277/2022 Peter Kilonzo Muasya Vs R.O Embakassi South Constituency	Complaint dismissed.
240.	IEBC/DRC/19/2022 James Wanjohi Njoroge Vs R.O Roysambu Constituency	Complaint dismissed.
241.	IEBC/DRC/133/2022 Joseph Kamau Njeri Vs RO Thika Constituency	Complaint allowed. Complainant to deliver documents to Returning Officer within 3 days otherwise the orders lapse.
242.	IEBC/DRC/15/2022 Bernard Makau Vs R.O Nairobi County	Complaint allowed. Complainant to submit compliant list to the Returning Officer within 3 days failure to which the orders lapse.
243.	IEBC/DRC/271/2022 Benson Mwai Kuyu Vs R.O Roysambu Constituency	Complaint dismissed.
244.	IEBC/DRC/142/2022 David Noti Kombe Vs R.O Kilifi County	Complaint allowed. Complainant to present hios documents to the Returning Officer within 48 hours of service.
245.	IEBC/DRC/159/2022 Gideon Kuria Munyori Vs R.O Lari Constituency	Complaint dismissed.
246.	IEBC/DRC/69/2022 Jacob Gekonge Kwaba Vs R.O Nyaribari	Complaint dismissed.

No.	COMPLAINT	DECISION DELIVERED
	Chache Constituency	
247.	IEBC/DRC/235/2022 Charles Nyamwange V Vs R.O Kisii County	Complaint dismissed.
248.	IEBC/DRC/82/2022 Dr. Ekuru Aukot Vs Raila Odinga	Complaint dismissed.
249.	No. 120 Of 2022 Bernard Omare Fidelis Vs R.O Embakasi South Const.	Complaint dismissed
250.	No. 163 Of 2022 Harrison Maina Bonne Vs Returning Officer-Kasarani Consti.	Complaint allowed
251.	No. 163 Of 2022 Joseph Mwaura Kariithi Vs Returning Officer-Kasarani Const.	Complaint dismissed.
252.	No. 160 Of 2022 Peter Kiarri Muchina Vs Returning Officer-Roysambu Const	Complaint dismissed.
253.	No. 171/2022 Stephen Ndungu Mathu Vs Returning Officer, Kiambaa Consti	Complaint dismissed.
254.	No.100/2022 Abraham Kemei Vs Returning Officer-Uasin Gishu County	Complaint dismissed.
255.	No.21/2022 Amos Ngata Kamau Vs Returning Officer-Kasarani Const	Complaint dismissed.
256.	No.34/2022 Edward Kipchumba Vs Returning Officer-Uasin Gishu County	Complaint dismissed.
257.	No.47/2022 Isaac Kimutai Cheruyot Vs Returning Officer-Kipkelion East Const	Complaint dismissed.
258.	No.194/2022 Kevin Amoko Vs Returning Officer-Embakasi West	Complaint dismissed.
259.	No.71/2022 Laban Basil Lewela Vs Returning Officer-Juja Const.	Complaint dismissed.

No.	COMPLAINT	DECISION DELIVERED
260.	No.94/2022 Geoffrey Sagwe Nyaberi. Vs County Returning Officer-Nyamira County	Complaint dismissed.
261.	No.191/2022 Mathaiya Charles Ndong Vs Returning Officer-Lari Consti	Complaint dismissed.
262.	No.193/2022 John Mugu Nyambura Vs Returning Officer-Lari Consti	Complaint dismissed.
263.	No.220/2022 Bernice Huria Vs Returning Officer-Makadara Constituency	Complaint dismissed.
264.	No.244/2022 Moses Wachira Ikamba Vs Returning Officer-Mbeere South	Complaint dismissed.
265.	No.289/2022 Fred Wangwe Khaemba Vs Returning Officer-Dagoretti South Constituency	Complaint dismissed.
266.	No.294/2022 Charles Bambo Bilal Vs Returning Officer-Msambweni Constituency.	Complaint dismissed.
267.	No.95/2022 Millicent Wakio Vs Returning Officer- Taveta Constituency	Complaint allowed
268.	No.24/2022 Ahmed Hussein Maalim Mohammed Vs Returning Officer Mandera South Const.	Complaint dismissed for non-attendance & want of prosecution
269.	David Kiprono Sudi Vs Returning Officer Elgeyo Marakwet & Timothy Kipchumba Toroitich	Complaint withdrawn
270.	No.138/2022 Simon Meja Nzioka Vs R.O Embakasi West	Complaint dismissed for non-appearance and want of prosecution
271.	No.223/2022 Vincent Mariita Omaso Vs	Complaint Withdrawn by consent

No.	COMPLAINT	DECISION DELIVERED
	R.O Nyamira County	
272.	IEBC/DRC/12/2022 Josephine Njeri Chege Vs C.R.O Nyandarua County	Complainant dismissed..
273.	IEBC/DRC/179/2022 Josephine Mukami Kariuki Vs R.O Kikuyu Constituency	Complaint dismissed.
274.	IEBC/DRC/039/2022 Gladys Wanjiku Vs CRO Nyandarua County	Complaint dismissed.
275.	IEBC/DRC/205/2022 Dan Odhiambo Kodhe Vs R.O Embakasi West Constituency	Complaint dismissed.
276.	IEBC/DRC/28/2022 Dorcas Jeruto Chepkwonya Vs R.O Marakwet East Constituency	Complaint allowed with directions to appear before the Returning Officer within 48 hours
277.	IEBC/DRC/31/2022 Kiplimo Kiprop Michael Vs R.O Marakwet East Constituency	Complaint dismissed.
278.	IEBC/DRC/79/2022 Zacharia Mogaka Openda Vs R.O North Mugirango Constituency	Complaint dismissed
279.	IEBC/DRC/168/2022 Lilian Sidi Vs R.O Kisauni Constituency Constituency	Complaint allowed with directions that the R.O and ICT Director of Voter Registration to regularize her voter status. Complainant directed to appear before the R.O within 48 .
280.	IEBC/DRC/123/2022 Johnson Oduk Vs R.O Langata Constituency & 2 Others	Complaint dismissed.
281.	IEBC/DRC/180/2022 David Mucangi Nyagah Vs C.R.O Embu County	Complaint dismissed.
282.	IEBC/DRC/187/2022 Geoffrey Namunyu Elwak Vs R.O Embakasi East Constituency	Complaint dismissed.
283.	IEBC/DRC/211/2022 Brian Kimeli Kosgey Vs R.O Embakasi East Constituency	Complaint dismissed.
284.	IEBC/DRC/190/2022 Joseph Mokua Manyara Vs Mwanicha Okioma & 4 Others	Complaint dismissed.

No.	COMPLAINT	DECISION DELIVERED
285.	IEBC/DRC/242/2022 Samuel Leshan Kuyo vs R.O Embakasi East Constituency	Complaint dismissed.
286.	IEBC/DRC/317/2022 Charles Ondieki Opiyo Vs R.O Dagoretti North Constituency	Complaint dismissed.
287.	IEBC/DRC/324/2022 David Njilithia Mberia Vs R.O Langata Constituency & 3 Others	Complaint dismissed.
288.	IEBC/DRC/264/2022 Gabriel Kimeli Biwott Vs C.R.O Elgeyo Marakwet County & 2 Others	Complaint withdrawn by the Complainant.
289.	IEBC/DRC/261/2022 Benson Wachira Wanyeki Vs Patrick Thuku Karemeri & R.O Kasarani Constituency	Complaint allowed with directions to the Returning Officer to vet the 2 nd Respondent afresh within 72 hours. Complainant to furnish the Returning Officer with evidence within 48 hours.
290.	IEBC/DRC/212/2022 Ekai Lomoru Nicholas Vs C.R.O Turkana County & 2 Others	Complaint dismissed.
291.	IEBC/DRC/264/2022 Ian Kiprof Orogon Vs CRO Elgeyo Marakwet County & 2 Others	Complaint withdrawn.
292.	IEBC/DRC/310/2022 Katha Paul Nzuki Vs R.O Msambweni Constituency	Complaint dismissed.
293.	IEBC/DRC/29/2022 Mary Muthoni Wachira Vs R.O. Tetu Constituency	Complaint dismissed for want of prosecution
294.	IEBC/DRC/196/2022 Muguiru Mwangi Vs R.O Starehe Constituency	Complaint dismissed for want of prosecution
295.	IEBC/DRC/184/2022 Salim Nthuku Mitabara Vs Abel Mwamburi & R.O Embakasi Wst Constituency	Complaint dismissed.
296.	IEBC/DRC/181/2022 Rianga Eric Vs R.O Kandara Constituency	Complaint dismissed for want of prosecution
297.	IEBC/DRC/166/2022 Januarious Kibet Vs R.O Mosop Constituency	Allowed. Complainant to appear before the RO within 48 hours.
298.	IEBC/DRC/207/2022 Felix Ndeti Vs R.O Nairobi County	Complaint dismissed.

No.	COMPLAINT	DECISION DELIVERED
299.	IEBC/DRC/035/2022 Dennis Mutuku Vs R.O Matungulu Constituency	Complaint dismissed.
300.	IEBC/DRC/198/2022 Baruch Kipchirchir Vs R.O Mosop Constituency	Complaint dismissed.
301.	IEBC/DRC/51/2022 Zachariah Momanyi Vs R.O Nairobi County	Complaint dismissed.
302.	IEBC/DRC/241/2022 Patrick Kinyua Vs R.O Starehe Constituency	Complaint dismissed.
303.	IEBC/DRC/07/2022 George Nguri Oljoroorok Vs R.O Oljoroorok Constituency	Allowed. Complainant to appear before the RO within 48 hours.
304.	IEBC/DRC/262/2022 Samson Opata Vs R.O Embakasi South Constituency	Complaint dismissed.
305.	IEBC/DRC/58/2022 Peter Abuga Vs R.O West Mugirango Constituency	Complaint dismissed.
306.	IEBC/DRC/77/2022 Loice Akoth Kawaka & another Vs Oscar Oluoch Abote & Others	Complaint dismissed.
307.	IEBC/DRC/164/2022 Beatrice Nyakambi Vs R.O Nyamira County	Complaint dismissed.
308.	IEBC/DRC/146/2022 Anderson Kinuthia Vs R.O Kabete Constituency	Complaint dismissed.
309.	IEBC/DRC/322/2022 Dancan Ochieng Vs R.O Embakasi West Constituency	Complaint dismissed.
310.	IEBC/DRC/02/2022 Nicholas Ouma & Others Vs ODM Party & Others	Complaint dismissed.
311.	IEBC/DRC/215/2022 Elijah Asikoya Vs R.O Westlands Constituency	Complaint dismissed.
312.	IEBC/DRC/311/2022 Kipkemoi Tito Vs R.O Emurua Dikirr Constituency	Complaint dismissed.

No.	COMPLAINT	DECISION DELIVERED
313.	IEBC/DRC/59/2022 Joseph Likoot Vs R.O Samburu County	Complaint dismissed.
314.	IEBC/DRC/308/2022 George Mwiti Vs R.O Kajiado North Constituency	Complaint dismissed.
315.	IEBC/DRC/153/2022 Alex Wanjala Vs R.O Dagoreti North Constituency	Complaint dismissed.
316.	IEBC/DRC/318/2022 Abdalah Kombo Vs R.O Likoni Constituency	Complaint dismissed.
317.	IEBC/DRC/197/2022 Joseph Kahira Vs R.O Thika Town Constituency	Complaint dismissed.
318.	IEBC/DRC/107/2022 Paul Bwire Vs Jubilee Party & Another	Complaint dismissed.
319.	IEBC/DRC/255/2022 Lucas Gicharu Muiruri Vs R.O Gatundu North	Complaint dismissed.
320.	IEBC/DRC/313/2022 Anthony Kitele Vs R.O Kangundo Constituency	Complaint dismissed.
321.	IEBC/DRC/140/2022 Moses Wa Muruka Vs R.O Kandara Constituency	Complaint dismissed.
322.	IEBC/DRC/264/2022 Ian Kiprop Orogoin Vs C.R.O Elgeyo Marakwet County & 2 Others	Complaint withdrawn by the Complainant.
323.	IEBC/DRC/CRGE/73/2022 Moses Ayieko Ntabo and Wesley Obwangi vs C.R.O Kisii County and Simba Arati	Complaint withdrawn by the Complainant.

Annex 4: Contractual Agreements For Procurement Of Goods And Services

S/NO.	TENDER NUMBER	CONTRACT	COMPANY	PERIOD
1.	IEBC/RFP/21/01/2021-2022	Request for proposal for media planning, buying and production services, public relations, strategic communication and media monitoring services firm for 3 years framework contract	Artful Eyes Production Limited	3 Years
2.	IEBC/OT/21/008/2021-2022	Contract for the provision of microsoft enterprise agreement license subscription and support services	Avuity Limited	3 Years
3.	IEBC/RFP/21/01/2021-2022	Request for proposal for media planning, buying and production services, public relations, strategic communications and media monitoring services, firms for 3 years' framework contract Lot 2: provision for public relations, strategic communications and media monitoring services	Apex Communications Limited	3 Years
4.	IEBC/OT/001/21/2021-2022	Contract for the supply, delivery, installation, testing, commissioning, support and maintenance of KIEMS and hardware equipment and accessories	M/S Smartmatic Int. Holding B.V	3 Years
5.	IEBC/OIT/002/21/2021-2022	Supply and delivery of ballot papers, register of voters: election result declaration forms to be used at the constituency, county and national tallying centre	Inform Lykus (Hellas) Sa	3 Years
6.	IEBC/OT/21/018/B/2021-2022	Contract for the supply and delivery of desktop, notebooks, smartphones, tablets and accessories	Dignity Traders Limited	3 Years
7.	AGREEMENT UNDER SECTION 4 (2) (1) OF THE PPADA	Acquisition of the National Tallying Centre	The Bomas Of Kenya	
8.	IEBC/OIT/001/21/2021-2022	Contract for the supply, delivery, installation, testing , commissioning, support and maintenance of kenya Intergrated Elections Management Systems (KIEMS) and hardwarre equipment and accessories	Smartmatic International Holding B. V	
9.	IEBC/OT/21/07/2021-2022	Contract for audit and ISO certification of the election technology	Serianu Limited	
10.	IEBC/OT/016/21/2021-2022	Contract for the supply, delivery, installation, testing and commissioning of an Information Technology Service Management (ITSM) solution	Conez Technologies Limited	2 Years
11.	IEBC/DP/22/001/2021-2022	Contract for the provision of KIEMS network for 2022 General Election lot 1	Airtel Networks Kenya Limited	3 Years
12.	IEBC/RFP/21/03/B/2021-2022	Contract for request for proposal for audit of the Register Of Voters	M/S Kpmg Adisory Services Limited	1 Year

S/NO.	TENDER NUMBER	CONTRACT	COMPANY	PERIOD
13.	IEBC/DP/22/001/2021-2022	Contract for the provision of KIEMS network for 2022 General Election	Safaricom Plc	3 Years
14.	IEBC/OT/21/033/2021-2022	Contract for the supply and delivery of assorted non strategic election materials Lot4-supply and delivery of assorted IEBC rubber stamps	Jugi Works Limited	3 Years
15.	IEBC/CN/22/001/2021-2022	Contract for the provision of KIEMS network for 2022 general election	Otsa Tech Limited	3 Years
16.	IEBC/OT/21/017/2021-2022	Contract for the provision of waste paper and records disposal services.	Kamango Waste Paper (Kenya) Ltd	3 Years
17.	IEBC/OT/21/013/2020-2021	Contract for the supply and delivery of information education and communication materials. Production of IEBC branded muslim scarfs.	Rilleys Supplies	3years
18.	SERVICE LEVEL AGREEMENT	Clearing and forwarding and transportation services of election and education materials	Postal Corporation Of Kenya	
19.	IEBC/OT/21/021/2021-2022	Contract for the supply and delivery and installation of network, monitoring tool, licences, software support and maintenance	Sasait Limited	26 th April 2022
20.	IEBC/OT/21/010/B/2021-2022 Framework Medium Duty Color Multi-Functional Printers	Contract for the supply and delivery of multi functional printers	Zolts Solution Limited	3 Years
21.	IEBC/OT/21/032/2021-2022	Supply and delivery of stand alone solar photovoltaic lamp	Pegasus Merchants Kenya Limited	3 Years
22.	IEBC/OT/22/025/2021-2022	Contract for the renovation of IEBC offices	Flexolink Limited	
23.	IEBC/OIT/002/21/2021-2022	Contract for the supply and delivery of Ballot Papers, Register of Voters, statutory election result, declaration forms to be used at the Polling Stations, election and referendum results declaration forms to be used at the Constituency, County and National Tallying Centre.	Inform Lykos (Helles)	3 Years

S/NO.	TENDER NUMBER	CONTRACT	COMPANY	PERIOD
24.	IEBC/OT/21/019/2021-2022	Contract for the supply, delivery, installation, testing and commissioning of hansard system, recorders, sound mixers, microphones and software.	Pillar Audio Visual Services Limited	2 Years
25.	IEBC/OT/21/010/B/2021-2022 framework@ 1. Heavy duty multifunctional printers 2. Medium duty color, multi-functional printer 3. Heavy duty black and white multi-functional printer	Contract for the supply and delivery of multifunctional printers	MFI Documents Solution	3 Years
26.	IEBC/OT/21/008/2021-2022	Contract for the provision of microsoft enterprise agreement lincense subscription and support service	Avuity Limited	3 Years
27.	IEBC/DP/22/002/2021/2022	Contract for the provision of candidate of Registration Management System(CRMS) support, maintainance and enhancement	M/S Brisk Solution Company	3 Years
28.	IEBC/OT/022/040/2021-2022	supply and delivery of 3kg gas cylinders	1. Swift Energies Limited 2. Decree Company Limited	3 Years
29.	IEBC/OT/21/031/2021-2022	Supply and delivery of election forms	Punchlines Limited	3 Years
30.	IEBC/OT/21/32/2021-2022.	Provision of printing services (Observer Guidelines)	EAPC Printing Solution	3 Years
31.	IEBC/OT/21/32/2021-2022.	Provision of printing services (certificate for voter educators)	Zallian Agencies Limited	3 Years
32.	IEBC/OT/21/031/2021-2022	Supply and delivery of drinking water	Righthill Limited	3 Years
33.	IEBC/OT/21/037/2021-2022	Provision of cleaning services	Liga Holdings Limited	3 Years
34.	IEBC/OT/21/020/B/2021-2022	Provision of office repairs and maintainance	Lizcon Agencies	3 Years

S/NO.	TENDER NUMBER	CONTRACT	COMPANY	PERIOD
35.	IEBC/OT/21/033/2021-2022	Supply and delivery of assorted non – strategic election materials Lot 2 – supply and delivery of IEBC branded greenish reflector jackets.	Solwise Business Solution Limited	3 Years
36.	IEBC/OT/022/28/2021-2022	Supply and delivery of personal protective equipments	Turji Trading Limited	3 Years
37.	IEBC/OT/022/28/2021-2022	Supply and delivery of personal protective equipments	Oceanworks Limited	3 Years
38.	IEBC/OT/022/28/2021-2022	Supply and delivery of Personal Protective Equipments	Winko Enterprises	3 Years
39.	IEBC/OT/21/033/2021-2022	Supply and delivery of non strategic materials, (hacksaw blades)	Northview Limited	3 Years
40.	IEBC/DP/02/2022/2023	Supply and delivery of kyocera toners	MFI Documents	
41.	IEBC/OT/21/033/2021-2022	Contract for the supply and delivery of assorted non – strategic election materials Lot 1 – supply of A4 tamperproof envelopes and A3 tamperproof envelopes	Hilverda Contactors	3 Years
42.	IEBC/OT/21/033/2021-2022	Contract for the supply and delivery of assorted non – strategic election materials Lot 2 – supply and delivery of IEBC branded greenish reflector jackets	Solwise Business Solutions Limited	3 Years
43.	IEBC/OT/21/033/2021-2022	Contract for the supply and delivery of assorted non – strategic election materials Lot 3 – supply of hacksaw blades	North View Limited	3 Years
44.	IEBC/OT/21/033/2021-2022	Contract for the supply and delivery of assorted non – strategic election materials Lot 4 – supply and delivery of assorted IEBC rubber stamps	Jugi Works Limited	3 Years
45.	IEBC/OT/21/039/2021/2022	Contract for provision of residential security services	Flashcom Security Limited	3 Years

Annex 5: Memorandum Of Understanding (Mous) And Partnership Agreements With Partners

No.	MOU	Reason
1.	MOU with The General Elections Commission Of The Republic of Indonesia	strengthen the existing friendly relations and bilateral cooperation between the Parties.
2.	MOU with Kenya Editors Guild.	To establish common ground on priority areas of cooperation, ahead of, during and after the 2022 elections with the objective to enhance the delivery of critical, reliable, credible, verifiable electoral information to the citizens of Kenya in a timely fashion through the news media while observing the tenets of independent journalism.
3.	MOU with the Kenya Institute Of Special Education	facilitate and enhance collaborative activities between IEBC and KISE. The collaboration will cover the broad area of inclusion of Persons with Disabilities in the electoral process.
4.	MOU with Twaweza East Africa	voter education and communication
5.	MOU with Law Society of Kenya	For the conduct of LSK Elections.
6.	Tripartite MOU between and among the Independent Electoral And Boundaries Commission (IEBC), The European Centre For Electoral Support (ECES), and The Political Parties Liaison Committee (PPLC)	maximizing on synergies to enhance the promotion of sustainable democracy and resolution of electoral disputes in the run up to the 2022 General Election.
7.	Partnership agreement with Octopizzo Foundation (O.F)	for Voter registration, education, and participation
8.	Media Council of Kenya (“MCK”)	develop a partnership that sets out the terms of engagement and responsibilities between parties towards a professional and Election observation and responsible media on election preparedness and training.
9.	National Community Based Organization Council (NCBOC)	For voter Education
10.	The National Council of NGOs	to facilitate and enhance collaboration in partnership activities, Voter Education, Election Observation, inclusion of Women, Youths and Persons with Disabilities in the electoral process.
11.	One Touch Marketing (OTM)	To educate the Kenyans citizens to participate in the

No.	MOU	Reason
		promotion of peace.
12.	Association of Grassroot Journalists Kenya	encouraging and promoting high standards of professionalism and the promotion of current, reliable reporting
13.	Meta Platforms, INC.,	Training by META's GPN team to The IEBC officials on best practices in the use of social media for election;
14.	Kenya Red Cross Society	For conducting of elections of the Kenya Red Cross Society.
15.	Scooper News (Transsion Holdings)	for election publication and IEBC general election brand awareness
16.	Office of the Director of Public Prosecutions	Information sharing between the parties to enhance a smooth and seamless process of prosecuting election offences.
17.	The Disability Mainstreaming Foundation of Kenya (DMF-K)	improve the perspective of persons with disabilities by reflecting on a better society for all through enforcing the constitution of Kenya (2010), UN-CRPD and the disability law, 2003.
18.	The Commission on Administrative Justice	promotion of fair administrative action, service delivery, access to information and constitutionalism.
19.	Ethics And Anti-Corruption Commission (EACC)	collaboration between IEBC and EACC, leveraging on their respective mandates, on enforcement of moral, ethical and integrity requirements for persons seeking election to state office, in a manner that will be mutually benefiting and reinforcing in the interest of both Parties
20.	The International Foundation For Electoral Systems (IFES)	facilitate and enhance collaborative activities between IEBC and IFES to monitor online hate speech pertaining to the 2022 Kenya General Election and electoral support.

Annex 6: Gazette Notices Description

S/NO	GAZETTE NOTICE (DESCRIPTION)	DATE OF PUBLICATION
1.	Notice of Presidential Election and attendant timelines	21/1/22
2.	Registration centers in Kenya, corrigenda, addendum, registration officers, centers etc.	21/1/22
3.	Notice for the elected persons in the 16/12/21 by- election.	22/12/21
4.	<ul style="list-style-type: none"> - Registration Centers - Registration & Assistant Registration Officers - Corrigenda & Addendum - Returning & Deputy Returning Officer 	06/10/21
5.	Nominated Members to County Assemblies of Laikipia, Kiambu and Samburu	24/8/21
6.	Contributions and spending limits for political parties	24/8/21
7.	Persons contesting in the party primaries for by-elections scheduled to be held on 14/10/21	12/8/21
8.	Corrigenda in returning officers by-election for 14/10/21	29/7/21
9.	By-election date for Eldas, Kiagu and Nguu/ Masumba wards & The returning officers for the said by- elections to be held on 14/10/21	28/7/21
10.	Persons participating in the party primaries for different political parties	9 th April, 2022
11.	Names and Symbols of Independent Candidates participating in the nomination and attendant corrigenda and addendum	May, 2022
12.	Appointment of Returning Officers and their deputies for purposes of the General Election and the attendant corrigenda and addendum.	May, 2022
13.	Notice Certifying that the Revision of the Register of Voters has been Completed for Purposes of the 9th August, 2022 General Election	June, 2022
14.	Appointment of Members of the Independent Electoral and Boundaries Commission Dispute Resolution Committee	12 th June, 2022
15.	Notice on Requirements for Submission of Party Lists	3 rd June, 2022
16.	Suspension of continuous voter registration availability of the Register of Voters for verification	2 nd May, 2022
17.	Availability of The Register of Voters for verification	2 nd May, 2022
18.	Appointment of Returning and Deputy Returning Officers for purposes of the By-Election of Member of Mahoo Ward in Taita Taveta County Assembly scheduled to be held on 16th December, 2021	14 th January, 2022
19.	Appointment of Registration Officers and Assistant Registration Officers	14 th January, 2022

S/NO	GAZETTE NOTICE (DESCRIPTION)	DATE OF PUBLICATION
20.	Declaration of Persons Elected as Members of County Assemblies for Kiagu and Mahoo Wards in Meru and Taita Taveta County Assemblies, respectively, during the By-elections held on 16th December, 2021	4 th January 2022
21.	Certifying the Completion of Revision of the Register of Voters for Member of Mahoo County Assembly Ward in Taita Taveta County Assembly Scheduled to be Held on 16th December, 2021	9 th December, 2022
22.	Voter Polling Stations for the Member of Mahoo County assembly Ward in Taita Taveta County Assembly scheduled to be Held on 16th December, 2021	9 th December, 2022
23.	Appointment of County Returning Officer for clearance of the Deputy County Governor, Nairobi City County	1 st December, 2022
24.	Nominated Candidates for the By-Election of Member of County Assembly for Mahoo Ward in Taita Taveta County Assembly Scheduled to be held on 16th	1 st December, 2022
25.	Tallying Centre for the By-Election of Member of County Assembly for Mahoo Ward in Taita Taveta County Assembly scheduled to be held on 16th December, 2021	1 st December, 2022
26.	ate of By-Election for Member of the County Assembly for Kiagu Ward- Meru County scheduled to be held on 16th December, 2021. Uploaded on: Wed 27th Oct, 2021 No of downloads: 0	27 th October, 2022
27.	Appointment of Registration Officers and Assistant Officers Appointment of Registration Officers and Assistant Registration Officers for purposes of Registration of Kenyan Citizens residing outside Kenya Registration Centres for the registration of kenyan citizens residing outside kenya The Election (Registration of Voters) Regulations Corrigenda - The Election (Registration of Voters) Regulations - Registration Centres	17 th January, 2022
28.	Re-Allocation of Special Seats - Nominated Member to the Senate - Corrigenda	24 th September, 2021
29.	Gazette Notice No. 8166 - Persons Scheduled to Participate in the Party Primary for Maendeleo Chap Chap Party scheduled to be held on 16th August, 2021 Gazette Notice No.8167 - Persons Scheduled to Participate in the Party Primary for United Democratic Alliance Party scheduled to be held on 14th August, 2021 Gazette Notice No.8168 - Persons Scheduled to Participate in the Party Primary for Wiper Democratic Movement—Kenya Party scheduled to be held on 13th August, 2021	18 th August, 2021
30.	Nominated Candidates for Members of County Assemblies for Kiagu Ward in Meru County Assembly and Nguu/Masumba Ward in Makueni County Assembly scheduled to be held on 14th October, 2021 2. Declaration of No Contest for Eldas Ward Wajir County Assembly By-election scheduled to be held on 14th October, 2021 3. Certifying that the Revision of the Register of Voters for the By-	10 th September, 2021

S/NO	GAZETTE NOTICE (DESCRIPTION)	DATE OF PUBLICATION
	Elections scheduled to be held on 14th October, 2021 has been completed 4. Voter Polling Stations for the By-elections scheduled to be held on 14th October, 2021 5. Tallying Centres for the By-Elections scheduled to the held on 14th October, 2021	
31.	By-election for Member of the County Assembly for Mahoo Ward in Taita Taveta County Assembly scheduled to be held on 16th December, 2021.	26 th September, 2021
32.	Appointment of Returning and Deputy Returning Officers for purposes of the By-Election of Member of Mahoo Ward in Taita Taveta County Assembly scheduled to be held on 16th December, 2021 Appointment of Registration Officers and Assistant Registration Officers Registration Centres	17 th October, 2021
33.	Revocation of the Notice of Contributions and Spending Limits for Political Parties and Candidates for purposes of the General Election scheduled to be held on 9th August, 2022	9 th October, 2021
34.	Persons Scheduled to Participate in the Party Primary for United Democratic Alliance Party scheduled to be held on 16th October, 2021	18 th October, 2021
35.	Declaration of the Person Elected as Member of Nguu/Masumba Ward in Makueni County Assembly during the By- election held on 14th October, 2021. Corrigenda - Registration Centres	23 rd October, 2021

Annex 7: Map Requests

No.	Requester	Title of Letter	Recieve	Response Date
1.	Jacqueline Sipalla	Kajiado County Maps	22 June 2022	30 June 2022
2.	Prof. Robert Gateru	Request for Topographical Maps for Academic Research in Selected Cointies in Kenya	24 May 2022	10 June 2022
3.	Jacob Opara	Request for Busia County Map	19 May 2022	20 May 2022
4.	Diana Gakii Mutungi	Request for a Copy of the Langata Constituency	Undated	19 May 2022
5.	Sen. Mutula Kilonzo Junior, CBS	Request for Geographical Maps of Makueni County	22 April 2022	10 May 2022
6.	Cindy Mwendwa	Request for Detailed Physical Map of Dagoretti North Constituency	06 May 2022	10 May 2022
7.	Stephen Wanjohi Gitahi	Request for Maps of Adminstrative Areas and Political Division	25 April 2022	27 April 2022
8.	Dennis Mwangi Waweru	Request for Map and Location of All Polling Stations In Kasarani Constituency	22 April 2022	27 April 2022
9.	Simon Kamau Maina	Map for Gitaru Ward in Kabete Constituency, Kiambu County	30 March 2022	22 April 2022
10.	Peter Kiama	Request for Maps	11 March 2022	04 April 2022
11.	Titus Musyoka	Request for Kitetu/Kisau Ward Map 0414	21 March 2022	29 March 2022
12.	Erastus C. Mwangi	Map Request for Boundary Plan n0541/45-Naivasha Municipality	03 March 2022	18 March 2022
13.	Ludvic Punya	Map Request for Ngara Ward	03 March 2022	14 March 2022
14.	Lawrence K.S. Wachira	Maps for Wards, Constituencies and Counties	01 March 2022	02 March 2022
15.	Hon. Zuleikha J. Hassan	Polling Station Maps for Kwale County	28 February 2022	01 March 2022
16.	Amb. Ngovi Kitau	Request for Counties, Constituencies and Ward Maps for kenya	Undated	01 March 2022
17.	Mark Taylor	Map of Harambee Ward	02 February 2022	01 March 2022
18.	Henry Waweru Chege	Request for the map of Nkaimurunya Ward Which is in Kajiado North Constituency Kajiado County	14 February 2022	28 February 2022
19.	Wayne Ong'ara	Request for Electoral Map Kilimani Dagoreti North	04 January 2022	27 January 2022
20.	Daniel Tresvant Odera	Voter Information-Map Statics Names and Wards Data Mathare Constituency	12 January 2022	17 January 2022
21.	Annabel Njoki Mwangi	Electoral Maps and voter register	04 January	17 January 2022

No.	Requester	Title of Letter	Recieve	Response Date
			2022	
22.	Quinto Nalugala	Matayos Community Consultative Forum	13 December 2021	02 December 2021
23.	Buxton Odiwuor Diang'a	Boundary dispute between Kabondo East/West	11 November 2021	02 December 2021
24.	Awal Khalif Hussein	Request for an establishment of a Polling Station/Centre at Languyato Village in Afweine Location in Baraki Ward- Lagdera Constituency in Garissa County.	18 August 2021	14 October 2021
25.	Hon. Catherine Waruguru	Request for establishment of a Polling Station	30 July 2021	14 October 2021
26.	Moyale Community	Request for additional Polling Centres in Moyale Constituency	12 July 2021	14 October 2021
27.	John Simiyu Nabibya Wamuini- B Community	Request for additional and Gazzetment of a new Registration/Polling Station at either "Pefa Church Mabonde or Amani Friends Church- Mabonde of Love Mercy Academy Primary Scool- Tawai" in Wamuini-B Area Kamini Ward.	05 August 2021	14 October 2021
28.	The Majority Residents	Boundary Delimitation of Barsombe Nyakaimbi Farm	05 May 2021	12 October 2021
29.	Residents of Muthanga Farm	Historical Boundary Relocation & Polling Stations For Muthanga Farm	16-Sep-2021	12 October 2021
30.	Hon. Ahmed Kolosh Mohamed	Creation of new Polling Centre	18 August 2021	12 October 2021
31.	Andrew Mola Ilere	Information Regarding "Ngaremara" Special Ward in Isiolo/Meru County	9-Sep-2021	12 October 2021
32.	Micheal Otieno	Request for a Polling Station in Central Sakwa Ward	2-Sep-2021	13 October 2021
33.	Hon. Omar Mohammed Maalim	Additional Polling Centres	17 August 2021	12 October 2021
34.	Abdirauf Sheikh Hussein	Request for an establishment of a Polling Station/Centre at Wayama Sub Location in Maalimin Ward- Lagdera Constituency of Garissa County	17 August 2021	12 October 2021
35.	Bunyore Community	Request for a Constituency and determining the boundary of Vihiga, Kisumu & Siaya Counties	16 July 2021	20 September 2021
36.	Njuri Ncheke ya Meru Council of Elders, Maara Subcounty	Regularisation of boundary between the Mwimbe and Igoji Sub tribes of the larger Meru Tribe.	28 July 2021	15 September 2021
37.	R. Miruka & CO. Advocates	Infringement of Constitutional Rights of members of Naarolong Sub Location Keyian Ward in Transmara West , Narok	09 August 2021	20 September 2021
38.	Ministry of Transport,	Delienation of boundaries of urban areas in Bomet County	22 July 2021	08 August 2021

No.	Requester	Title of Letter	Recieve	Response Date
	Infrastructure , Housing, Urban Development and Public Works			
39.	Gwasssi North Location of Elders	Fixing new administrative units' in Gwasssi Division ; Suba South Sub county	24 May 2021	22 July 2021
40.	Tom Ogutu	Request for appointment with CEO	24 June 2021	29 June 2021

Annex 8: Election Data Request

No.	Nature of Request	Date
1.	Request of Voters List of Samburu County	18/03/2022
2.	Request for National Election Outcomes for 2013 & 2017 Elections	22/10/2021
3.	Request for Chuluni CAW Election Results for 2017 Election	19/10/2021
4.	Request for forms 36B & 39C for Narok County for the 2013 and 2017 Elections	13/10/2021
5.	Request for the inclusion of new Polling Stations in Mandera North Constituency	14/10/2021
6.	Request for National Election Outcomes for 2013 & 2017 Elections	05/10/2021
7.	Request for IEBC to take part on COVID-19 and Elections by the International Electoral Integrity Project Survey	19/07/2021

Annex 9: List Of Training Manuals Reviewed

<ul style="list-style-type: none"> • Polling Station Diary • Presiding Officers Quick Guide • CRO Quick Guide • RO Quick guide • Tallying Center Guide • Nomination and Registration Manual • Election Agent's Manual • Election Communication Center Guide • Elections Results Management Framework 	<ul style="list-style-type: none"> • Electoral Training Policy • Election training Curriculum • Framework for Candidate Registration Management System • Conduct of External Election Guide • Elections Handbook • Post-Elections Guide • Election Compendium
---	--

Annex 10: Accredited Voter Education Providers

S/NO.	NAME OF ORGANIZATION	ACCREDITATION CERT NO.
1	Panafro Disaster Brigade Institute	IEBC/VEP/2022/138
2	Petfrash Agencies Limited	IEBC/VEP/2022/143
3	Inter-Religious Council of Kenya	IEBC/VEP/2022/146
4	Nyakwerigeria Disabled Self Help Group	IEBC/VEP/2022/152
5	Eshinamwenyuli Youth CBO	IEBC/VEP/2022/154
6	Human Rights and Information Forum	IEBC/VEP/2022/157
7	Centre for Identification, Empowerment And Protection (CIEP)	IEBC/VEP/2022/158
8	African Girl International	IEBC/VEP/2022/159
9	Diasol - Diaspora Solutions Kenya Ltd	IEBC/VEP/2022/163
10	Kenya Veterans For Peace	IEBC/VEP/2022/164
11	Association for The Physically Disabled of Kenya (APDK)	IEBC/VEP/2022/168
12	Run to Serve	IEBC/VEP/2022/169
13	Glory Outreach Assembly	IEBC/VEP/2022/170
14	Pius Masai & Associates Consortium (Pimac International)	IEBC/VEP/2022/172
15	Kuza Livelihood Improvement Projects	IEBC/VEP/2022/173
16	Domineer HR Services	IEBC/VEP/2022/175
17	Kapletundo Triangle Investment Association	IEBC/VEP/2022/179
18	Friends of Redhill	IEBC/VEP/2022/181
19	Wahundura Eagles Self Help Group	IEBC/VEP/2022/189
20	Samburu Empowerment Network	IEBC/VEP/2022/190
21	Africa Grassroots Empowerment Foundation (AGEF)	IEBC/VEP/2022/196
22	Consuldata And Research Centre	IEBC/VEP/2022/197
23	Women Volunteers For Peace	IEBC/VEP/2022/198
24	Fast Track Computer Centre	IEBC/VEP/2022/202
25	Deaf Women Empowerment	IEBC/VEP/2022/205
26	Drum Major Media	IEBC/VEP/2022/208
27	Jiinue Keringet Youth Group	IEBC/VEP/2022/210
28	Tujikaze Humanitarian Programme (THUMP)	IEBC/VEP/2022/211
29	Muslims For Human Rights (MUHURI)	IEBC/VEP/2022/214
30	Epuka Ugaidi Organisation	IEBC/VEP/2022/217
31	Fellowship of Christian Unions of Kenya	IEBC/VEP/2022/223
32	Saden Community Based Organization	IEBC/VEP/2022/224
33	Ardha Jabesa Foundation	IEBC/VEP/2022/227

S/NO.	NAME OF ORGANIZATION	ACCREDITATION CERT NO.
34	Nazarene Group of Companies Limited	IEBC/VEP/2022/234
35	Marikwo Self Help Group,	IEBC/VEP/2022/236
36	Youth Intercommunity Network	IEBC/VEP/2022/237
37	Sisiti Community Based Organization	IEBC/VEP/2022/238
38	Asal Community Empowerment	IEBC/VEP/2022/239
39	Shinz Stanz Limited	IEBC/VEP/2022/241
40	Diaspora Wings Company Limited	IEBC/VEP/2022/243
41	Kenya Institute of Foreign Languages And Professional Studies (Kiflaps)	IEBC/VEP/2022/244
42	County Governance Watch	IEBC/VEP/2022/246
43	Pawa Africa	IEBC/VEP/2022/247
44	Bridgeway Counselling Institute	IEBC/VEP/2022/248
45	Islamic Aid and Social Care Organization	IEBC/VEP/2022/249
46	The People Transformation And Development Aid	IEBC/VEP/2022/250
47	Leadership Dialogue Network Foundation	IEBC/VEP/2022/252
48	Keepers Consultants Limited	IEBC/VEP/2022/001
49	Progressive Youth Group PYG	IEBC/VEP/2022/003
50	Eaglekwin Computer Solution	IEBC/VEP/2022/007
51	Center For Development and Peace	IEBC/VEP/2022/008
52	The Demography Project	IEBC/VEP/2022/010
53	Rufmo Consulting And Investments Co. Ltd	IEBC/VEP/2022/011
54	Desdemona Consulting Group Limited	IEBC/VEP/2022/012
55	Marvoco Digi Community Based Organization	IEBC/VEP/2022/014
56	Shecom Interpreters Agency	IEBC/VEP/2022/016
57	Life Pillars Christian Centre	IEBC/VEP/2022/018
58	Acme Development Organization	IEBC/VEP/2022/021
59	Nyandarua Interfaith Council	IEBC/VEP/2022/023
60	Intsimi Consult Ltd	IEBC/VEP/2022/025
61	Agency For Cross Border Pastoralists Development(APAD)	IEBC/VEP/2022/029
62	Worthy Vision	IEBC/VEP/2022/030
63	Organization of African Youth	IEBC/VEP/2022/031
64	Forum For Women Rights And Dignity (FORWORD)	IEBC/VEP/2022/034
65	Speak Logic Group Limited	IEBC/VEP/2022/035
66	Council Of Ward Administrators of Kenya (COWAK)	IEBC/VEP/2022/036
67	Siasa Place	IEBC/VEP/2022/037
68	Busia County Voters Forum	IEBC/VEP/2022/038

S/NO.	NAME OF ORGANIZATION	ACCREDITATION CERT NO.
69	Motech Logistic Limited	IEBC/VEP/2022/040
70	Kenya National Council of Elders Diaspora	IEBC/VEP/2022/041
71	Pokwise International	IEBC/VEP/2022/042
72	Global Peace Foundation Kenya	IEBC/VEP/2022/043
73	Action Network For The Disabled (ANDY)	IEBC/VEP/2022/044
74	Smsairworks Bulk Ltd	IEBC/VEP/2022/045
75	Uraia Trust	IEBC/VEP/2022/046
76	Community In Action Institute	IEBC/VEP/2022/052
77	Badili Africa Initiative	IEBC/VEP/2022/054
78	The Anglican Church Of Kenyan (ACK)	IEBC/VEP/2022/058
79	Jiinue Keringet Youth Group	IEBC/VEP/2022/059
80	Bethel Media Services Limited	IEBC/VEP/2022/063
81	Lamu Women Alliance	IEBC/VEP/2022/065
82	Mindspill Creatives	IEBC/VEP/2022/066
83	Back To Society Organization	IEBC/VEP/2022/067
84	Everest Media And Planning Solutions Limited	IEBC/VEP/2022/069
85	Leadership Dialogue Network Foundation	IEBC/VEP/2022/071
86	Octopizzo Foundation	IEBC/VEP/2022/075
87	Thomson Self Help Group	IEBC/VEP/2022/080
88	Article 19: Global Campaign For Free Expression	IEBC/VEP/2022/086
89	Transcooper Technology Kenya	IEBC/VEP/2022/088
90	Estword Youth Age Company	IEBC/VEP/2022/093
91	Task House Consultants Limited	IEBC/VEP/2022/096
92	African Social Development Focus (ASDEF)	IEBC/VEP/2022/098
93	Mwangaza Advertiser Co. Limited	IEBC/VEP/2022/102
94	Lanaken Company Ltd	IEBC/VEP/2022/107
95	Apir Turkana	IEBC/VEP/2022/109
96	Hadeche Agency	IEBC/VEP/2022/112
97	Community Peace Foundation	IEBC/VEP/2022/113
98	Lubao Frequency Modulation Ltd (LUBAO FM)	IEBC/VEP/2022/118
99	Kenya Institute Of Special Education	IEBC/VEP/2022/119
100	The Nasio Trust	IEBC/VEP/2022/121
101	Bomet Peace Ambassadors	IEBC/VEP/2022/122
102	Ekialo Kiona CBO	IEBC/VEP/2022/123
103	Homabay County Peace Network	IEBC/VEP/2022/128
104	Nguvu Moja Karima Youth	IEBC/VEP/2022/129
105	Integrated Development Facility	IEBC/VEP/2022/131
106	Jubilant Stewards Of Africa	IEBC/VEP/2022/132
107	Women Empowerment Link	IEBC/VEP/2022/134

S/NO.	NAME OF ORGANIZATION	ACCREDITATION CERT NO.
108	Lake Victoria Basin Talent Development And Adolescent Health	IEBC/VEP/2022/136
109	Education For Africa	IEBC/VEP/2022/137
110	Health and Water	IEBC/VEP/2022/139
111	Nyabomoke Women Group	IEBC/VEP/2022/142