

42

① D/Committees



Cicilia Wakesho Sironka
Moidabi, Narok
Tel: 0714377660

Hon. Justin Muturi
National Assembly Speaker
Parliament Buildings
Harambee Avenue
Nairobi.

② CINONO
pls deaf
FA
23/11

02/01/2015

④ GAZEMBA
pls deaf
27/11

Dear Sir,

RE: REQUEST FOR INVESTIGATION INTO ESTATE OF THE LATE SIAMETO MUNGUTI: -1974 - 2014

Since 1974 when Siameto Munguti died at Ngong, Kajiado County, the family has been living in great poverty and distress. Conspiracy between the bar, the bench, the land registry officials, assisted by OCS, Ngong Police Station has supervised the selling of our inheritance while keeping us busy with incessant litigation in all types of forums, courts of law and physical ejection out of inherited estate. The Athman Salim group has been sponsoring thuggery on us from the time they discovered they can acquired cheap land by sheer might of money and cunningness.

We kindly request your good office to task the Parliamentary Committee on Lands and Housing to investigate the listed issues which mainly deal with contempt of senior judges by magistrates. Athman Salim Mohammed is the chief architect of destruction of our property through compromising magistrates E.C. Cheron, then of Milimani Commercial Court (Court Order 123 of 2006) and Joseph Karanja then of Kibera law court in trespass case 3576 of 2007, to insubordinate the High Court of Kenya and Court of Appeal. Other associates of Athman Salim Mohamed opted not to have their names included on the list due to their relationships with Professor Githu Muigai advocates as relatives; namely Andrew Gichamba Muigai and Peter Martin Gichamba. Richard Obara Ondieki, holder of fake title Ngong/Ngong/37107 is associated with advocate I.S.Nyaberi in forging fraudulent COURT ORDER NO. 123 of 2006. H.C.Odera, an advocate at Oraro & Associates is the brother of Lucas Odera Hajula, is holder of fake title Ngong/Ngong/42143. The two senior counsels have represented Nepruko and land grabbers on diverse occasions in all the aggression cases that have previously been filed against us. The two cases we are pursuing with ^{YOUR OFFICE} the police are not sub judice but the fake titles are still in use by Athman Salim Mohamed & 48 others in swindling innocent people.

It is surprising to us in that, the Chief Justices Gicheru and Mutunga know about the fraudulent Milimani Court case No. SRM 123 of 2006, through our numerous letters but never willing to act. Lady Justice Kalpana Rawal, whose COURT ORDERS IN SUCCESSION CAUSE 227 OF 80 was adversely affected by the

③ D/Committees
This is a matter touching
on a Court of Law. Refer
to Justice & legal affairs Committee.
Athman Lands
27/11

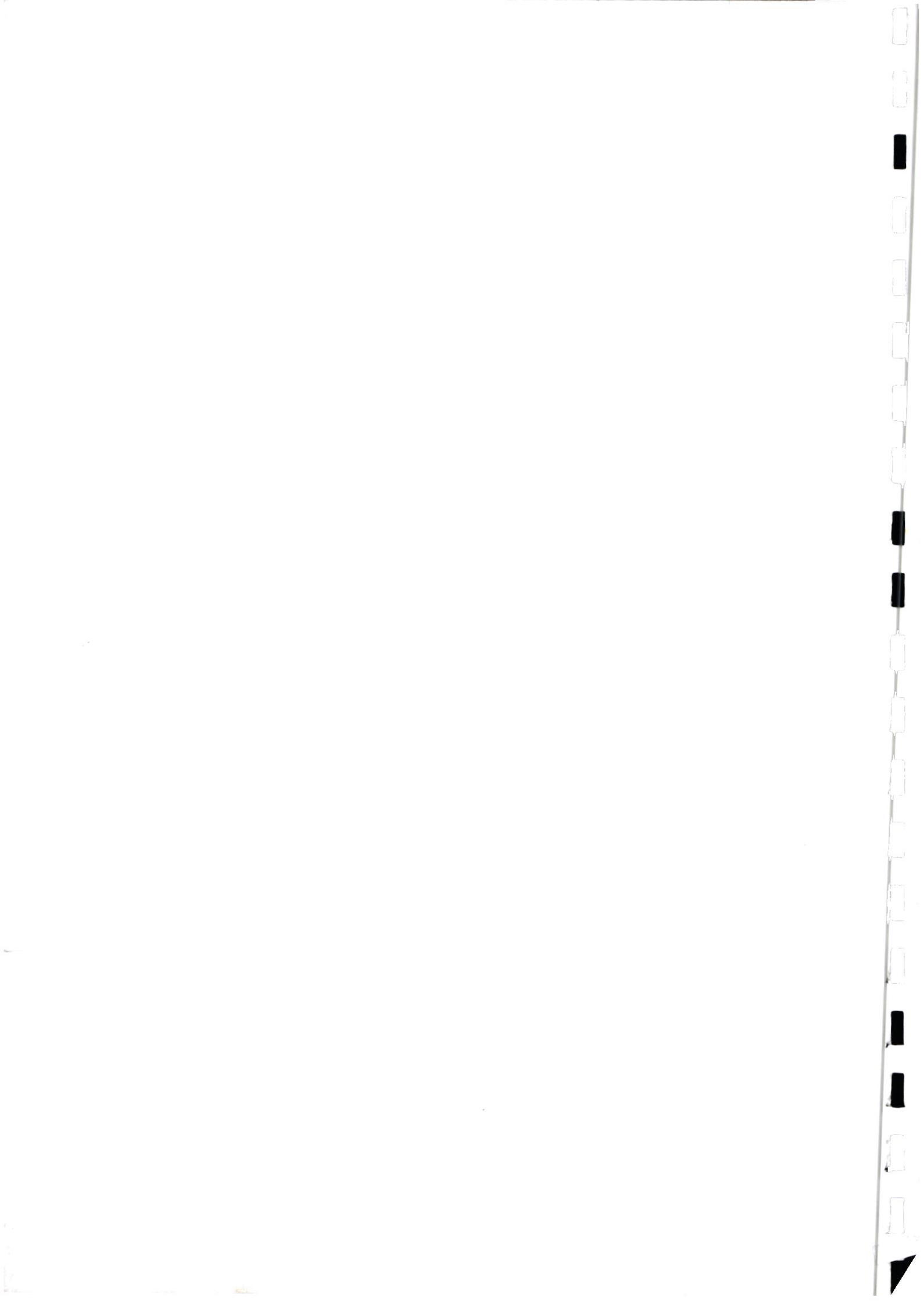

contemptuous Court Order 123 of 2006 and the equally contemptuous Kajiado District Land Registrar is also aware but did nothing. Inaction by the Chief Justice has turned COURT ORDER cautions removal at Kajiado land registry into big business. Lady Justice Nambuye is aware of Magistrate Joseph Karanja's and Kajiado land registrar destruction of EXHIBIT (Ngong/Ngong/37848) in Kibera trespass criminal case 3576 of 2007 even after getting all High Court documents. She only issued Order of Mandamus Certiorari in HCC. 33 of 2010. Under such circumstances, we are apprehensive of getting justice, given that Judiciary has given TOTAL STRANGERS (Athman Salim & 48 others) approval to sue us in succession cause 2395 of 2003.

Court of Appeal in case 272 of 2002 by Nepruko Munguti concluded that the cases 227 of 1980 was a family quarrel and did not entertain strangers. Our complaint is that the current judge of the Family Division of the High Court of Kenya, Nairobi is entertaining strangers Athman Salim Mohamed and his group of 48 others to belatedly harass us by filling the current cases. Athman Salim Mohamed group appears to get strange attention by the court. First, the judge gave two and half months for simple written submissions. At the appointed date for submissions, Senior Counsel Oraro for Athman Group asked for extension of time to highlight issues on his eight pages of submission. Strange enough, the judge gave him a further two and half months to 11th February, 2015. We have been advised by our advocates on record D.B.Wati that highlighting was simple and could have been done verbatim in the court for twenty minutes and finish the submissions by all three counsels.

In 2013, Athman Salim Mohamed and his associates filed a case in the Constitutional and Human Rights Division as case No. 154 of 2013 but were rejected as it was private matter. The same case was transferred to Environment and Land Division as Court case 432 of 2013 but was rejected. We request presiding judge of family Division 2395 of 2003 to rationalize why he granted Senior Counsel George Oraro two and half months until February 11, 2015 to highlight his eight pages of submissions. At this rate, the judiciary should never complain about unmanageable cases backlog as the burden can only increase unabated. The Judge is insensitive to us for we have been in and out of the courts for more than thirty five years. In fact, Oraro appeared in person on that particular day to represent Athman and 48 others as well as lawyers from his office who has bought resultant parcels of land. We viewed this action as meant to intimidation the judge. To our surprise, the judge never commented on anything Oraro said or suggested.

It was surprising to read in the X-press of a VENEZUELAN MEDIC WHO WAS FINED SH.8MILLION FOR MIAMI AIRPORT BOMB PRANK. To quote the only evening paper dated 2/12/2014 "Manuel Alvarado, 60, will pay sh.8.1 million for temporarily causing panic and evacuation and flight delays at Miami International Airport in October 22, 2014. Compare this with a judge who has

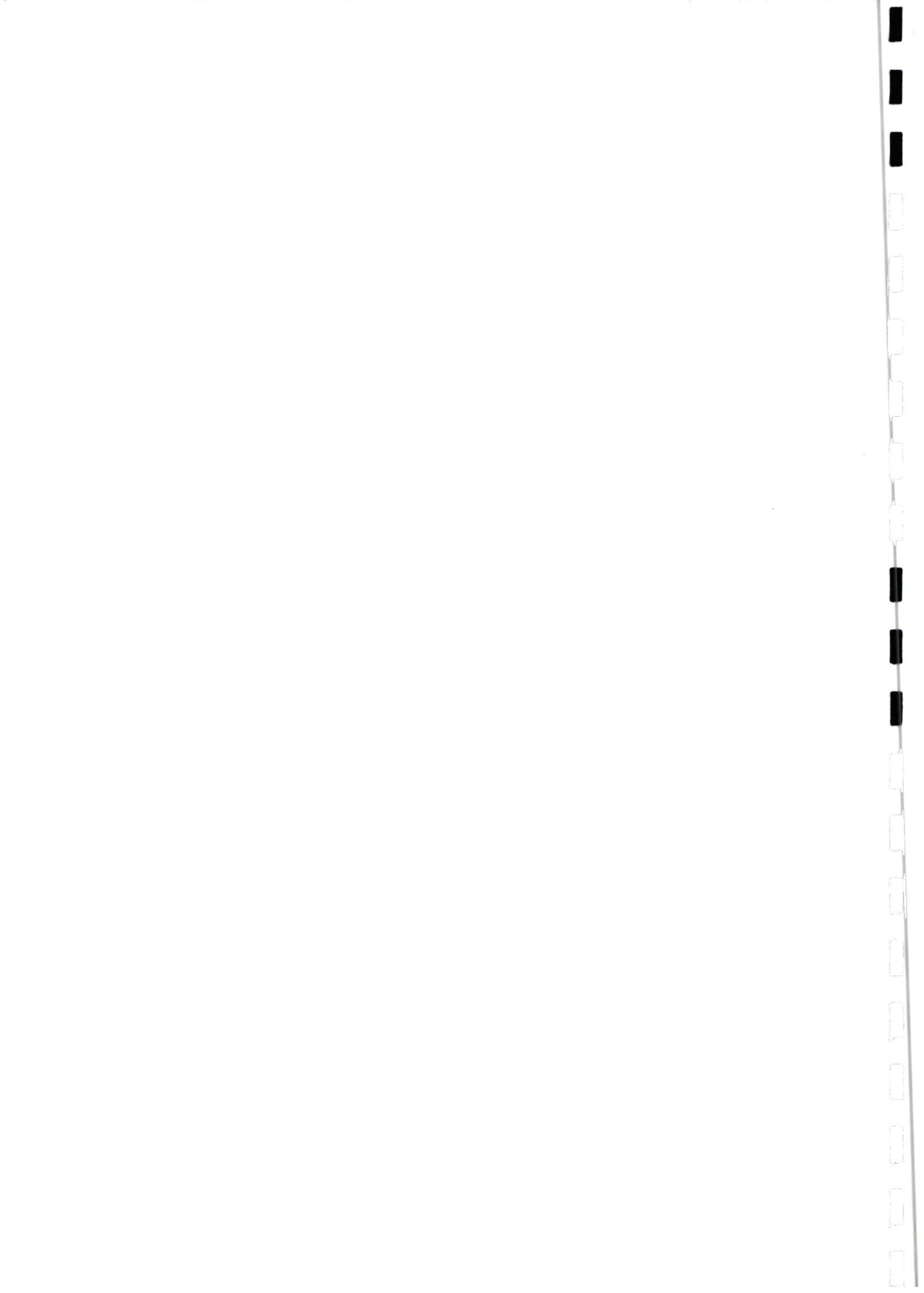

given senior counsel two and half months to summarize by highlighting his eight pages submissions.

The Chief Justice should not preach to Kenyans on alternative dispute resolution mechanism without tangible evidence it works. Kenyans go to courts as last resort and not as an alternative to corruption mechanisms. As seen on the documents attached herewith we have tried this route from 1974 to 1999, long before Athman Salim Mohamed and his group of land grabbers came to the scene in 2006. We have reported to the Chief Justice of his own junior officers at Milimani Commercial Court and Kibera law court and the Kajiado district land registrar's insubordination of the High Court of Kenya and the Court of Appeal since 2003 without success. The only information we get from judiciary is that "we should move the court to prove an abuse of the COURT". Why should we use our money to advise the High Court of its junior officer's insubordination of its authority?

OMBUDSMAN: - It is regrettable that the court is increasingly becoming inaccessible by erecting a barrier in the name of an ombudsman at the reception desk as well as the ever increasing cost in legal fees. The ombudsman is an expert in taking individuals through illusions of being helped thus that office is waste of public fund as well as personal money and time. Parliament should look into ways of disbanding this office from Kenya's legal system.

We make special appeal to Lands and Housing committee to interrogate the forgeries of Milimani Commercial Court Order 123 of 2006 and recommend prosecution by Directorate of Criminal Investigation. This is a special abuse of the High Court and Court of Appeal judges by advocate I.S Nyaberi, Simon Munguti and the kajiado district land registrar. To illustrate this, Kajiado district land registrar appeared before Justice Rawal on 6th February 2006 and agreed to revoke and cancel all the titles resultant from Ngong/Ngong/27. But he had earlier on 3rd February, 2006, made entries using the fake COURT ORDER 123 of 2006 and never removed them to date. We have made numerous written and verbal requests to the Chief Justice to no avail. We sought an advisory from the Law Society of Kenya, which came out quickly and positive.

It is sand for us that the court grants audience to any person willing to harass us through litigation and without adjudging the cost of the suits to our benefit. To illustrate that we deserve Parliamentary attention, we have compiled a detailed 143 pages document to illustrate the unfairness of the Judiciary.

Yours Faithfully

Cicilia Wakesho Sironka 



Attached document

1. THE LETTER TO THE SPEAKER OF THE NATIONAL ASSEMBLY
2. Death certificate of Siameto Munguti dated 1974
3. Succession cause 227 of 80 which now stands nullified
- 4 FAMILY DIDPUTE RESOLUTION MECHANISM FRO 1974 TO 1996
5. NGONG CHIEF'S OFFICE 1996 (*manuscript*)
6. KAJIADO DISTRICT LANDS TRIBUNAL 1997,
7. KAJIADO SENIOR RESIDENT MAGISTRATE COURT SRM 4/1999
8. Judiciary letter ref 15/1 VOL.XXX dated 24th November 2003
9. COURT OF APPEAL CAUSE 272 OF 2002 against 227/80 ruling.
10. CONFIRMATION OF GRANT, SUCCESSION CAUSE HCC 2395 OF 2003
11. JUSTICE DULU'S DISMISSAL OF NULLIFICATION APPLICATION 2395 OF 2003
12. ADVOCATE D.B WATI'S SUBMISSIONS IN SUCCESSION CAUSE 2395 OF 2003
13. LSK LETTER REF; - M3 DATED 3.6.2008 ON INSUBORDINATION OF HIGH COURT BY MILIMANI COMMERCIAL COURT IN 123 OF 2006
14. COURT SUMMONS DATED 2/2/2007 TO NEPRUKO AND LAND REGISTRAR TO SHOW CAUSE WHY THEY COULD NOT REVOKE AND CANCEL TITLES AS ORDERED
15. MILIMANI COMMERCIAL COURT CAUSE SRM 123 OF 2006
16. CTC OF GREEN CARDS OF TITLES CAUTIONED BY THE HIGH COURT AND ENTRY OF NULLIFICATION BY THE MAGISTRATE in 123 of 2006
17. KIBERA MAGISTRATE'S CRIMINAL COURT CASE 3576 OF 2007
18. NO CASE TO ANSWER SUBMISSIONS IN 3576 OF 2007
19. CAVEAT EMPTOR IN NATION NEWSPAPERS DATED 27TH NOVEMBER 2007
20. LETTER DATED 4/5/2008 TO ATTORNEY GENERAL, CHIEF JUSTICE EVAN GICHERU AND THE LAW SOCIETY OF KENYA ON ISSUES OF 123 OF 2006
21. THREE COPIES OF MUTATION NGONG/NGONG/37106, 37848 AND 40285 TO SHOW ILLEGAL SUBDIVISIONS AFTER RELEASE OF ORIGINAL TITLE EXHIBIT BY KIBERA BY COMPROMISED MAGISTRATE JOSEPH KARANJA.
22. MISCELLANEOUS ORDER OF MANDAMUS CERTIORARI HCCC 30 OF 2010
23. LETTERS DATED 16.09.2008, 10/09/2009 SHOWING THE DEFIANCE OF KAJIADO DISTRICT LAND REGISTRAR TO ORDERS OF THE HIGH COURT OF KENYA
24. LAND REGISTRAR; P. NYAMWEA'S AFFIDAVIT TO CANCEL ALL TITLES THAT RESULTED FROM ILLEGAL SUBDIVISION OF NGONG/NGONG/27
25. COURT ORDER CAUSE 2395 OF 2003, DATED 26/3/2012 TO CANCEL ALL ABOVE TITLES AND ISSUANCE OF TITLES TO BENEFICIARIES ON CONFIRMATION OF GRANT.
26. APPLICATION TO CONSENT OF OLOOLAISER LAND CONTROL BOARD TO SUBDIVIDE NGONG/NGONG/27. CONSENT LCR NO.128/9/2012 GIVEN TO IMPLEMENT SUBDIVISION.



28. RL7 FORMS FOR TRANSFERRING RESULTANT PARCELS TO BENEFICIARIES AS RECOMMENDED IN CONFIRMATION OF GRANT 2395 OF 2003.
29. LETTER PETITIONING CHIEF JUSTICE, DIRECTOR OF PUBLIC PROSECUTIONS, KENYA ANTI-CORRUPTION COMMISSION AND KAJIADO COUNTY GOVERNMENT AND KENYA NATIONAL COMMISSION ON HUMAN RIGHTS TO INVESTIGATE CRIMINAL MILIMANI COMMERCIAL ORDERS 123/2006 AND KIBERA TRESPASS CASE 3576 OF 2007.
30. JUDICIARY REFERENCE CARD NO.1017506 AND KENYATTA NATIONAL HOSPITAL INVOICE FOR LEDAMA SIRONKA 13 YEAR WITH KIDNEY PROBLEMS
31. LETTER DATED 26/8/2014 ASKING JUSTICE MUTUNGA TO INVESTIGATE MAGISTRATE E.C. CHERONO FOR MILIMANI COMMERCIAL ORDER 123 OF 2006.
32. LETTER REF: - KM/413/12 DATED 11/10/2012 FROM ONE OF OUR ADVOCATES TO KENYA POWER FOR ILLEGAL CONNECTION OF POWER ON OUR LAND.
33. LETTER DATED 18/6/2014 TO KAJIADO GOVERNOR NKIDENYE REQUESTING DEMOLITION OF ILLEGAL STRUCTURES ON OUR RESPECTIVE PARCELS OF LAND.
32. CONSTITUTIONAL & HUMAN RIGHTS COURT 154 OF 2013 (*THROWN OUT*)
33. Environment and Land Court NAIROBI 432 OF 2013 (*THROWN OUT*)
34. SUCCESSION CAUSE HCC 2395 OF 2003(THE JUDGE HAS ALLOWED ATHMAN SALIM MOHAMED AND 48 OTHERS AND SIMON MUNGUTI TO FILE TWO APPLICATION FOR PETITIONS TO NULLIFY HCC 2395 OF 2003)
35. COPIES OF GREEN CARDS FOR RELATIVES OF GITHU MUIGAI (ANDREW GICHAMBA MUIGAI AND PETER MARTIN GICHAMBA) AND RELATIVES. C. ODERA WHO IS AN ADVOCATE IN THR FIRM OF ORARO AND ASSOCIATES (CHACHA ODERA)
36. LETTER FROM ORARO AND COMPANY ADVOCATES SHOWING NAME OF ODERA WHO IS BROTHER OF ODERA THE LAND GRABBERS



REPUBLIC OF KENYA

B No 669122

CERTIFICATE OF DEATH

Death in the		KAJIADO		District in the		RIFT VALLEY		Province	
Entry No.	1000276	/	74	Name and Surname of Deceased		Siameto Munguti			
Sex	Male	Age	60 Yrs	Occupation	Businessman				
Date of Death	29th Oct. 1974		Place of Death	Ngong		Residence	Kajiado		
Cause of Death	Heart failure Fatty degeneration of heart, flund liver.								
Name and Description of Informant	Dr. A.L. Ribeiro		Name of Registering Officer	J. Pasha		Date of Registration	31st Dec. 1974		

I, Willie Kabue District/Assistant

Registrar for Kajiado District, hereby certify that this certificate is compiled from an entry/return in the Register of Deaths in the District.

[Signature]
 Assistant Registrar

Given under the Seal of the Principal Civil Registrar on the 5th day of June, 2002

This certificate is issued in pursuance of the Births and Deaths Registration Act (Cap. 149) which provides that a certified copy of any entry in any register or return purporting to be sealed or stamped with the Seal of the Principal Civil Registrar shall be received as evidence of the dates and facts therein contained without any or other proof of such entry.

1





REPUBLIC OF KENYA

IN THE HIGH COURT AT NAIROBI

PROBATE AND ADMINISTRATION CAUSE 227 OF 1980.

Administration of Estate of Siameto Ole Munguti
Deceased

BE IT KNOWN that on the 9th day of December, 1980.

letters of administration intestate

of all and singular the property and credits of Siameto Ole Munguti

aforesaid

late of Kajiado in Kenya

deceased, who died on the 29th day of October, 1974

at Ngong' in Kenya intestate, were granted by this Court

to Hepruko Munguti Siameto of P.O. Box 78

Ngong' Hill in Kenya the deceased's widow

the ~~of the said intestate~~ he/she/it/they having undertaken well and faithfully to administer the same and to make a full and true inventory of the said property and credits and exhibit the same in this Court within six months from the date of this grant or within such further time as the Court may from time to time appoint, and also to render to this Court a true account of the said property and credits within one year from the same date or within such further time as the Court may from time to time appoint.

Dated this 9th day of December, 1980

[Signature]

Judge, High Court of Kenya

S



CASE BETWEEN OLEMUNKUTI'S FAMILY DONE ON
7TH NOV 1996 AT CHIEF'S OFFICE NGONG

PRESENT:

- SENIOR CHIEF - WILSON TULITO.
- ASSISTANT CHIEF - BENSON WAKARA.
- " " - BERNARD MEREU.
- ELDER - PAUL WAKARA.
- " - DOMINIC NBIATAI.
- " - MIRIABEI NYITERA.
- " - MARY KUTSUI.
- " - JACKSON DIKIR.
- " - RAPHAEL LEINSO.
- WIFE - RESIAID MUNKUTI.
- " - NONKIPA MUNKUTI.
- " - NEDRUKO MUNKUTI.
- SON - KESIWE OLEMUNKUTI.
- " - SIMIRAN OLEMUNKUTI.
- " - MICHAEL SIRUKA OLEMUNKUTI.
- " - BENSON KEMERIAN OLEMUNKUTI.
- " - KENNEDY PARSIMEI OLEMUNKUTI.
- " - SARUNI OLEMUNKUTI.
- DAUGHTER - SIALO MUNKUTI.
- DAUGHTER IN-LAW - NYAMBURA SIMON MUNKUTI.
- ELDER - PETER MUIRURI.

The meeting was opened with a word of prayer.

CHAIRMAN

He started by cautioning the panel to observe respect while the case is in session.

1ST COMPLAINANT (RESIAID MUNKUTI)

I have come to see my late husband's property. I leave at Mosiro, initially I was living with my late husband at home but later he asked me to return to Mosiro to take care of my elderly mother in law and the broths in-law. I have few animals at Mosiro, in that case I was never separated from my late husband and that the animals I have at home nobody so far has come to claim.

3



- Washaya Rutei (former chief)
- Ngori (former chief)
- Paramour chief (late)
- Joseph Bluebocker (former chief)

arrived in presence of late Mbayu Sakada
 to place the properties under my name. The decision
 in Ngori die but under my name. All the
 complainant are my co-wife but all the
 loss of their husband burial. I agree that
 has since and since they never even come
 to me for each wife had his property there.
 them to sue Githig. Whatever is in Ngori be
 and the wife took 5 heads of cattle and
 share of livestock. My wife took 4 heads of cattle
 came for home blessing and demanding their
 even after I did but bus fare, they late
 died, the complainant didn't respond immediately
 found no wife at home. When my late husband
 when I was married to my late husband

DEFENDANT (Mrs NEPVEDO MUKWISI)

found the case completed
 and that when the 3rd wife was married,
 I also took part in the construction of the
 took but and two cows, 3 goats took
 and divided the amount as three
 After his death he gave and blessed the
 he still had construction with him until his
 my father at Narieta Nkari but despite the
 to divorce with my late husband, I later
 a house build by our late husband, I later
 and later moved to Kibiko where we had
 married, we were living at Sakaba's
 (is land business plot). When the 3rd wife
 also come to see my late husband's
 in the second wife of the late Mukwisi

2ND COMPLAINANT (MUKWISI)

2

4

4



SON (GESSINE MUNKUSI)

What made us delay in coming to late father's burial is due to the fact we had first had to find our gud mo whom we were living far apart. When we came for home blessing our third mother we to surrender my late father documents (re: deed Bank book. I took my mother's share cattle (Resiato) that is 3 herd of cattle only, I claimed the rest had died. When we came sharing our father's estate, by that time Chie iddi malambu was claiming the 3rd mother's

us. I later came visiting her and she welcomed. What I'm now telling you elders is that the animals I was herding are the ones that were sold by my late father and the proceeds was used in constructing the shop, we are staying in a state land.

Question

The chairman asked the complainant a demand, they listed as follows-
1) land
2) Shop
3) Money in the

SON (SIMIRAN MUNKUSI)

I'm the Munkuti's son. When my mother (NONKIPA) left to my grandfather's home, my late father came to visit us and took us to school and was providing me with all my requirements.

SON (KENNEDY MUNKUSI)

I'm Munkuti's son we had lead a very difficult life but despite that we were able to recognize our late father, so in view of that we are requesting the elders to assist us in sharing our father's property fairly.



PAUL WAKABA (ELDER)

(4)

I know Munkuti's family very well in childhood for we have been living together in my late father's home. I know the three (3) of Munkuti's wives and they are all legally the late

BENSON WAKABA (ASS. CHIEF)

I share the same sentiments with my brother Paul and that fairness should be done to all parties concerned.

CHAIRMAN

Before the judgement, I will first call the elders who were involved with the case initially to verify whatever transpired when they were dealing with the case in question and that letters will be written to them to notify them. After short deliberation, 19/11/96 was set for next hearing. The case was then adjourned.

19th Nov. 1996.

CASE CONTINUATION

The case was opened with a word of prayer from one of the elders. The Secretary read the minutes and were confirmed as true.

MATTERS ARISING

Siriran Olemunkuti indicated that he had mentioned in his statement that when they were given the cows, they were informed to come back for other property when all the children are mature. Paul Lenteja also indicated that during their stay with Munkuti's family, he fell sick and was admitted when he was discharged, he only found the 3rd wife (reput)

2.



(5)

PRESENT

- SENIOR CHIEF WILSON TULLIO
- ASST. CHIEF BENSON WAKARA
- " " BOMARD MEXEN
- CHIEF (RTO) WASHAIYO PULEI (CHAIRMAN)
- CHIEF (RTO) NYURI - ELDER
- LONUISA MONKUTI - SON
- LENDIKA OLENAITARA - ELDER
- MIRIABEI OLENAITARA - "
- CAPTAIN (RTO) MICHAEL NYIKIR - ELDER
- PAUL WAKARA - ELDER
- RADHACH LEMISO - "
- PARAMOUNTI IDAI HASSAN -
- JACKSON DIKIR - ELDER
- MARY KUSASO - "
- NEPEKO MONKUTI - 3rd wife.
- NYUKIPA MONKUTI - 2nd wife.
- RESIHO MONKUTI - 1st wife.
- SIARO MONKUTI - DAUGHTER.
- SARON " - SON.
- K. PARSIMEI " - SON.
- B. LEMERIAN " - SON.
- M. SIRUNKA " - SON.
- SIMIRAN " - SON.
- KESIWE " - SON.

The former Chairman Senior Chief Wilson Tullio handed over the chairmanship to the Chief (RTO) Washaiyo Pulei

(CHAIRMAN (PULEI))

I'm president of Nōung having lived here for about time I know the Olemunōtis family has present in the building of the shop and of the area. He had asked the complainant whether the deceased had properties in this area of living and they confirmed affirmative then the H. was decided that each wife should get with whatever she has.

7



Question - Eivise Munkit then asked the Chairman whether further investigation had been done by the eyes to ascertain the position of the properties in question? and Chairman - No investigation has been done. Then I would like to explain that further to what she herself came to claim his late father's properties.

Mrs Nyoro (Elder)

I know the Munkit's family. Since the family in Nyeri came to claim their deceased father's properties in Nyeri, he also understood that the Munkit's land properties in Masina and Euseburia. So he decided that every wife should take whatever has in her possession by the of the death of their husband.

Captain Ndiki (Elder)

The elders acted in the allocation for the land in Masina is undemarcated (group ranch) the land in Euseburia has and is still a state land and the wife settled there on her own and she received duty as doesn't give the land.

Parliament Chief Clerk

Whatever has been passed is for that was spoken by both for Pucc and Nyoro

NANCIPA MUKISI (2nd wife)

You asked later after your judgement that we should search out our notes. Munkit has no registered property in Nyeri. We live, we are all the family, we don't know of any court proceeding that need from you eyes is fact & judgement.



HIGH COURT OF KENYA NAIROBI

SUCCESSION CAUSE NOS 227 OF 1980

PROCEEDING:

KAJIADO LAND DISPUTE TRIBUNAL HELD ON 31/08/99

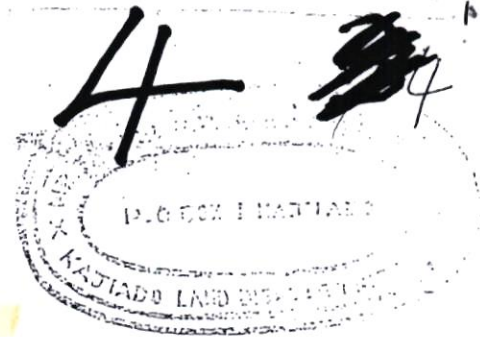

COMMITTEE MEMBERS

- | | |
|----------------------|--------------------|
| 1. SAMUEL P. PARMUAT | - CHAIRMAN |
| 2. GIDEON K. MARDADI | - COMMITTEE MEMBER |
| 3. ELIJAH KOIPITAT | - " |
| 4. SAMUEL NKAINA | - " |
| 5. MUHINDI | - SECRETARY |

LAND DISPUTE: NGONG/NGONG/27

1. NEPURKO SIAMETO MUGUTI (WIDOW)
versus
2. RIASIATO ENE MUGUTI ID 6152543 (WIDOW)
3. KAGUNI SIAMETO LEMUGUTI ID 019974 (WIDOW)

The land dispute tribunal committee arrived at the D.O.'s office Ngong at 1.00 p.m.

At exactly at 1.16 p.m. the Land dispute tribunal laready sitted at the office of Senior chief Mr. Wilson Ole Tulito.

PRESENT

- | | |
|--|--------------------------------|
| 1. Samuel P. Parmuat | - Chairman |
| 2. Gideon K. Mardadi | - Committee member |
| 3. Samuel Nkaina | - " |
| 4. Elijah Ole Koipitat | - " |
| 5. Resiato Munkuti | - First wife of the deceased. |
| 6. Noonkipa Munkuti | - Second wife of the deceased. |
| 7. Kerne Ole Munguti | First borne |
| 8. Michael Ole Ndikir | |
| 9. Paul Wanyoike (AP) i/c Ngong division. | |
| 10. Wilson Wakaba - Assistant chief Ngong township | |
| 11. Wilson Tulito Molil - Senior chief Ngong | |
| 12. Michael Sironka Munguti | |
| 13. Captain Maison Ole Ndikir | |

The meeting was opened with a word of prayer by Mr. Gideon K. Maridadi.



PROPERTIES CLAIMS

- 1. Equal share - Ngong/Ngong/27 Area covered 50.6 acres
- Stone 12 ~~Stop~~ Business plot at ngong township
- 3. Cash at Bank

Documents presented before the land dispute tribunal

1st meeting held on 7th November, 1996

2nd meeting held on 27th January, 1997

3. Succession cause Nos. 227 of 1980.

4. Photocopy of green card shows the deceased named Siameto Ole Munguti cancelled to Mrs. Nepurko Munguti Siameto. The 1st wife Resiato Munguti reported to the Tribunal how painful, it is when she remembers Nepurko claimed their land Ngong/Ngong/27 and misused all the livestock owned by her husband. She reported to the Tribunal, that, she is still agreed, to share Ngong/Ngong/27 with three of the deceased wives - with equal share namely:-

- 1. First wife Mrs. Resiato
- 2. Second wife Mrs. Noonkipa
- 3. Third wife Mrs. Nepurko

The second wife of the deceased Nookipa reported she agreed to share the Ngong/Ngong/27 with equal share among the three of them.

The elder son Mr. Kesne Ole Munguti reported, the land to be shared among the three wives of the deceased with equal shares. Assistant chief Mr. Benson Wakaba - Ngong Township reported to the tribunal, that, she knows the family of the deceased, and three ladies namely:-

- 1. Mrs. Resiato)
- 2. Mrs. Noonkipa) both are legally married to the
- 3. Mrs. Nepurko) deceased. and they should share
-) equally the properties.

Senior chief Mr. Wilson Tulito reported that, three ladies are wives of the deceased, and ^{all} ~~both~~ should share equally the properties of their dead husband.

LAND VISIT NGONG/NGONG/27

The tribunal visited to the disputed ground but unfortunately we did not stand on the disputed ground, but, we have been shown all the boundary at a far distance. We saw maize plantation and a huge virgin land covered with indigenous acacia trees and others.

RULING/JUDGEMENT/RESOLUTION

^{the} We are of opinion, that, Mr. Nepurko Munguti Siameto, is a criminal, she claimed the whole land known as Ngong/Ngong/27 without giving share to her co-wives. We arrived with a conclusion that the Ngong/Ngong/27 should be shared equally.

2



- 1. Mrs. Resiato be given 16.87
- 2. Mrs. Noonkipa be given 16.87
- 3. Mr. Nepurko be given 16.87

and they should share the Business plot at Ngong.

The Land Tribunal Committee, found it very painful, when, Nepurko Munguti, made succession of Ngong/Ngong/27 and Business Plot at Ngong Township alone, leaving behind Mrs. Resiato Munguti and Mrs. Nookipa Munguti children and their grand children to suffer and to be land less. Justice must be done to this family to bring peace. So equal shares is the only solution to this family.

on 13/09/1999 Miss Elizabeth Siola - reported her mother was sick the case postponed to 24/09/99.

AUTHORITY SIGNATURE

- 1. Samuel P. ParmuatSigned.....*elatt*.....Date 24/09/1999
- 2. Gideon K. MardadiSigned.....Date.....
- 3. Samuel NkainaSigned.....*P. Nkaina*.....Date 24.9.99
- 4. Elijah KoipitatSigned.....*Koipitat*.....Date 24.09/99.
- 5. MuhindiSigned.....*Muhindi*.....Date 24/09/99.

COPY

- Mrs. Resiato Munguti
- Mrs. Noonkipa Munguti
- Mrs. Nepurko Munguti
- Land Registrar - Kajiado
- Magistrate Court - Kajiado
- District Commissioner - Kajiado



10 5

IN THE SENIOR RESIDENT MAGISTRATE'S COURT AT KAJIADO

MISC. CIVIL SUIT NO. 4 OF 1999

1 RESUATO MURKUTI)..... APPLICANT
2 BOORUKIPA MURKUTI)

VERSUS

DEBURKO MURKUTI SIAMETO RESPONDENT

RULING

The respondent is absent though served. I have heard
for her award for the applicants and I order that the award by
Kajiado Land Disputes Committees dated 24/9 - 99 be and
is hereby adopted as judgement of the court there having
been no appeal preferred. Cost in cause and Right of appeal
28 days.

sd. NDUNGU H.N. (MISS) SRM

29-11-99

CERTIFIED TRUE COPY
OF ORIGINAL
MAGISTRATE

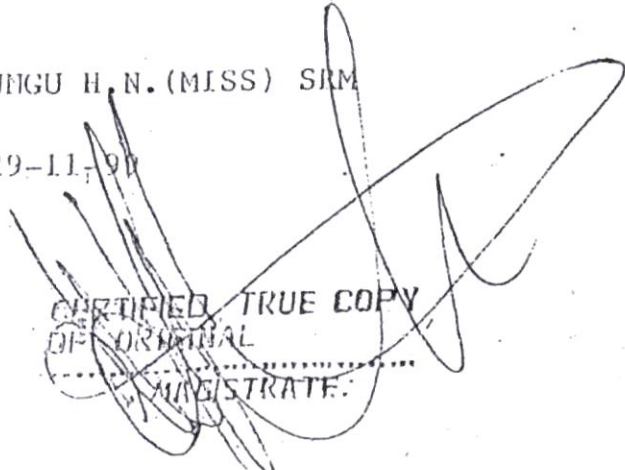

7 11



12 H

Telegram: "COURT", Nairobi
When replying please quote/



THE REGISTRAR'S CHAMBERS
HIGH COURT OF KENYA
LAW COURTS
P.O. Box 30041-00100
NAIROBI

15/1 VOL.XII
Ref. No.
and date

24th November, 2003

20

Siameto Munguti,
P.O. Box 32097,
NAIROBI.

**SUCCESSION CAUSE NO. 227/80 AND APPEAL CAUSE NO. 272/2002
COMPLAINT AGAINST KAJIADO DISTRICT LAND REGISTRAR
AND NEPRUKO MUNGUTI**

Thank you for your letter dated 20th November, 2003. I am afraid the Registrar cannot decide for you whether an act of contempt of court has been committed by a party to the suit. If you are satisfied that such an act has been committed, it is upon you to move the court for orders through an appropriate application.

I will revert to you later on the issue of the appeal case.

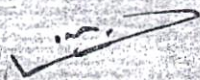
C. K. Njai
CHIEF COURT ADMINISTRATOR
FOR: REGISTRAR

cc: Mr. Martin Muya,
Senior Deputy Registrar,
Civil Division,
NAIROBI.

(Please let me know the position in this appeal).

15



13 8(a) 2
~~8(a)~~
P. & A. 41

Grant of Letters of Administration Intestate



REPUBLIC OF KENYA

IN THE HIGH COURT OF KENYA

AT NAIROBI

SUCCESSION CAUSE NO. H.C./RMX 2395 of 20. 03

In the matter of the Estate of SIAMETO OLE MUNGUTI Deceased.

BE IT KNOWN that on the 21ST JULY 20 04 letters of

Administration intestate of all the estate of SIAMETO OLE MUNGUTI

(also known as SIAMETO OLE MUNGUTI ALIAS SIAMETO MUNGITI

deceased late of NGONG IN KENYA who died domiciled in

THE REPUBLIC OF KENYA on the 29TH OCTOBER 1974

at KAJIADO which by law devolves to and vests in his/her personal representative

were granted by this Court to RESIATO MUNGUTI ALIAS RESIATO ENE MUNGUTI, NOONGIPA MUNGUTI

ALIAS KAGUINI SIAMETO MUNGUTI (and NEPRUKO SIAMETO MUNGUTI

of P.O. BOX 55, NAROK) he/they having undertaken faithfully to administer such estate

according to law and to render a just and true account thereof whenever required by law so to do.

ISSUED by the High Court/Resident Magistrate's Court through the registry at

NAIROBI IN KENYA this 21ST JULY 20 04

AMENDED AT NAIROBI THIS 8TH DAY OF MARCH 2006.

Signature *[Handwritten Signature]*

Judge of the High Court/

Resident Magistrate

THIS IS TRUE COPY OF
25/1/2006
[Handwritten Signature]

131

(8) 8



14 8(b) 2



REPUBLIC OF KENYA
IN THE HIGH COURT OF KENYA AT NAIROBI
SUCCESSION CAUSE NO. 2395 of 2003

IN THE MATTER OF THE ESTATE OF SIAMETO OLE MUNGUTI (DECEASED)

CERTIFICATE OF CONFIRMATION OF GRANT

I HEREBY certify that the above written grant of representation to the estate of the late
SIAMETO OLE MUNGUTI issued to
RESIATO MUNGUTI & NOONGIPA MUNGUTI
therein named has this 26TH SEPTEMBER 2005 been confirmed by the
Court pursuant to the provisions of section 71 of the Law of Succession Act.

Dated at Nairobi this 26TH DAY OF SEPTEMBER 2005

SCHEDULE

<u>Name</u>	<u>Description of Property</u>	<u>Share of Heirs</u>
	L. R. NO. NGONG/NGONG/27	
Noongipa Munguti		2.0 acres
Patrick Simiren Munguti		2.0 acres
Michael Sironka Munguti		2.0 acres
Kennedy Parsimei Munguti		2.0 acres
Benson Lemeria Munguti		2.0 acres
Samuel Fuseo Munguti		2.0 acres
Josphat Saruni Munguti		2.0 acres

14
10/8



NAME	DESCRIPTION OF PROPERTY	SHARE OF HEIRS
Kesiato Munguti		2.0 acres
Keswe Munguti		2.0 acres
Moonge Munguti		2.0 acres
Koyang Munguti		2.0 acres
Muriithi Mugo		4.0 acres
Moses Ndegwa Gitonga		7.0 acres
Nepruko Siameto Munguti		
Sialo Munguti		
Simon Murunga Ole Munguti		
Longisa Ole Munguti		

To share 16.8 acres

NGONG TOWN PLOT NO. 32

- Hoongipa Munguti ✓
- KESIATO MUNGUTI ✓
- Nepruko Munguti Siameto ✓

To be sold and proceeds shared out equally

Signature.....

JUDGE OF THE HIGH COURT OF KENYA AT NAIROBI

8



REPUBLIC OF KENYA
IN THE HIGH COURT OF KENYA AT NAIROBI
SUCCESSION CAUSE NO. 2395 OF 2003

IN THE MATTER OF THE ESTATE OF SIAMETO OLE MUNGUTI
(DECEASED)

IN CHAMBERS ON THE 20TH DAY OF JULY 2006 BEFORE THE
HONOURABLE MR. JUSTICE DULU.

ORDER

UPON READING the application presented to this court on 24th March, 2006 by counsel for the applicant Under order XLI Rule 4 of the civil procedure Rules sections 3 and 3A of the civil procedure act chapter 21 laws of Kenya AND UPON Reading the affidavit of NEPURKO MUNGUTI SIAMETO sworn on 24th March, 2006 AND UPON reading the replying affidavit of RESIATO MUNGUTI and NOONGIPA MUNGUTI sworn on 28th March 2006 together with annexures thereto AND UPON Hearing counsel for the Applicant and counsel for the Respondent;

IT IS HEREBY ORDERED:-

1. THAT the application be and is hereby struck out.
2. THAT the costs of the application be awarded to the respondents.

GIVEN under my hand and the seal of this court at Nairobi this 20th day of July, 2006

ISSUED at Nairobi this 25th day of July 2008

JD

DEPUTY REGISTRAR
HIGH COURT OF KENYA, NAIROBI

I CERTIFY THIS IS A TRUE COPY OF THE ORIGINAL.

DATE: 25th July 2008

JD

DEPUTY REGISTRAR
HIGH COURT OF KENYA
NAIROBI

P/



20 ~~7~~ 2

REPUBLIC OF KENYA
IN THE COURT OF APPEAL AT NAIROBI
CIVIL APPEAL NO. 272 OF 2002

BETWEEN

NEPRUKO MUNGUTI SIAMETO.....

AND

MICHAEL SIAMETO OLE MUNGUTI.....

HIGH COURT OF KENYA
PROBATE DIVISION
24 NOV 2002
APPELLANT
RESPONDENT

(Appeal from the judgment and order of the High Court of Kenya at Nairobi (Honourable Lady Justice Rawal) dated the 20th day of December 2001 in Succession Cause No.227 of 1980)

MICHAEL SIAMETO OLE MUNGUTI..... APPLICANT

VERSUS

NEPRUKO MUNGUTI SIAMETO..... RESPONDENT

MEMORANDUM OF APPEAL

NEPRUKO MUNGUTI SIAMETO the above-named Appellant appeals to the Court of Appeal against the whole of the above-named decision on the following grounds, namely:-

1. THAT the Learned Judge erred in law and fact in holding that a marriage subsisted between the deceased and Lesiako Munguti (the 1st Claimant).
2. THAT the Learned Judge erred in law and fact in holding that a marriage subsisted between the deceased and Mungipa Munguti (the 2nd Claimant).
3. THAT the Learned Judge erred in law and fact in holding that the children of the 1st and 2nd claimants were children of the Deceased.
4. THAT the Learned Judge erred in law and fact in holding that the Appellant had concealed the fact of the existence of two other married wives and children of the Deceased.
5. THAT the Learned Judge erred in law and fact in holding that Respondent was an 'interested party' under Section 76 of the Law of Succession Act (Cap 160 Laws of Kenya).
6. THAT the Learned Judge erred in law and fact in holding that there was no inordinate delay by the Applicant in bringing this Application.

10

30

50
*



IT is proposed to ask the Court for orders that:-

- (a) This appeal be allowed.
- (b) The judgment of the superior court be set aside and the application dated 21st July 1997 be dismissed.
- (c) Costs of the Appeal and those of the Superior Court be awarded to the Appellant

DATED at Nairobi this 11th day of October 2002.

MOHAMMED & MUIGAI
ADVOCATES FOR THE APPELLANT

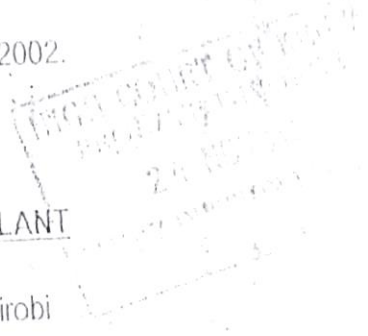

TO: THE Honourable Judges of the Court of Appeal at Nairobi

Copies to be served upon: -

P. K. NJOROGE & CO.
ADVOCATES
JUBILEE INSURANCE EXCHANGE
2ND FLOOR, ROOM 245
P O BOX 34195
NAIROBI

LODGED in the Registry at Nairobi this 14th day of October 2002



DEPUTY REGISTRAR
COURT OF APPEAL AT NAIROBI

DRAWN & FILED BY:
MOHAMMED & MUIGAI
ADVOCATES
HAZINA TOWERS, 10TH FLOOR
MCHUPOVIA STREET
P O BOX 61323
NAIROBI

20

5.



HIGH COURT OF KENYA
PROBATE DIVORCE
11 MAY 2009
FAMILY DIVISION REGISTRY
NAIROBI

REPUBLIC OF KENYA

IN THE HIGH COURT OF KENYA NAIROBI

SUCCESSION CAUSE NO. 2395 OF 2003

IN THE MATTER OF THE ESTATE OF SIAMETO MUNGUTI (DECEASED)

AND

IN THE MATTER OF LAND PARCEL KNOWN AS LR. NO. NGONG TOWNSHIP/32

AFFIDAVIT OF PROTEST

We, RESIATO MUNGUTI and NOONGIPA MUNGUTI residing at and of Post Office Box number 55 Narok make oath and state as follows:-

1. THAT we are the first and second Administrators herein.
2. THAT the affidavit of SIMON OLE MUNGUTI sworn on 8th May, 2009 has been read over to us.
3. THAT we instructed P.K. Njoroge & Co. Advocates to issue instructions to Ellan Traders to sell NGONG TOWNSHIP/32.
4. THAT the Grant herein was issued to us and amended on 8th March, 2006 to include Nepruko. A true copy is annexed hereto and marked "RM-1".
5. THAT the estate had already been distributed on 26th September, 2005. A true copy of the Certificate of Confirmation of Grant is annexed hereto and marked "RM-2".
6. THAT after the death of Nepruko, she was substituted by the applicant and he is now a third administrator. This was by consent on 19th November, 2008.
7. THAT Simon contradicts himself when he says that no representation has been issued since one cannot apply to revoke a Grant that does not exist.

55



8. THAT paragraphs 2,4,5 and 8 of his affidavit are true.
9. THAT it is also true that the initial Grant issued to Nepruko i.e. Simon's mother was revoked on 21st December, 2001 but in a twist of fate:-
- a) **LR. NO. NGONG/NGONG/27** is still in the hands of the protestor and in contempt of this court, he continues to subdivide and sell the same. A true copy of the chart showing the subdivisions is annexed hereto and marked "RM-3".
 - b) That the Land Registrar, Kajiado refused to revert the subject land back to the deceased estate prompting this court to summon him. A true copy of the summons are annexed hereto and marked "RM-4".
 - c) That the court's efforts have been stifled with numerous applications from Nepruko beginning with a one of 8.3.2006, then 9.3.2006, then stay on 24.3.2006.
 - d) That since July, 2006 the file has shifted from Judge to Judge breaking continuity with the result that the pending application have stayed put.
 - e) That the inability on the part court to reign on Nepruko emboldened her to act with impunity;
 - i) On 11th January, 2006, she had the Senior Resident Magistrates Court, Milimani authorize the sale of the deceased's estate. A true copy of the application and the order are annexed hereto and marked "RM-5".
 - ii) on 5th June, 2006, she had Patrick Simiren Munguti a beneficiary charged with trespass, which case is still pending. A true copy of the charge sheet is annexed hereto and marked "RM-6".

53



- iii) That she refused to surrender the revoked Grant. A true copy of the order of this court is annexed hereto and marked "RM-7".
- iv) That the said Grant was produced on 5th May, 2009 in Kibera Court and is now lying before Mr. Karanja as a exhibit.
- v) That we have drawn the attention of the Attorney General to the likely abuse of the process of the court. A true copy of his acknowledgement is annexed hereto and marked "RM-8".
- vi) That even before Mr. Karanja (SRM), the Land Registrar, Kajiado who had been summoned by court was thrown in jail for purporting not to have been served.

10. THAT an appeal to the Court of Appeal does not stay execution of the orders of this court. 272 of 2002

11. THAT we are perfectly in order to seek to dispose off NGONG TOWNSHIP/32.

12. THAT we have been advised by our advocates D.B. Wati & Co. Advocates, which advise we verily believe to be true, that this Honourable Court has inherent powers to protect the property of the deceased for the benefit of all the beneficiaries and not to allow the third administrator to act with impunity.

13. THAT Simon has appropriated the rents from NGONG TOWNSHIP/32 and it is our intention that he should not partake in the proceeds of the sale.

14. THAT this application is therefore scandalous and an abuse of the process of this court.

54



28 .



EYA

Grant of Letters of Administration Intestate

P. & A. 41



REPUBLIC OF KENYA

IN THE HIGH COURT OF KENYA AT NAIROBI SUCCESSION CAUSE NO. H.C./RMX 2395 of 20.03 In the matter of the Estate of SIAMETO OLE MUNGUTI Deceased.

BE IT KNOWN that on the 21ST JULY, 20.04 letters of Administration intestate of all the estate of SIAMETO OLE MUNGUTI (also known as SIAMETO OLE MUNGUTI ALIAS SIAMETO MUNGITI) deceased late of NGONG IN KENYA THE REPUBLIC OF KENYA who died domiciled in on the 29TH OCTOBER 1974 at KAJIADO which by law devolves to and vests in his/her personal representative were granted by this Court to RESIATO MUNGUTI ALIAS RESIATO ENE MUNGUTI, NOONGIPA MUNGUTI ALIAS KAGUINI SIAMETO MUNGUTI and NEPRUKO SIAMETO MUNGUTI of P.O. BOX 55, NAROK he/they having undertaken faithfully to administer such estate according to law and to render a just and true account thereof whenever required by law so to do.

ISSUED by the High Court/Resident Magistrate's Court through the registry at NAIROBI IN KENYA this 21ST JULY, 20.04

AMENDED AT NAIROBI THIS 8TH DAY OF MARCH 2006.

Signature [Handwritten Signature]

Judge of the High Court/ Resident Magistrate

This is the exhibit marked RM-112 Referred to in the annexed affidavit of Resiata & Nepruko Sworn before me this 11th May 2009 Day of Nairobi Commissioner for

52



EX 2

FORM P&A 54



This is the exhibit marked "Rm-2"
Referred to in the affidavit of
RESIATO & NOONGIPA
Sworn before me this 17th
day of May 2009
[Signature]
COMMISSIONER OF LANDS

REPUBLIC OF KENYA
IN THE HIGH COURT OF KENYA AT NAIROBI
SUCCESSION CAUSE NO. ...2395 of 2003

IN THE MATTER OF THE ESTATE OF ...SIAMETO OLE MUNGUTI..... (DECEASED)

CERTIFICATE OF CONFIRMATION OF GRANT

I HEREBY certify that the above written grant of representation to the estate of the late
.....SIAMETO OLE MUNGUTI..... issued to
.....RESIATO MUNGUTI & NOONGIPA MUNGUTI.....
. therein named has this26TH SEPTEMBER 2005..... been confirmed by the
Court pursuant to the provisions of section 71 of the Law of Succession Act.

Dated at Nairobi this ..26TH DAY OF SEPTEMBER 2005

SCHEDULE

<u>Name</u>	<u>Description of Property</u>	<u>Share of Heirs</u>
	L. R. NO. NGONG/NGONG/27	
Noongipa Munguti		2.0 acres
Patrick Simiren Munguti		2,0 acres
Michael Sironka Munguti		2.0 acres
Kennedy Parsimei Munguti		2.0 acres
Benson Lemeria Munguti		2.0 acres
Samuel Kuseo Munguti		2.0 acres
Josphat Saruni Munguti		2.0 acres



NAME	DESCRIPTION OF PROPERTY	SHARE OF HEIRS
Resiatio Munguti		2.0 acres
Keswe Munguti		2.0 acres
Moonge Munguti		2.0 acres
Koyang Munguti		2.0 acres
Muriithi Mugo		4.0 acres
Moses Ndegwa Gitonga		7.9 acres

Nepruko Siameto Munguti
 Sialo Munguti To share 16.8 acres
 Simon Murunga Ole Munguti
 Longisa Ole Munguti

NGONG TOWN PLOT NO. 32

Noongipa Munguti
 RESIATO MUNGUTI To be sold and proceeds shared out equally
 Nepruko Munguti Siameto

Signature.....

JUDGE OF THE HIGH COURT OF KENYA AT NAIROBI



KAJADO/NGONG/NGONG /27 -ILLEGAL SUBDIVISIONS

27

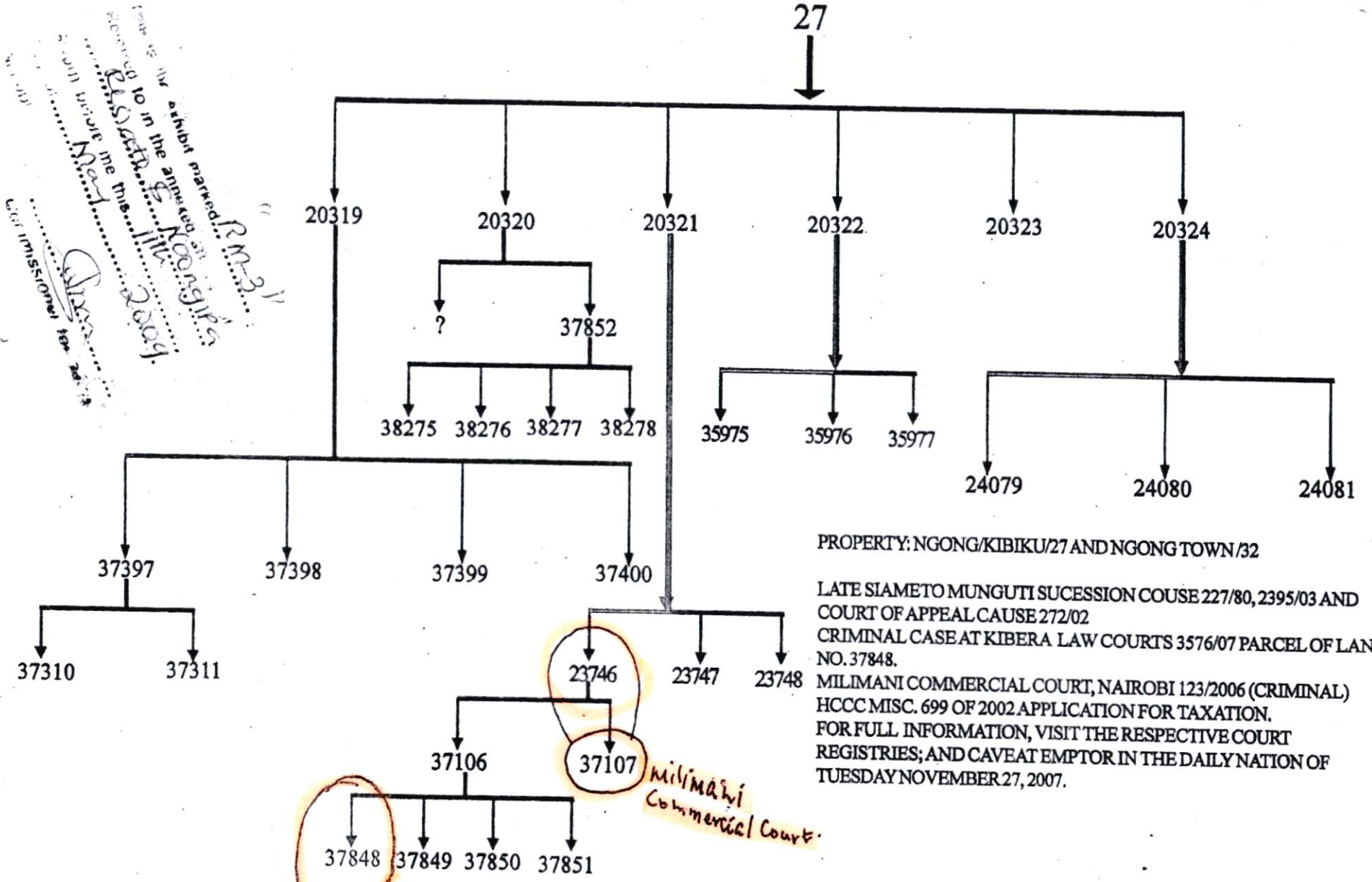

PROPERTY: NGONG/KIBIKU/27 AND NGONG TOWN/32

LATE SIAMETO MUNGUTI SUCCESSION COUSE 227/80, 2395/03 AND COURT OF APPEAL CAUSE 272/02

CRIMINAL CASE AT KIBERA LAW COURTS 3576/07 PARCEL OF LAND NO. 37848.

MILIMANI COMMERCIAL COURT, NAIROBI 123/2006 (CRIMINAL) HCCC MISC. 699 OF 2002 APPLICATION FOR TAXATION.

FOR FULL INFORMATION, VISIT THE RESPECTIVE COURT REGISTRIES; AND CAVEAT EMPTOR IN THE DAILY NATION OF TUESDAY NOVEMBER 27, 2007.

Milimani Commercial Court

Please see the exhibit marked R.M.31
 attached to in the application
 submitted to the Registrar
 of the High Court of Kenya
 Nairobi. I will ensure the
 same is done.

Commissioner for Lands
 Nairobi

OCS Ngong to see - Kibera Court 3576/2007

29

25



30
~~18~~



Law Society of Kenya

Patrick Simiren Munguti
P O Box 32097
NAIROBI

Lavington, opp Valley Arcade, Gitanga Road
P.O. Box 72219-00200 Nairobi, Kenya
Dropping Zone 149 - Revlon Plaza
Tel: +254 20 387 4664
Cell: +254 720 904983
Fax: +254 20 387 5534
E-mail: lsk@lsk.or.ke
Website: www.lsk.or.ke

Our Ref: M3

Your Ref: 3.6.08

Date:

Dear Sir,

RE: COMPLAINT AGAINST SENIOR RESIDENT MAGISTRATE E. C. CHERONO

Thank you for your letter dated 26/5/08.

On the face of your letter a Senior Resident Magistrate cannot revoke the orders of the High Court or Court of Appeal.

We advise that we do not have jurisdiction over magistrates. Please lodge **your complaint with the Chief Justice.**

Yours faithfully,

**ADDRAYA E. DENA
COMPLIANCE & ETHICS
(PROGRAM DIRECTORS)**

Okong'o Omogeni (chairman), J. A. Mwamu (vice chairman),
I. J. M. Wamaasa (up-country representative), M. I. Buluma (up-country representative),
Joseph Munyithya (Coast representative), E. N. Monari, K. W. Akide
F. Mwangangi, F. Kajuju, G. O. Ochich, L. R. Omondi, E. J. L. Aukot

30

1



Witness

REPUBLIC OF KENYA

IN THE HIGH COURT

AT NAIROBI

SUC. CAUSE NO 2395 (V. S. H.) OF 20.03
IN THE MATTER OF THE ESTATE OF SIAMETC MUNGU

.....	}	Plaintiff
.....		
	}	Defendant
.....		

against

To: **THE LAND REGISTRAR**
KAJIADO LANDS REGISTRY
KAJIADO

WHEREAS your attendance is required to **PRODUCE DOCUMENTS** on behalf of the **1ST AND 2ND ADMINISTRATORS** above suit, you are hereby required (personally) to appear before this Court on the **23RD** day of **MARCH**, 20**10** at **9.00** o'clock in the forenoon, and to bring with you (or to send to this Court) and so from day to day until your presence is dispensed with by the Court, produce **official searches certified copies of the Green Cards mutation forms, application to subdivide consent and nearest index maps for all subdivisions and resultant subdivisions NGONG/NGONG/27**.
 A sum of Shillings **1000/-** being your travelling and other expenses and subsistence allowance for one day is herewith sent. If you fail to comply with this order without lawful excuse, you will be subject to the consequences of non attendance laid down in rule 12 of Order XV of the Civil Procedure (Revised) Rules 1948.

Given under my hand and the Seal of the Court this day of 20**10**

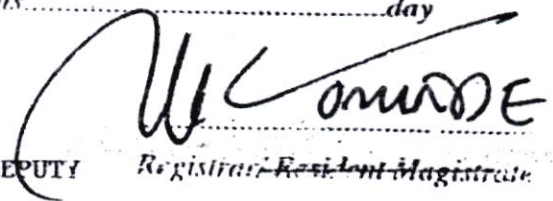
 DEPUTY Registrar-Resident Magistrate

- NOTE:— (1) If you are summoned only to produce a document and not to give evidence, you shall be deemed to have complied with the summons if you cause such document to be produced in this Court on the day and hour aforesaid.
- (2) If you are detained beyond the day aforesaid a sum of Shillings..... will be tendered to you for each day's attendance beyond the day specified.

13



Summons to Witness.

CIVIL 16 A

REPUBLIC OF KENYA

IN THE HIGH COURT OF KENYA
AT NAIROBI
SUCCESSION CAUSE NO. 2395 OF 2003

THIS IS THE EXHIBIT MARKED NM-81
ANNEXED TO THE AFFIDAVIT OF DECLARATION
OF Nepurko Munguti Siameto
SWORN BEFORE ME THIS 21ST DAY OF
November 2006 AT Nairobi
COMMISSIONER OF COURTS

IN THE MATTER OF THE ESTATE OF SIAMETO OLE MUNGUTI

To: NEPURKO MUNGUTI SIAMETO
NGONG

WHEREAS your attendance is required to GIVE EVIDENCE AND PRODUCE RECORDS on behalf of the ADMINISTRATORS in the above suit, you are hereby required (personally) to appear before this Court on the 8TH day of February 2006 at 9.00 o'clock in the afternoon, and to bring with you (or to send to this court) and so from day to day until your presence is dispensed with by the Court TO GIVE EVIDENCE ON YOUR DEALINGS ON NGONG/NGONG/ 27

A sum of Shillings 500/= being your travelling and other expenses and subsistence allowance for one day is herewith sent. If you fail to comply with this order without lawful excuse, you will be subject to the consequences of non-attendance laid down in rule 12 of Order XV of the civil Procedure (Revised) Rules 1948.

Given under my hand and the Seal of the Court this 6th day of February 2006

[Signature]
Registrar/ Resident Magistrate

- NOTE: (1) If you are summoned only to produce a document and not to give evidence, you shall be deemed to have complied with the summons if you cause such document to be produced in this court on the day and hour aforesaid.
- (2) If you are detained beyond the day aforesaid a sum of shillings..... will be tendered to you for each day's attendance beyond the day specified

32.



15/04/2002

P.B. 26/04/2002 - 15/04/2002 Reg - 1,000/-
9/14/2002

REPUBLIC OF KENYA
IN THE HIGH COURT OF KENYA AT NAIROBI

SUCCESSION CAUSE NO. 227 OF 1980
IN THE MATTER OF THE ESTATE OF SIAMETO OLE MUNGUTI
(DECEASED)

MICHAEL SIRONKA MUNGUTI APPLICANT

-VERSUS-

TEKLA NYABURURU MUNGUTI RESPONDENT

IN CHAMBERS ON 21ST DECEMBER 2001
BEFORE HONOURABLE LADY JUSTICE RAWAL (MRS)

ORDER

APPLICATION FOR ORDERS;

1. THAT service of application dated 24th July 1997 be dispensed with in the first instance.
2. THAT an injunction order be issued to restrain NEPRUKO MUNGUTI, SIAMETO the Administrator of the Estate of SIAMETO OLE MUNGUTI, from wasting, damaging alienating, sub-dividing, selling or disposing or in any other way howsoever disturb all that property known as NGONG/NGONG/ now sub-divided to Ngong/Ngong/20319, 20320, 20321, 20322, 20323, 20324, 20744, 20747, 20748 until the hearing and determination of this application or further orders of the Court.
3. THAT the letters of Administration granted to NEPRUKO MUNGUTI SIAMETO on 9th December 1980 be revoked on the following grounds, inter alias:-
 - (i) The grant was obtained fraudulently by the Administrator, in making false statement that she was the only widow and her children as the only children of the late SIAMETO OLE MUNGUTI.
 - (ii) The grant was obtained fraudulently by the Administrator who concealed from the Court the fact that the said Deceased was a polygamist, with three wives, the Administrator included, and Eighteen children.
 - (iii) The Administrator has failed to produce to Court within the time presented, such inventory or such account of administration of the Estate of the said Deceased.

REGISTRAR



(iv) THAT costs be provided for.

THIS SUIT COMING for hearing on 31st day of October of 2001 and for submissions on 19th November 2001 and for judgement on 21st December 2001 before Honourable lady Justice Rawal (Mrs) in the presence of Counsel for the Petitioner and Counsel for the Respondent.

IT IS HERBY ORDERED:-

1. THAT the grant of letters of Administration issued to Nepruko Munguti Siameto (whose name was unceremoniously changed to Tekla Nyambururu Munguti) be and is hereby revoked
2. THAT a fresh petition be filed with the three widows under the provision of the Law of Succession Act.
3. THAT the Administrator do pay the costs of the proceedings.

GIVEN UNDER my Hand and the Seal of this Court the 21st day of December 2001.

ISSUED this day of 2002.

Handwritten signature
SENIOR DEPUTY REGISTRAR
HIGH COURT OF KENYA
NAIROBI

I CERTIFY THIS IS TRUE COPY OF THE ORIGINAL.
 DATED: *23rd March 2002*

 DEPUTY REGISTRAR
 HIGH COURT OF KENYA
 NAIROBI

REGISTERED THIS 16TH AUGUST 2002

Handwritten signature
LAND REGISTRAR

34



FRESH PETITION 3295 of 2003..

35
9

P. K. NJOROGE & COMPANY
ADVOCATES & COMMISSIONERS FOR OATHS

P. K NJOROGE LL. B. (Hons) NBI. DIP. LAW (KSI)

P.O. Box 49658
Nairobi, Kenya
Tel: 225193/220160
Fax: 244763
Email: penka@insightkenya.com

Hand Deliveries:
Jubilee Insurance Exchange
2nd Floor, Room 245 & 246
Mama Ngina Street

Our ref: PKN 708/00

Date: 23rd February 2004

Your ref:

The Land Registrar
Kajiado Land Registry
KAJIADO

Dear Sir,

RE: (a) NGONG/NGONG/20319
(b) NGONG/NGONG/20320
(c) NGONG/NGONG/20321
(d) NGONG/NGONG/20322
(e) NGONG/NGONG/20323
(f) NGONG/NGONG/20324
(g) NGONG/NGONG/23746
(h) NGONG/NGONG/23747
(i) NGONG/NGONG/23748

Plot No. 32 Ngong Town - 8
K.N.
24/2/04

Please refer to the above Land Parcels which have records in your registry. The land parcel No. Ngong/Ngong/27 belonged to one Siameto Ole Munguti who died interstate survived by 3 widows.

The youngest of the widows filed **Succession Case No.227 of 1980** at the High Court of Nairobi alone. However her grant was revoked on the **20th December 2001.**

We have evidence that she had sub-divided the land and transferred to Third Parties and her children. But with the grant revoked she has no say in the estate until she obtains another grant.

It is quite interesting and unbelievable that your office has always refused to register the Order revoking the grant against all the titles and state that "no dealings should be entertained on all the parcels until the Succession Cause No. 227 of 1980 is concluded and shares of heirs determined.

Please register the relevant Orders to preserve the sub-stratuni and status quo ante of the deceased properties.

22.



We shall then move the Court to delete the names of the people unlawfully registered.

Yours faithfully,



P. K. NJOROGE

CC: 1. Clients

2. The District Commissioner
Kajiado District.

Received on
25/04/04
DISTRICT COMMISSIONER
KAJIADO

22



EDITION: 1

PART A - PROPERTY SECTION

OPENED: 4.09.97
REGISTRATION SECTION

EASEMENTS ETC.

NATURE OF TITLE

NGONG/NGONG

PARCEL NUMBER

29319

APPROXIMATE AREA

6.35

HA

REGISTRY MAP SHEET No.

8/SE & 13N1

ADD VISION OF NO.27

PART B - P.O. MORTGAGE SECTION

ENTRY No.

DATE

NAME OF REGISTRAR

ADVERSE PARTITION OF REGISTERED PROPERTY

4.09.91

MUNGO MORTGAGE BANKING

Box 75 NGONG HILLS.

2.4.94

THE TRUSTEES

187-1-0-1

8.2.3079

CAUTION BY MORTGAGEE

187-1-0-1

INTEREST

4.2.1998

CAUTION BY MORTGAGEE

187-1-0-1

5.2.1998

CAUTION BY MORTGAGEE

187-1-0-1

6.7.1998

CAUTION BY MORTGAGEE

187-1-0-1

7.20.1.2000

CAUTION BY MORTGAGEE

187-1-0-1

TITLE NUMBER

NGONG/NGONG

20319

Electronic
Registry System
21337-611
THIS LINE

Confirmed true copy
Ngong 23/5/03
Ngong 025

PART A - PROPERTY SECTION

EDITION: 1

OPENED: 2, 09, 2007

REGISTRATION SECTION

EASEMENTS ETC.

NATURE OF TITLE

NGONG/NGONG

PARCEL NUMBER

20320

APPROXIMATE AREA

0.25

Ha

REGISTRY MAP SHEET

8/2007 15/100

START TIME OF REGISTRY

PART B - PROPRIETORSHIP SECTION

ENTRY No.	DATE	NAME OF REGISTERED PROPRIETOR	ADDRESS AND DESCRIPTION OF REGISTERED PROPRIETOR	CONSERVATOR AND REMARKS	STATUS OF ENTRY
1	14/09/97	MURPHU WONG IS SIANG	203 203 203 H.T.S.		
2	14/09/97	LETTO SANG	203 203 203 H.T.S.		
3	14/09/97	LETTO SANG	203 203 203 H.T.S.		
4	14/09/97	LETTO SANG	203 203 203 H.T.S.		
5	27/10/99	SIMON OIE MANSUT	151031543		
6	27/10/99	NGONG DEED			
7	20/11/2007	Restriction and dealing to be registered with application at the court			

TITLE NUMBER

NGONG NGONG

20320

Cont'd of time copy of 20315103

E PLANNING
ANALYSIS SYSTEM
21337-511
TITLE BELOW
THIS LINE

Kalimzoo
Business Systems
21337-611
* THIS LINE
TITLE BELOW

PART A - PROPERTY SECTION		PART B - PRIORSHIP SECTION	
EDITION:	1	NAME OF REGISTERED PROPRIETOR	DATE
OPENED:	4.09.97	REPUBKO MONDRII SLEPMO	14.09.97
REGISTRATION SECTION	NGONG/NGONG	ADDRESS AND DISTRICT OF REGISTERED PROPRIETOR	3275 NGONG
REGISTRY MAP SHEET NO.	8/SB & 13/NE	CONSIDERATION AND REASONS	
APPROXIMATE AREA	3.36 Ha	SIGNATURE OF REGISTRAR	
PARCEL NUMBER		PART B - PRIORSHIP SECTION	
20321		REGISTRATION SECTION	
		NATURE OF TITLE	
		ABSOLUTE	

NO.	DATE	NAME OF REGISTERED PROPRIETOR	ADDRESS AND DISTRICT OF REGISTERED PROPRIETOR	CONSIDERATION AND REASONS	SIGNATURE OF REGISTRAR
1	4.09.97	REPUBKO MONDRII SLEPMO	3275 NGONG		
2	4.09.97	Titic	15 NO 10308/bv	ISERD	
3	3.3.99	Carion 37 MICHOLS SINGH - MUNDRI	41-P.O BOX 03, NGONG (LAWYER'S OFFICE)		
4	24.9.99	INTEREST			
5	24.9.99	Parcel in 23746	Parcel in 23746		
6	24.9.99	Titic Closed and Sub-Division	Parcel in 23746 - 23748		

TITLE NUMBER

REGISTRATION SECTION
NGONG/NGONG

PARCEL NO.
20321

Copyright true copy
23/5/03
21337-611

32

Illegible text at the top of the page, possibly a header or title.

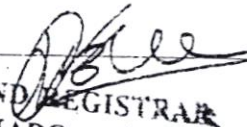

40

EDITION: 1		PART A - PROPERTY SECTION	
OPENED: 24.9.99			
REGISTRATION SECTION		EASEMENTS ETC	
REGISTRATION SECTION		<p>C.T.C</p>  <p>DISTRICT LAND REGISTRAR KUALA</p>	
PARCEL NUMBER			
23746			
APPROXIMATE AREA			
3.06 Ha.			
REGISTRY MAP SHEET No.		NATURE OF TITLE	
		ABSOLUTE	

SUBDIVISION OF NO. 20321 PART B - PROPRIETORSHIP SECTION

ENTRY No	DATE	NAME OF REGISTERED PROPRIETOR	ADDRESS AND DESCRIPTION OF REGISTERED PROPRIETOR	CONSIDERATION AND REMARKS	SIGNATURE OF REGISTRAR
1	24.9.99	NAPURKO MUNGUTI SIAMETO			
2	24.9.99	THE DEED		ISSUED.	
3	24.9.99	CAUTION BY MICHAEL SILVANO MUNGUTI TO BOY			<p>Entries Signed</p>
		23 NAROK CLAIMING BENEFICIARY INTEREST			
4	27.10.99	CAUTION ENTRY THREE ABOVE REMOVED UNDER SECT 133 2(B).			
5	20.1.2000	no dealing to be registered until application at the court of appeal is determined			
6	9.10.2000	RESTRICTION ENTRY NO 5 ABOVE REMOVED AS PER FILED AFFIDAVIT.			

Kalamazoo
11337 41
TITLE BELOW THIS LINE



CONTINUATION PART II

NAGONG/NAGONG

PARCEL NUMBER
23746

C.T.C

ABSOLUTE

REGISTRY MAP SHEET NO.

DISTRICT LAND REGISTRAR

PART B - PROPRIETORSHIP SECTION

NO.	DATE	NAME OF REGISTERED PROPRIETOR	DECEASED ESTATE OF REGISTERED PROPRIETOR	CONSIDERATION AND REMARKS	SIGNATURE OF REGISTRAR
7	30.8.04	COURT ORDER NO DEALINGS UNTIL SUCCESSION			
-	-	CAUSE NO. 227 OF 1980 IS FINALISED AT HIGH COURT OF (K) NB 1			
8	3.2.06	CORRECTION ORDER NB. 7 ABOVE REMOVED UNDER CIVIL SUIT CASE NO. 123 OF 2006 DATED 29.1.06			
9	3.2.06	TITLE ELONGED ON SUBDIVISION SEE NEW NOS 37106 & 37107			

Entries signed



42

EDITION: 1		PART A - PROPERTY SECTION			
OPENED: 3.2.06					
REGISTRATION SECTION NGONG/NGONG	EASEMENTS ETC.		ABSOLUTE		
PARCEL NUMBER 37107	<i>C.T.C.</i>				
APPROXIMATE AREA 0.13 Ha.	<i>None</i>				
REGISTRY MAP SHEET NO. 8 SE & 13 NE	DIREKTOR JALAN REGISTRAR KAMPUNG				
SUBDIVISION OF NO. 23746		PART B - PROPRIETORSHIP SECTION			
ENTRY NO.	DATE	NAME OF REGISTERED PROPRIETOR		ADDRESS AND DESCRIPTION OF REGISTERED PROPRIETOR	CONSIDERATION AND REMARKS
1	3.2.06	NEPURKO MUNGUTI SIAMETO ID/1063283	BOX 75, NGONG	D. K. ...	Entricks Signet
2	3.2.06	KENNEDY DORA ONDIEKI	ID/8772608	180000	
3	3.2.06	TITLE DEED BOX 21158 MRI			

41486

TITLE BELOW

54



43

EDITION: 1		PART A - PROPERTY SECTION	
OPENED: 21.9.99			
REGISTRATION SECTION	EASEMENTS ETC		NATURE OF TITLE
TONGA/TONGA			ABSOLUTE
PARCEL NUMBER	C.T.C		
23747			
APPROXIMATE AREA			
0.2025 Ha.			
REGISTRY MAP SHEET No.	DISTRICT LAND OFFICER KAIAMAZOO		

SUBDIVISION OF NO. 20321		PART B - PROPRIETORSHIP SECTION			
ENTRY No	DATE	NAME OF REGISTERED PROPRIETOR	ADDRESS AND DESCRIPTION OF REGISTERED PROPRIETOR	CONSIDERATION AND TERMS	SIGNATURE OF REGISTER
1	24.9.99	NAPURKO MUNGUTI SIAMETO			<i>Entirely Signed</i>
2	24.9.99	MURIAH WAMBANO	ID 18762750		
3	24.9.99	TITLE DEED		ISSUED.	
4	20.5.2003	ATHMAN SALIM MOHAMMED	ID/11143381		
5	20.5.2003	TITLE DEED		ISSUED	
6	30.5.04	COURT ORDER NO DEALINGS UNTIL SUCCESSION CAUSE NO. 227 OF 1980 AT HIGH COURT OF NBI (FINAL?)			

Kaiamazoo
21337-511
TITLE BELOW THIS LINE

TITLE NUMBER	REGISTRATION SECTION	PARCEL No
	TONGA/TONGA	23747

43





PART A - PROPERTY SECTION

EDITION:	1		
OPENED:	14.09.97		
REGISTRATION SECTION		EASEMENTS ETC.	NATURE OF TITLE
	WONG/NGONG		
PARCEL NUMBER			
	20322		
APPROXIMATE AREA			ABSOLUTE
	1.32 Ha		
REGISTRY MAP SHEET No.			
	8/52 & 13/NE		

SUBDIVISION OF NO. 27

PART B - PROPRIETORSHIP SECTION

INSTR. No.	DATE	NAME OF REGISTERED PROPRIETOR	ADDRESS AND DESCRIPTION OF REGISTERED PROPERTY	CONSTITUTION AND EXTENTIVE	REGISTERED IN
14.09.97		WONG HING SHUN	8075 NGONG HING		
24.9.97		Decd	12nd subject to	WONG	
3.3.99		CAUTION BY MORTGAGE	SHAWA MORTGAGE		
		WONG HING SHUN	12th subject to	WONG	
27.10.98		WONG HING SHUN	12th subject to	WONG	
5.10.98		WONG HING SHUN	12th subject to	WONG	
1.27.10.98		WONG HING SHUN	12th subject to	WONG	
7.10.98		WONG HING SHUN	12th subject to	WONG	

TITLE NUMBER

NGONG/NGONG

20322

Confid time copy
of original land register

Wong Hing Shun
25/5/03

Electronic
Registration
2337-611
TITLE BELOW
THIS LINE *

5

5

EDITION: 1
OPENED: 4.09.97
PART A - PROPERTY SECTION

REGISTRATION SECTION
EASEMENTS ETC.
NATURE OF TITLE

INGONG/INGONG

PARCEL NUMBER
20323

APPROXIMATE AREA
1.1
ABSOLUTE

REGISTRY MAP SHEET NO.
8 35 & 12/NE

PART B - PARTNERSHIP SECTION

ENTRY NO.	DATE	NAME OF REGISTERED PROPRIETOR	ADDRESS AND DESCRIPTION OF REGISTERED PROPERTY	CONTRIBUTION AND REM. PART	SIGNATURE OF REGISTERED PROPRIETOR
1409		RETIRED MUMUKU BANDA	FOR 1/2 SHARE		
2000		T. I. I. C.	2000 12/11/2000	100%	
2001		2001 03/03/2001	2001 03/03/2001	100%	
2002		2002 03/03/2002	2002 03/03/2002	100%	
2003		2003 03/03/2003	2003 03/03/2003	100%	
2004		2004 03/03/2004	2004 03/03/2004	100%	
2005		2005 03/03/2005	2005 03/03/2005	100%	
2006		2006 03/03/2006	2006 03/03/2006	100%	
2007		2007 03/03/2007	2007 03/03/2007	100%	
2008		2008 03/03/2008	2008 03/03/2008	100%	
2009		2009 03/03/2009	2009 03/03/2009	100%	
2010		2010 03/03/2010	2010 03/03/2010	100%	
2011		2011 03/03/2011	2011 03/03/2011	100%	
2012		2012 03/03/2012	2012 03/03/2012	100%	
2013		2013 03/03/2013	2013 03/03/2013	100%	
2014		2014 03/03/2014	2014 03/03/2014	100%	
2015		2015 03/03/2015	2015 03/03/2015	100%	
2016		2016 03/03/2016	2016 03/03/2016	100%	
2017		2017 03/03/2017	2017 03/03/2017	100%	
2018		2018 03/03/2018	2018 03/03/2018	100%	
2019		2019 03/03/2019	2019 03/03/2019	100%	
2020		2020 03/03/2020	2020 03/03/2020	100%	
2021		2021 03/03/2021	2021 03/03/2021	100%	
2022		2022 03/03/2022	2022 03/03/2022	100%	
2023		2023 03/03/2023	2023 03/03/2023	100%	

TITLE NUMBER

INGONG/INGONG

20323

REGISTRY MAP SHEET NO. 8 35 & 12/NE

REGISTRATION SECTION

REGISTRATION SECTION

REGISTRATION SECTION

REGISTRATION SECTION

Centred true copy

23/5/03

B. M. Ngany

Ngany B. M.

EDITION: 1
 OPENED: 4.09.97
 REGISTRATION SECTION

PART A - PROPERTY SECTION

NATURE OF TITLE

REGISTRATION SECTION

NGONG/NGONG

PARCEL NUMBER
20324

APPROXIMATE AREA

1.1 Ha.

REGISTRY MAP SHEET NO.

8 / SE & 13 / NE

PART B - PROPRIETORSHIP SECTION

ENTRY NO.	DATE	NAME OF REGISTERED PROPRIETOR	ADDRESS AND DESCRIPTION OF REGISTERED PROPRIETOR	CONSIDERATION AND REMARKS	SIGNATURE OF REGISTRAR
1	4.09.97	MEPURKO MUMUPTI SIAMENO	Box 75 NGONG HILLS.		
2	4.09.97	Title	Decd 12 ND 1663263/188 RD		
3	3.3.99	Proprietor by MURTHIEL SINDIKA MUMUPTI	OF P.O BOX 23, NAROK (LAWMURU)		
4	27.10.99	Consent entry under sec. 132(2)	Consent entry under sec. 132(2)		
5	27.10.99	Consent entry under sec. 132(2)	Consent entry under sec. 132(2)		
6	27.10.99	Consent entry under sec. 132(2)	Consent entry under sec. 132(2)		
7	27.10.99	Consent entry under sec. 132(2)	Consent entry under sec. 132(2)		
8	25.12.99	Proprietor - NO dealing should be accepted as per application for registration	Proprietor - NO dealing should be accepted as per application for registration		

TITLE NUMBER

20324

Kolamazo
 21337-611
 TITLE BELOW
 THIS LINE

17



REPUBLIC OF KENYA
IN THE CHIEF MAGISTRATES COURT AT NAIROBI
MILIMANI COMMERCIAL COURTS
CIVIL SUIT NO. 123 OF 2006

KENNEDY OBARA ONDIEKI PLAINTIFF

VERSUS

NEPURKO MUNGUTI SIAMETO DEFENDANT

CERTIFICATE OF URGENCY

I, S. NYABERI an Advocate of the High Court of Kenya do hereby certify this application to be of utmost urgency and ought to be heard as such on the grounds that the Respondent sold the Applicants a piece of parcel of land being NGONG/NGONG 23746 whereas the Respondent had caused it to have restriction registered on the property at the Land Registry Kajiado whilst the Applicant needs to develop the property thus the urgency.

Dated at Nairobi this 11th day of January 2006

[Signature]
OMWOYO, MOMANYI GICHUKI & CO.
ADVOCATES FOR THE APPLICANT

DRAWN AND FILED BY
OMWOYO, MOMANYI GICHUKI & CO.
ADVOCATES
CAMEO BUILDING 1ST FLOOR DOOR 3
BANDA STREET
P.O. BOX 50380-00200
NAIROBI

This is the exhibit marked RM-5
referred to in the annexed affidavit of
Kebate + Nongipa
Sworn before me this 11th day of
May 2006
[Signature]
Commissioner for ...

1st filing
250-App.
150-ord.
30-App.
50st

2130/-



REPUBLIC OF KENYA
IN THE CHIEF MAGISTRATES COURT AT NAIROBI
MILIMANI COMMERCIAL COURTS
CIVIL SUIT NO. _____ OF 2006

KENNEDY OBARA ONDIEKIPLAINTIFF

VERSUS

NEPURKO MUNGUTI SIAMETODEFENDANT

CHAMBER SUMMONS

(Under Order xxxix Rules 1,2 & 9 Civil Procedure Rules Sections 3 and 3A Civil Procedure Act Chapter 21 Laws of Kenya together with all other enabling provisions of Law)

LET ALL PARTIES CONCERNED attend the Honourable Magistrate in chambers on theday of2006 at 9.00 o'clock in the forenoon or so soon thereafter when counsel for the Plaintiff/Applicant shall be heard in an application for **ORDERS: -**

- 1) **THAT** this application be heard exparte at the first instance and it be certified as urgent.
- 2) **THAT** an injunction do issue directing the Defendants to remove a restriction placed by herself at the Kajiado Land Registry in parcel no. **NGONG/NGONG 23746** pending the hearing and final determination of this suit.
- 3) **THAT** costs of this application be provided for.

WHICH APPLICATION is supported by the annexed affidavit **of KENNEDY OBARA ONDIEKI** and on the following grounds: -

- 1. The Applicant bought part of parcel no. **NGONG/NGONG 23746** measuring approximately 0.133 ha. from the Defendant.
- 2. The Defendant/Respondent had earlier placed a restriction on the property.
- 3. The Applicant has obtained all the necessary consents to have the title registered in his name.
- 4. The Respondent has been reluctant to remove the restriction and has been giving excuses and not acting to the promises.

PA



- 5. That unless the Respondent is ordered by this Honorable Court to remove the said restriction, it shall continue pending at the Land Registry Kajiado to the detriment of the Applicant.
- 6. And on such other further grounds that may be adduced at the hearing hereof.

Dated at Nairobi this 11th day of January 2006.



**OMWOYO, MOMANYI GICHUKI & CO.
ADVOCATES FOR THE APPLICANT**

DRAWN AND FILED BY
OMWOYO, MOMANYI GICHUKI & CO.
ADVOCATES
CAMEO BUILDING 1ST FLOOR DOOR 3
BANDA STREET
P.O. BOX 50380-00200
NAIROBI

TO BE SERVED UPON
NEPURKO MUNGUTI SIAMETO
P.O. BOX 75
NGONG HILLS

(If any party served does not appear at the time and place above mentioned such orders shall be given and proceedings taken as the court may deem just and expedient.)



REPUBLIC OF KENYA
IN THE CHIEF MAGISTRATES COURT AT NAIROBI
MILIMANI COMMERCIAL COURTS
CIVIL SUIT NO. _____ OF 2006

KENNEDY OBARA ONDIEKIPLAINTIFF

VERSUS

NEPURKO MUNGUTI SIAMETODEFENDANT

SUPPORTING AFFIDAVIT

I KENNEDY OBARA ONDIEKI of P.O. Box 21153 Nairobi within the Republic of Kenya do hereby solemnly and sincerely swear and state as follows: -

1. **THAT** I am a Kenyan male adult of sound mind and the Applicant herein therefore competent to swear this affidavit.
2. **THAT** during the month of October 2005 I bought a piece of parcel of land being **NGONG/NGONG/23746** from the Defendant at a consideration.
3. **THAT** immediately on purchasing the said portion, I embarked on the process of having surveyors on the ground to do mutations on the property and the same was done by the surveyor that I had employed to do the job. (Annexed and marked **KOO-1** are copies of mutation forms and survey deed).
4. **THAT** the said piece of parcel of land was to be hived off from **NGONG/NGONG/23746** and I was to get a portion thereof measuring approximately 0.133 ha.
5. **THAT** I made necessary applications to the Land Control Board Kajiado for consent to transfer the portion I bought from the Defendant into my names (Annexed and marked **KOO-2** is a copy of the said application).
6. **THAT** at its meeting held on the 1st November 2005 the Land Control Board, Oloolaiser gave its consent to have the 0.133ha to be hived from the Respondents portion being **NGONG/NGONG 23746**. (Annexed and marked **KOO-3** is a copy of the said consent)
7. **THAT** on lodging all the relevant documents with the Land Registrar Kajiado to effect the said transfer of the portion into my name, the Registrar bluntly told me that the same was not to take place as the Respondent had placed a restriction on the land (Annexed and marked **KOO-4** is a copy of the green card indicating restriction).
8. **THAT** I have made several attempts to have the Respondent remove the said restriction, but she had been giving excuses that she will remove the same but those excuses have not borne any fruits therefore the present application.

out order

Handwritten mark resembling a stylized '7' or a bracket pointing to item 7.



- 9. THAT I swear this affidavit in support of my herein annexed application to have orders directing the Respondent to remove the restriction so that I proceed with the registration of the property into my name.
- 10. THAT if the said restriction is not removed I shall be made to suffer irredeemably having paid the respondent fully of the consideration and her not giving me possession of the property that I paid for.
- 11. THAT what is deponed to herein above is true to the best of my knowledge information and belief,

Sworn by the Said
KENNEDY OBARA ONDIEKI
 At Nairobi This 11th Day of January 2006
 BEFORE ME

} 
 }
 }
 }
 }
 }
 }
 }
 }
 }
 }



COMMISSIONER FOR OATHS

DRAWN BY
OMWOYO, MOMANYI GICHUKI & CO.
ADVOCATES
CAMEO BUILDING 1ST FLOOR DOOR 3
BANDA STREET
P.O. BOX 50380-00200
NAIROBI



Date received for registration
15/11/2005

Presentation Book No. 305162

53
Registration Fees Shs 27300
Paid Receipt No. Cons 250
Date 9/11/2005
Date 11/11/05

Survey Fees: Shs.....

Receipt No.....

R.I.M Amendment Fee; Shs. 240K

Receipt No. 0273937

Form R.L. 29

REPUBLIC OF KENYA

THE REGISTERED LAND ACT, 1963

MUTATION FORM

(This form is to be completed in triplicate)

[Signature]
11/11/05

[Signature]

Title No. NGONG/NGONG/23746 this is the exhibit marked KOO-1A

Approximate Area 3.06 referred to in the affidavit declaration. Hectares.

Registry Map Sheet No. 8/SE 2 13/NE of Kennedy Obura Ondreki sworn

Registered Proprietors' Instructions to the Surveyor 11th day of January

1. Present boundaries of parcel are shown on the sketch on page 20 at NAIROBI in Kenya

- (a) (i) The proprietor wishes to subdivide the parcel as shown by the dotted lines on the sketch before me
or
Commissioner for Oaths
Notary Public
- (ii) The proprietors wish to change their common boundary as shown by dotted lines on the sketch.
or
- (iii) The proprietors wish to partition the parcel as shown by the dotted lines on the sketch.
or
- (iv) The proprietor wishes to combine his parcels as shown by the brace on the sketch.

(b) The new parcel numbers will be:
relevant approximate area

A	B						
37106	37102						
2.93	0.13						

(c) The relevant Letter or Consent to subdivide/partition the parcel is attached. X

(d) The persons interested, and their addresses are:
NEPURKO MUNGUJI SIAMETO
10/ND 1063 283
P.O BOX 75,
NGONG HILLS.

They will meet the Surveyor at.....
on at a.m/p.m. or on the land at a time appointed by him.

(e) Please advise the Land Registrar when the mutation is surveyed and Registry Index Map amended.

22



FIELD DIAGRAM AND OBSERVATIONS ON SITE

To be completed by the Surveyor
(Attach a tracing to scale where appropriate)

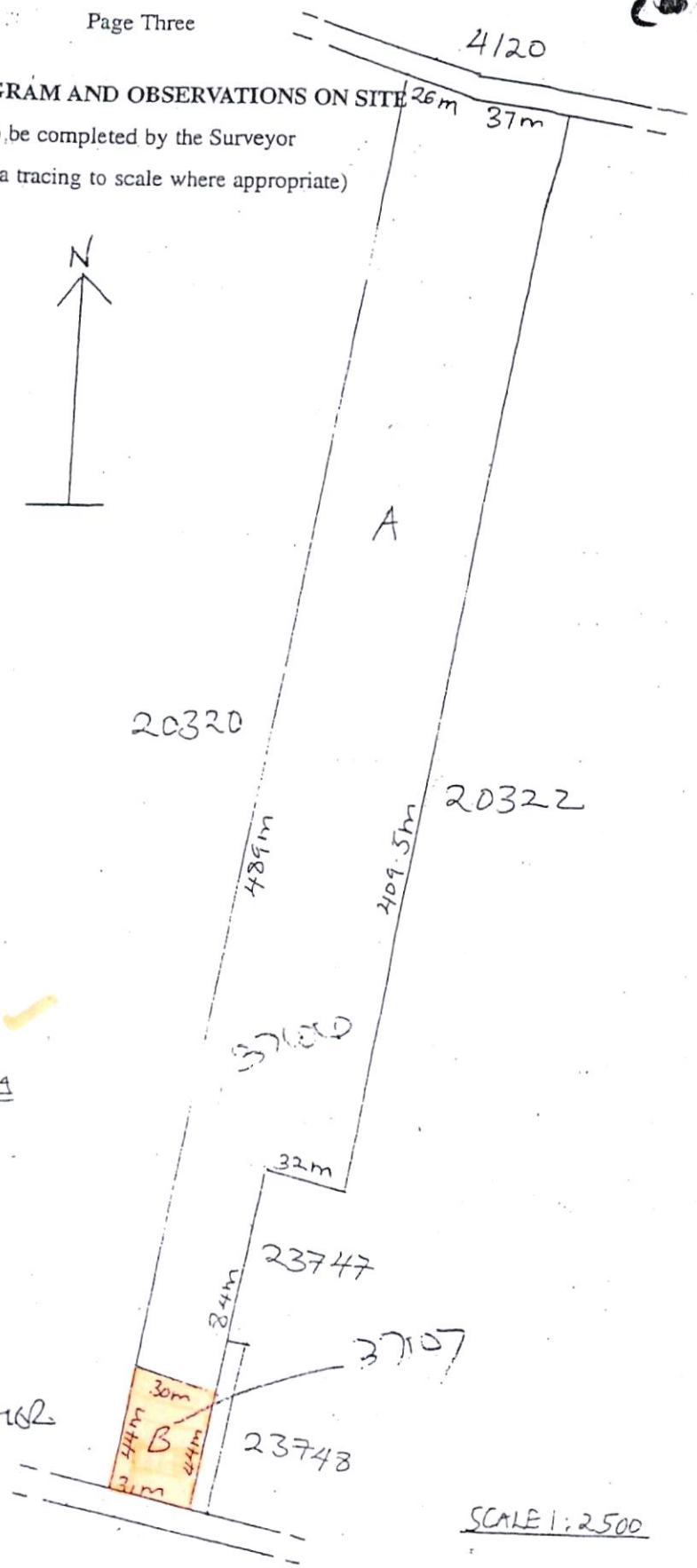

AREAS

A ≈ 2.93 HA

B ≈ 0.13 HA

TOTAL ≈ 3.06 HA

I CERTIFY THAT THE WORK PERFORMED IN THE FIELD & IN THE OFFICE BY MY ASSISTANT MR. W.O. RATHOR HAS BEEN CARRIED OUT UNDER MY PERSONAL DIRECTION & I TAKE FULL RESPONSIBILITY OF THE WORK SO PERFORMED.

SIGNED _____

This is to certify that this field sketch contains the actual figures recorded by me at the time of observation and measurements in the field.

Certificate under Schedule 9 of the Survey Regulations to be provided in case the survey has been done by an Approved Assistant.

Date 6/11/2005

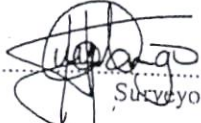
Surveyor

SCALE 1:2500

24



55 NOV

This is the exhibit marked _____
referred to in the _____ affidavit
_____ declaration FORM 1

REPUBLIC OF KENYA
of Kennedy Obara Ondieki
THE LAND CONTROL ACT
(Cap. 302) _____ day of January _____
at NAIROBI in Kenya

APPLICATION FOR CONSENT OF LAND CONTROL BOARD

To be submitted in TRIPPLICATE in respect of each transaction and sent to or left at the appropriate office of the Commissioner of Lands

Commissioner of Lands
Notary Public

To: THE _____
LAND CONTROL BOARD.

L.C.R. No. 90/1/2005

I HEREBY apply to the OLOLAISER
Land Control Board for its consent to the transaction described below, and give the following information:

1. (a) Present registered holder of interest (full name in BLOCK LETTERS):
NEPURKO MUNGUTI SIAMEFO
ID/NO 1063233

(b) Nationality KENYAN
(c) Address P.O. BOX 75, NGUNGU HILLS

2. (a) Proposed purchaser, transferee, mortgagee, chargee, allottee, etc. (full name in BLOCK LETTERS) KENNEDY OBARA ONDIEKI
ID/NO 3772603

(b) If a limited liability company, names of directors, authorized and issued share capital and principal shareholders; if a co-operative society, names of chairman, secretary and treasurer and total number of members—
N/A

(c) Nationality KENYAN Certificate No. _____
(d) Address P.O. BOX 21158, NRB

3. Nature of transaction (e.g. sale, gift, lease, mortgage, charge, etc.: if sale or allotment of shares name of company, number and particulars of shares to be transferred)
TRANSFER

4. Term (i.e. the length of time for which the land affected is to be transferred or leased if sale or allotment of shares, authorized share capital of the company and numbers of shares issued at date of application)

5. Description of Land—
L.R. or Parcel No. NGONG/NGONG/
Area 0.133 ITA
Locality NGONG
County Council OLKARIA A



ORIGINAL (Registrar's Copy)

This is the exhibit marked

referred to in the

Form 2(A)

declaration

of Kennedy Obara Ondieki
sworn

REPUBLIC OF KENYA

this 11th No. 99973 day of January

2006 at NAIROBI in Kenya

THE LAND CONTROL REGULATIONS, 1968

The Registrar Land Control Board Oath
P.O. Box 78 Notary Public

To: Nepurko Munyuti Seareto Ngong Hills

Date 14 November 2005

Reg. No.

L.C.R. No. 9014/2005

SIR/MADAM,

LETTER OF CONSENT

1. With reference to your application dated the 14th November 2005 the Board gave its consent to the following controlled transaction at its Monthly meeting held on the 1st November, 2005

2. Nature of Transaction:

(a) L.R. or Parcel No. Ngong Ngong

(b) Locality

(c) Sale, lease, subdivision, mortgage, charge, etc. TRANSFER of 0.133HA

(d) Names of parties

(i) from Nepurko Munyuti Seareto

(ii) to Kennedy Obara Ondieki

(e) Length of term

(f) Consideration

3. Special conditions of approval of subdivision:

- (a)
(b)
(c)
(d)
(e)

I am, Sir/Madam, Your obedient servant

Chairman Land Control Board

Copy to:

The Commissioner of Lands, Nairobi.
The Central Agricultural Board.

2



This is the exhibit marked 57 50 referred to in the affidavit declaration of Kennedy Obara Ombite this 11th day of January

at NAIROBI in Kenya
 EDITION 1
 OPENED 24.9.99
 REGISTRATION SECTION
 MONG/MONG
 PARCEL NUMBER 23746
 APPROXIMATE AREA 3.06
 REGISTRY MAP SHEET No. Ha.

SUBDIVISION OF NO. 20321

PART B - PROPRIETORSHIP SECTION

PART A - PROPERTY SECTION
 EASEMENTS ETC.

ABSOLUTE

ENTRY No.	DATE	NAME OF REGISTERED PROPRIETOR	ADDRESS AND DESCRIPTION OF REGISTERED PROPRIETOR	CONSIDERATION AND REMARKS	SIGNATURE OF REGISTERED PROPRIETOR
1	24.9.99	MATTHEO MUNGUTI SIAMETO			
2	24.9.99	MATTHEO MUNGUTI SIAMETO			
3	24.9.99	MATTHEO MUNGUTI SIAMETO			
4	27.10.99	MATTHEO MUNGUTI SIAMETO			
5	20.1.2000	MATTHEO MUNGUTI SIAMETO			

Date 27/1/2000
 Signature [Signature]
 Director Land Registrar

at the court of appeal is determined
 registration of the above is determined
 SECTION 23(2)

REGISTRATION SECTION

PARCEL No. 23746

KALAMAZOO
 21337-611
 TITLE BELOW
 THIS LINE

01/12



CONTINUATION PART II

22009/22009

PARCEL NUMBER 23746	C. T. C.	ABSOLUTE
APPROXIMATE AREA		
REGISTRY MAP SHEET NO.		
DISTRICT LAND REGISTRAR		

PART B - PROPRIETORSHIP SECTION

DATE	NAME OF REGISTERED PROPRIETOR	REGISTERED INTEREST OR REGISTERED BURDEN	CONSERVATION AND REMARKS	SIGNATURE OF REGISTRAR
7	30.80.04	COURT ORDER NO DEALINGS UNTIL SUCCESSION CAUSE NO. 227 OF 1980 IS FINALIZED AT HIGH COURT OF (K) NB 1		<i>Entrils signed</i>
8	3.2.06	COURT ORDER SURRY NO. 7 ABOVE REMOVED UNDER CIVIL SUIT CASE NO. 123 OF 2004		
9	3.2.06	DATED 29.1.06 TITLE DELETED ON SUBDIVISION SEE NEW NOS 37106 & 37107		



IN THE CHIEF MAGISTRATE'S COURT AT NAIROBI
(MILIMANI COMMERCIAL COURTS)

CIVIL CASE NO. 123 OF 2006

KENNEDY OBARA ONDIEKI PLAINTIFF
VRS
NEPUKO MUNGUTI SIAMETO DEFENDANT

ORDER

UPON RREADING the application presented to this court on the 11th day of January, 2006 by the advocate for the plaintiff/applicant and supported by the affidavit of KENNEDY OBARA ONDIEKI herein sworn on the same day.
AND WHEREAS the application coming for interpartes hearing on the 20th day of January, 2006 before E.C. CHERONO (Mr) Senior Resident Magistrate in the presence of counsel for the plaintiff/applicant and in the presence of the counsel for the respondent.

AND UPON HEARING the said counsel,

IT IS ORDERED BY CONSENT

1. THAT the application dated 11th January, 2006 be and is hereby allowed and restrictions placed on parcel No; **NGONG/NGONG 23746** be removed.
 2. THAT this order also do apply on **parcel Nos; NGONG/NGONG 20319, 20320, 20322, 20323 and 30324.**
4. THAT the District Land Registrar be served with orders herein for compliance.
THAT costs be in the cause.

GIVEN UNDER my hand and seal of this court on the 20th day of January, 2006



E.C. CHERONO (ESQ)
SENIOR RESIDENT MAGISTRATE

ISSUED at Nairobi this 20th day of January, 2006

SENIOR RESIDENT MAGISTRATE

۲۲



Accused informed of charge, searched and placed in cell by.....			
Prisoners' Property Book No.....	
Bail Book No.....	
Fingerprints taken by.....	
Fingerprints to Bureau	
Fingerprints from Bureau	
Completed certificate of previous convictions to Bureau ..			
First information and Progress Report to Commissioner of Police	
Final Report to Commissioner of Police	
Charge Register completed and case closed	
HOLLERITH STATS. 1	
HOLLERITH STATS. 2	
HOLLERITH STATS. 3	
HOLLERITH STATS. 4	

2. ANTECEDENTS OF ACCUSED (as known to Investigating Officer).

II. TRESX TRESPASS WITH INTENT TO ANNOY CONTRARY TO SECTION 5(1)(a) OF THE TRESPASS ACT CAP 294 LAWS OF KENYA.

3. BRIEF CIRCUMSTANCES OF CASE (Evidence of Arrest, etc.) (For use in Summary P.C.R. Offences only):—

PATRICK SIMILEN MUGUTI. On the 2nd day of June 2007 at Kibiko 'B' in Kajiado within Rift Valley Province, trespassed in the farm of ELIZABETH SIALO MUNGUTI NGONG/NGONG/38312 with intent to annoy her by planting tress and fencing without her consent.

POLICE 5

THE KENYA POLICE
CHARGE SHEET

POLICE CASE No. PCR 804 / 07

O.B. No. 35/2/6/07.

DATE TO COURT 5/6/07.

COURT FILE No. 3587/0

Christian Names in full or Name PATRICK SIMILEN	Surname or Father's Name MUGUTI	Identity Certificate No.	Sex M M	Nationality or Tribe KAAS	Apparent Age A	ADDRESS (include District and Location where applicable) C/O NAROK DISTRICT MOI DEBI LOCATION.
---	---	--------------------------	-------------------	-------------------------------------	--------------------------	--

CHARGE
PM

COUNT I

TRESPASS WITH INTENT TO ANNOY CONTRARY TO SECTION 5(1)(a) OF THE TRESPASS ACT CAP 294 LAWS OF KENYA. ³⁽¹⁾

PARTICULARS OF OFFENCE (See Second Schedule of C.P.C.)

PATRICK SIMILEN MUGUTI. On the 2nd day of June 2007 at Kibiko reserve in Kajiado District of the Rift Valley Province, trespassed the farm of of NEPURKO MUGUTI SIAMETO NGONG/NGONG/37848 with intent to annoy her by fencing the farm and planting trees without her consent.

If Accused Arrested	Date of Arrest	Without or with Warrant	Date Apprehension Report to Court	Bond or Bail and Amount	Is Application made for Summons to Issue
YES	2/6/07	W/O	6/6/07	? ON CASH BAIL 50000	//////////

Remanded or Adjourned to

Complainant and Address

NEPURKO MUGUTI AND ELIZABETH SIAMETO NGONG OF KIBIKO

Witnesses ...	1. NEPURKO MUGUTI	6
	2. ELIZABETH SIAMETO	7
	3. STANLEY KENANA	8
	4. GUSTAF NGONG	9
	5.	10

Sentence

Court and date "M-6" 5/6/07. If fine paid

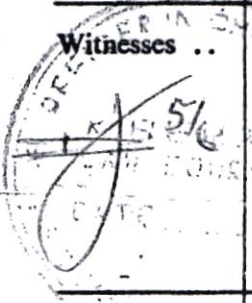

This is the exhibit marked "M-6" referred to in the annexed affidavit of Kenani & Ngong sworn before me this 11th day of May 2007 at Narok

Officer in Charge [Signature] Police Station

[P.T.O.]

10(b) 61

Telegrams: "SHARIFA", Nairobi
Telephone: Nairobi 227461
When replying please quote



ATTORNEY-GENERAL'S CHAMBERS
P.O. Box 40112-00100
NAIROBI, KENYA

Ref. No.
AG/CR/ 2014/2943

28th October, 2008

10(b)

DCI
Criminal Investigation Headquarters
NAIROBI.

RE: **KIBERA SRM CRC NO 3576/07**
REPUBLIC VERSUS PATRICK SIMEREN MUNGUTI

We make reference to your letter dated 25th June, 2008 and ours dated 11th July, 2008. Kindly note that the correct file number **KIBERA SRM CRC NO 3576/07** and not **KIBERA SRM CRC NO 2576/07** as earlier indicated by the complainant.

Kindly but urgently forward the police file for our perusal and directions.

LILIAN OBUO
STATE COUNSEL
FOR: ATTORNEY GENERAL

Cc: **NOONGIPA MUNGUTI**
P.O.BOX 32097-00600
NAIROBI.

- We acknowledge the receipt of your letter dated 22/8/08 forwarding the correct criminal case number. We shall revert to you once we peruse the police file accordingly.

.



25



63

EDITION: 1		PART A - PROPERTY SECTION	
OPENED: 1.8.06			
REGISTRATION SECTION NGONG/NGONG	EASEMENTS ETC.		ABSOLUTE
PARCEL NUMBER	C.T.C.		
37819	<i>Blue</i>		
APPROXIMATE AREA			
0.20 Ha.			
REGISTRY MAP SHEET NO.	8 SE & 13 NE		

SUBDIVISION OF NO. 37106		PART B - PROPRIETORSHIP SECTION			
ENTRY NO.	DATE	NAME OF REGISTERED PROPRIETOR	ADDRESS AND DESCRIPTION OF REGISTERED PROPRIETOR	CONSIDERATION AND REMARKS	SIGNATURE OF REGISTRAR
1	1.8.06	NEPURKO MUNGUTI SIAMETO	BOX 75, NGONG		
2	1.8.06	TITLE DEED		ISSUED	<i>Entries signed</i>
3	5.9.07	GRACE WANGUI NGATIA IN/10112534		250,000/- SHS	
4	5.9.07	TITLE DEED		ISSUED	
TITLE NUMBER		REGISTRATION SECTION NGONG/NGONG		PARCEL NO. 37819	

11.000
DATE EXPIRES
THIS YEAR

23

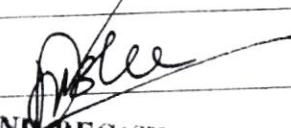

EDITION: 1	PART A - PROPRITY SECTION	
OPENED: 1.8.06		
REGISTRATION SECTION NGONG/NGONG	EASEMENTS ETC.	NATURE OF TITLE
PARCEL NUMBER 37850	 DISTRICT LAND REGISTRAR KAJIADO	ABSOLUTE
APPROXIMATE AREA 0.40 Ha.		
REGISTRY MAP SHEET NO. 8 SR & 13 NE		

SUBDIVISION OF NO. 37106		PART B - PROPRIETORSHIP SECTION			
ENTRY NO.	DATE	NAME OF REGISTERED PROPRIETOR	ADDRESS AND DESCRIPTION OF REGISTERED PROPRIETOR	CONSIDERATION AND REMARKS	SIGNATURE OF REGISTRAR
1	1.8.06	MURKUNO MUNGUTI SIAMETO	BOX 75, NGONG		
2	1.8.06	TITLE DEED			
2	2.8.06	EVANS MALAVA WERESA ID/10163054 ALICE MUNAH AYODI ID/8740743			
3	2.8.06	TITLE DEED BPA 75 NGONG HILLS		ISSUED	
4	16.9.09	TITLE CLOSED ON SUBMISSION NOW SEE NEW NOS: 48975-48977			

Entries
Signed

11486

TITLE NO. 37850

TITLE NUMBER

REGISTRATION SECTION
NGONG/NGONG

PARCEL NO.
37850

42

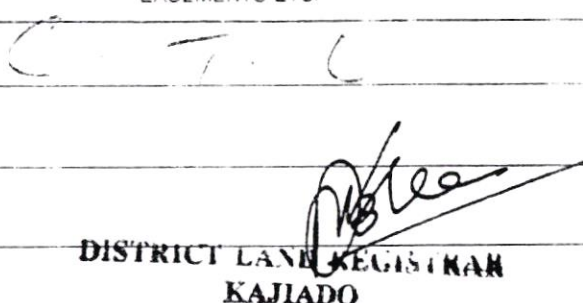
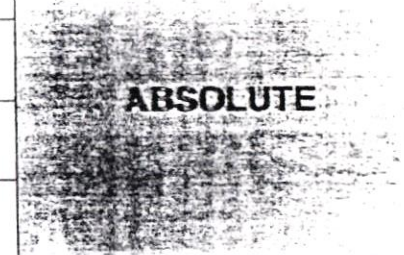

59

EDITION: 1	PART A - PROPERTY SECTION	
OPENED 16.9.09		
REGISTRATION SECTION	EASEMENTS ETC	NATURE OF TITLE
NGONG/NGONG		
PARCEL NUMBER		
46975		
APPROXIMATE AREA		
0.24 Ha.		
REGISTRY MAP SHEET No.	DISTRICT LAND REGISTRAR KAJIADO	
8/SE & 13/NE		

subdiv of No. 37850

PART B - PROPRIETORSHIP SECTION

ENTRY No	DATE	NAME OF REGISTERED PROPRIETOR	ADDRESS AND DESCRIPTION OF REGISTERED PROPRIETOR	CONSERVATION AND REMARKS	SIGNATURE OF REGISTRAR
1	16.9.09	EVANS MALAYA WEKESA	10/1016 3050	} 54M	
		ALICE MUNAI AYODI	10/87407.43		
2	16.9.09	TITLE DEED	Box 75 NGONG HILLS	ISSUED	

Kalamazoo A30225414

TITLE BELOW THIS LINE

TITLE NUMBER

REGISTRATION SECTION

NGONG

REGISTRATION

20





REPUBLIC OF KENYA

THE REGISTERED LAND ACT
(Chapter 300)

Title Deed

Title Number NGONG/NGONG/37848

Approximate Area 2.18 HA.

Registry Map Sheet No. B 53 C 13 UB

This is to certify that REPUKKO MUNGUPI SIAMETO ID/1063283

is (are) now registered as the absolute proprietor(s) of the land comprised in the above-mentioned title, subject to the entries in the register relating to the land and to such of the overriding interests set out in section 30 of the Registered Land Act as may for the time being subsist and affect the land.

GIVEN under my hand and the seal of the

KAJIADO District Land Registry

this 1ST day of AUGUST, 2006

Land Registrar

22

GICHONE

0727996897



REPUBLIC OF KENYA

REGISTRATION PAGE

DEPOSIT RECEIPT

B 460455

Spmo Kibera

RECEIVED from Nancy Njeri Mwiria

5/6/07

the sum of Shillings Twenty thousand only

being payment into Court in Criminal Case No. 3576/07

Parties: Acc: -

Patrick Simken Mwangi

20,000/-

Hq: 20/6/07

Court 4

Signature of Receiving Officer



21



68

17

521

12

CAVEAT EMPTOR

SUCCESSION OF THE LATE SIAMETO MUNGUTI:-
KAJIADO/NGONG/ NGONGI 27 AND SHOP ON PLOT NO.32 AT NGONG TOWN CENTRE
HIGH COURT OF KENYA, NAIROBI 227/80, 2395/2003, MILIMANI COMMERCIAL COURT NAIROBI
123/2006, KIBERA SENIOR RESIDENT MAGISTRATE COURT NO.3576/2007 (CRIMINAL) AND
COURT OF APPEAL 272/2002

The above cases are ongoing in respective law courts. No dealings with the whole or any part of the above properties before all cases are determined and concluded. Any title of a parcel of land purporting to originate from subdivision of Kajiado/Ngong/Ngong /27 is fake and therefore is of no value to any holder, financial institutions included. Dont bother to verify title with official search at Kajiado Land Registry or Ololaisir Land Control Board at Ngong.

The current status of the above can be verified by a search at the High Court of Kenya, Nairobi, Family Division registry or P.K Njoroge and Company Advocates, Jubilee Insurance Exchange, 4th Floor, Room 409 C and 410 Mama Ngina Street. P.O. Box 49658-00100, Nairobi.

Trespassers with fake titles to be prosecuted and developments to be demolished and land returned to its original status in accordance with environment laws at trespassers cost

IGNORANCE WILL NOT BE A DEFENCE

APPLAUD AFRICA
Uganda most...
Kanu Heart Foundation...
Goodies for Christmas...
Business in Africa...
November 2007

Sept/Dec Issue

UGANDA MOST EXCLUSIVE WEDDING PLUS:

KANU HEART FOUNDATION PREPARES TO LAUNCH IN EAST.AFRICA

Now available throughout East Africa and in all Nakumatt Supermarkets, leading book stores and vendors near you.
For subscription contact:
Sonia on Tel: 3288586/74
Email: sgakuru@nation.co.ke

ANTIQUE AUCTIONS Ltd.
R. W. Maina
P.O. Box 32229- 00600,
Tel: 3748451, Tel/Fax: 3750419 Nairobi
Mobile: 0722-705027.
Email: rowama2003@yahoo.com

Blessed House 2nd Floor Door No. 5, Ngara Road, Ngara Estate, Opp. Ngara Post Office.

PUBLIC AUCTION

Duly instructed by our principles the chargees, we shall sell by public auction the undermentioned property together with all the improvements erected thereon.

AGRICULTURAL PROPERTIES IN THIKA DISTRICT

TO BE SOLD ON FRIDAY 14TH DECEMBER 2007 AT 11.00 AM AT THIKA TOWN NEAR THE POST OFFICE
Parcel Nos. LOC 16/KIGORO/305, 960 AND 958 belonging to David Ngugi Kamau GT John Ngunjiri Ngugi.

NOTE: (i) Property 305 is freehold measuring about 4.2 acres situated off Gatanga-Ndakaini road in Kigoro sub-location about 100m to the east of Njuni Tea Factory in Thika District. Elected thereon are 3-bedroom house, various temporary structures and poultry house. About 1.5 acres are under tea bush and the rest under subsistence farming.
(ii) Property 960 is freehold measuring about 3.43 acres situated a few hundred metres to the west of Njuni tea factory. It is under mature tea bush.
(iii) Property 958 is freehold measuring about 0.222 of an acre situated next to property (ii) above and vacant.

CONDITION OF SALE

- All interested purchasers are requested to view property and verify all the details, as these are not warranted by the auctioneer.
- A deposit of 25% must be paid at the fall of the hammer and the balance within 30 days to the chargees.
- Sale of the property is subject to the reserve price.

WAGLY AUCTIONEERS
Auctioneers, Court Brokers, Court Bailiffs, Commission Agents and Repossessors (Licensed Class "B")

Head Office:
8th Floor, Posta Sacco Plaza
Junction Uhuru Highway, University way
P.O. Box 7031 - 00300 Nairobi
Tel: 254-020 311536, 225543 Fax: 2113003 Nairobi

Branch Office
1st Floor, Equator House
Opp. S. S. Cinema, Kenyatta Lane
P.O. Box 1622: Tel: 211645 / 6
Fax: 054 - 037 45357, Nakuru

PUBLIC AUCTION

Duly instructed by our Principals we shall sell the following goods by public auction on Tuesday 4th December 2007 at Leakey's Storage Lunga Lunga road, Starting from 11.00 a.m.

DISTRESS FOR RENT - LANDLORD -VS- (TENANTS) (A) PETER MURGOR (B) MR. MESHACK (C) GISHION TRADING LTD (D) BILL BOSMAN (E) ANEZ MUTANU MWEDWA (F) CHARLES ODAWA

(A) Ramton Iron box, electric kettle, DVB Machine, 5 Assorted widow curtains, 2Pcs sofa set & Puff, Computer stand, T.V. Trolley and others (B) 3Pcs six seater sofa set, LG Colour T.V with remote, T.V. Cabinet, LG DVD with remote, Mobil gas cylinder, One burner gas cooker and others (C) 2 Metallic chairs, 2 office desks; one metallic arm chair, one wooden chair (D) Sony Colour T.V., Orwa radio cassette, Toshiba Colour T.V, LG DVD with remote, LG one door Small fridge, 2 burner gas cooker, 5pcs seven seater sofa set, coffee table (E) Ricoh Photocopy Machine, Computer set, Sony 3CD charger with remote, Sony Colour T.V with remote, LG DVD with remote, Hitachi VCR with remote, Sony CD player music system with remote (F) 29" Colour T.V. with remote, Samsung Colour T.V. with remote, LG DVD with remote, Kenwood Music System, 45 Assorted chairs, 17 Assorted tables, 2 big external speakers, 8 empty crates of beer, 6 crates with beer,

CONDITIONS OF SALE
Strictly CASH at the fall of the Hammer.
ALL ARE WELCOME

Oct - Dec issue now in stores

GOODIES for Christmas Diwali & Idd

Available at all Nakumatt outlets and selected bookshops and convenience stores
For subscription contact:
Sonia on 3288586/92 or
sgakuru@nation.co.ke

Business in Africa November 2007

INTERRUPTION OF ELECTRICITY SUPPLY

Notice is hereby given under rule 27 of the Electric Power Rules that the electricity supply will be interrupted as here under:

AREA: ONGATA RONGAI, MAGADI RD
Ongata Rongai, Laiser Hill Acad, Maasai Lodge, Gataka Rd, Nazarene Versity, KCCT Mbagathi, Banda Sch, Kitembe Est, Avocado Lane & adjacent customers.
DATE: Thursday 29.11.07 TIME: 0900 - 1700HRS

AREA: MUHAKA
Mwabungo, Mtsangatifu, ICPE & adjacent customers.
DATE: Tuesday 27.11.07 TIME: 0900 - 1700HRS

20

.





Noongipa Munguti
P.O Box 32097-00600
Nairobi

4/5/2008

MA 2015.208 - Judiciary

The Attorney General
State Law Office
Nairobi (attention: - DPP)

1. (SRM chero no of Milimani Commercial Court: - can his orders override high court & court of appeal caution on land)
2. (Kajiado District Land Registrars: - Nyantika, Lukoko and Nkuruna, clerk to Oloolaiser land control board;- Can they be allowed to use a SRM's order to remove a High Court caution on land when the cases are ongoing)
3. (OCS, Ngong police station and prosecutor at Kibera law courts: - under what circumstances are they intervening in Munguti family inheritance civil dispute)
4. (Kajiado District Commissioner: - A registered letter of complaint by Patrick Simiren Munguti (see Kibera SRM 2576/2007)
5. (Caveat Emptor: - see Daily Nation 27th November 2007)



The Chief Justice Evan Gicheru
Law Courts
Nairobi

1. (SRM Chero no of Milimani Commercial Court: - Can his orders override High Court & Court of Appeal caution on land)
2. (Kajiado District Land Registrars: - Nyantika, Lukoko and clerk Nkuruna of Oloolaiser land control board- Can they be allowed to use a SRM's order to remove a High Court caution on land when the cases are ongoing)
3. (OCS, Ngong police station and prosecutor at Kibera law courts- under what circumstances are they intervening in Munguti family inheritance civil dispute)

The Chairman
Law Society of Kenya
Nairobi

1. (Mr. Chero no of Milimani Commercial Court, Nairobi to be investigated in regard to 123/2006 for incompetent interrogation of the case).
Photocopies of Green cards and Chero no's court order attached

Dear Sirs,

SUCCESSION OF THE LATE SIAMETO MUNGUTI (35 YEARS) DIED 35 YEARS AGO

EXECUTIVE SUMMARY

1. Clan dispute resolution mechanism
2. Chief's summons meeting
3. Kajiado SRM court No. 4 of 1996
4. Succession Cause 227/80
5. Succession - Court of Appeal 272/2002
6. Succession Cause No.2395/2003 (confirmation of grant)
7. Milimani Commercial Court (SRM) 123/of 2006
8. Criminal (trespass) case at SRM Kibera Court 2576 of 2007
9. Succession Cause 2395 of 2003 (application for police protection for implementation)
10. Kajiado District Commissioner- Letter of complaint by Simiren Munguti
11. Caveat Emptor: - daily Nation 27th November 2007

90



A CRY FOR HELP IN JUSTICE DELAYED AT VERY HIGH COST (SIMPLE CASE TURNS COMPLEX)

To an ordinary Kenyan, succession cases are the simplest to handle. It mostly involves members of a family and unless there are quarrels the event should not take more than a year. Understandable extension of time beyond a year can occur when there is complicity of liabilities. But the following sad history of a case raises many questions about effectiveness and efficiency of judiciary.

HISTORY AND ISSUES

1. LATE SIAMETO OLE MUNGUTI

The late Siameto Munguti died intestate in 1974 leaving three widows and more than twenty children. That is 35 years to date. Cows and other personal items were shared out in accordance with the Masai traditions. The rest was left intact with an understanding letters of administration will be sought when all wives are past menopause.

However, in 1980, the sly Nepruko Munguti outsmarted the other two and obtained letters of administration cause 227/80 alone thus disinheriting the other two widows, Noongipa Munguti, Resiatio Munguti and their eighteen children. Unlike the other two, Nepruko was not married to Siameto ole Munguti in the traditional Masai wedding nor a church one. She joined Munguti at Ngong after unceremoniously breaking her Masai traditional marriage and running away from Ole Kerore who is the father of her daughter Sialo. Noongipa and Resiatio accepted her as a co-wife after she gave birth to two sons while living with Munguti Siameto

2. FAMILY DISPUTE RESOLUTION

Immediately the two widows found out what happened, they tried family dispute resolution using the clan elders' forum. This did not work as expected as Nepruko showed contempt and did not attend any of the elders sitting.

3. CHIEF'S OFFICE AT NGONG

The dispute was taken to the chief of Ngong in 1996. Nepruko attended once and missed the second appearance. This prompted the then chief Wilson Turito to refer the issue to the Kajiado District Land Tribunal since this issue revolves around two parcels of land namely Ngong/Ngong/27 and shop on plot 32 Ngong

40



4. KIAJIADO LAND TRIBUNAL

Conclusion was that Munguti's 50.0 acres property be shared equally that is 16.87 acres each and plot number 32 in Ngong Town be sold and the proceed shared equally between the three widows. Nepruko did not attend and the case was referred to the Senior Resident Magistrate Court at Kajiado town for determination.

The minutes of the tribunal was circulated to
Mrs Resiato Munguti
Mrs Noongipa Munguti
Mrs Nepruko Munguti
Land Registrar- Kajiado
Magistrate Court - Kajiado
District Commissioner - Kajiado Chairman, Oololaiser land Control Board

5. KAJIADO SENIOR RESIDENT MAGESTRATE COURT: - CIVIL SUIT NO.4 OF 1997

The case proceeded to the Kajiado District magistrate's court as No.4 of 1997. The respondent Nepruko Munguti, did not show up. This prompted the then Senior Resident Magistrate H.N Ndungu (Miss) to come to the same conclusion as the land tribunal that the parcel of land Ngong/Ngong/27 be shared equally amongst the three widows.

6. (I) HIGH COURT AT NAIROBI 227/80

A complaint against Nepruko Munguti was launched to revoke the letters of administration issued to her in 1980. Noongipa Munguti and Resiato Munguti successfully challenged 227/80 and judgment was made in their favour by Judge Kaplana Rawal in 2001. *A court order revoking the grant 227/80 to Nepruko was made and a fresh petition was to be made with the three widows under the provisions of the law of succession commenced. That the Administrator named in 227/80 pays the cost of the proceedings.*

This court order put an injunction against wasting, damaging, sub-dividing, selling or disposing or in any other way what so ever disturb the property known as NGONG/NGONG/27, until the hearing and determination of this application or further orders of the court

(II) HIGH COURT AT NAIROBI 227/80 (REVISED ORDER)

The Kajiado District Land Registrar refused to register the court order as he had refused to recognize the Tribunal's decision. Reason being that NGONG/NGONG/27 did not exist since it had illegally been subdivided in 1997 while the dispute was going on various courts as seen above.

11



ILLEGAL SUBDIVISION OF NGONG/NGONG/27

The parcel of land was subdivided 1997 and resultant titles issued to Nepruko and another person. The illegal subdivision was for part sale to finance the Siameto Munguti succession war. The Tribunal was sitting for this from 7th November through to 27th January 1997 and ended 24th September 1996. The parcel of land NGONG/NGONG/27 could not therefore go through normal subdivision process in September 1999. Reason being members of the TRIBUNAL are also members of the OLOOLAISER LAND CONTROL BOARD. It was subject to the ILLEGAL GRANT OF CONSENT TO SUBDIVIDE AND TRANSFER, POPULARLY KNOWN AS SPECIAL LAND CONTROL BOARD. It is therefore not surprising the land registrar is impervious to orders from the tribunal and the High Court and Court of Appeal to cancel the subdivision to revert to NGONG/NGONG/27

The court order was amended to include all the parcels of land that originated from the illegal subdivision of NGONG/NGONG/27. And they are Ngong/Ngong/20319, 20320, 20321, 20322, 20323, 20324, 23746, 23747, 23748 and plot number 32 with shop in Ngong town. The court order caution was registered against all the above land titles as ENTRY No. 7, 6, 10, 11, 9, 5 in the Green Cards which stated "NO DEALINGS UNTIL SUCCESSION CAUSE NO.227 OF 1980 IS FINALIZED AT THE HIGH COURT AT NAIROBI". In some others titles, there was an addition of "NO DEALINGS TO THE REGISTERED PARCELS UNTIL APPLICATION AT THE COURT OF APPEAL 272/2002 IS DETERMINED".

7 COURT OF APPEAL CAUSE NO.272 OF 2002

Nepruko Munguti was not satisfied with 2001 ruling and in 2002 she filed an appeal against the Judgement of Kaplana Rawal's in the Court of Appeal. The case has not been determined as of 2008 and is scheduled to be heard before the end of the year. However, the appeal did not stay the implementation of 2395/2003 of the judgement of Kaplana Rawal.

WORRYING TIME TAKEN IN THE CASE.

The case was filed in the year 2002 and the first time to be listed for hearing was February 2008, six years after filling. The script is simple. What is being prayed for by NEPRUKO is for the Court of Appeal to find fault with Justice Kaplana Rawal judgment that Siameto Munguti had two other wives besides Nepruko and her three children, one of them adopted.

Hearing time was February 2008 and Justices Aganyanya, Waki and Okubasu adjourned it due to reported overnight sickness of the appellant's counsel and without considering the respondents plight and the time the appeal is taking in court. A probable date for hearing is November 2008. Imagine what frustration



for the traumatized poor family who cannot conclude inheritance matters 35 years after the death of Siameto Munguti.

The issues in the Court of Appeal do not require the presence of anybody to know whether appeal is allowed or not. The three judges can read the literature ranging from the chief's office in 1996 to Judge Kaplana Rawal's Judgment in 2001. Then inform the advocates of both parties of the outcome. Everybody knows Nepruko never formalized her divorce from Ole Kerore even after bearing two sons while living with Siameto Munguti

8. **(I) HIGH COURT OF KENYA CAUSE NO.2395 OF 2003
(CONFIRMATION OF GRANT)**

The appeal case filed by Nepruko Munguti did not stay the execution of judgment of 227/80 in 2001. That is why succession cause was filed as 2395 of 2003. This is how the letter of administration was granted to Resiato Munguti, Noongipa Munguti and Nepruko Munguti. Confirmation of the grant 2395 of 2003 states the three widows and their children share the property of the late Siameto Munguti equally amongst themselves.

(II) HIGH COURT AT NAIROBI 2395/2003 (application for security)

Confirmation of grant 2395/2003 could not be implemented by demarcation of land as recommended. Reason being potential of violence arranged by trespassers with the police at Ngong station. See criminal case 2576 of 2007 at Kibera Court. Resiato and Noongipa applied to the court to issue an order compelling police to provide impartial security during demarcation.. This case has grown into a full blown legal battle spanning four and half years.

CORRUPTION

The illegal nature of transactions going on about this parcel of land when the succession war is going has spawned corruption in many places

(a) PROTECTION FEE AT NGONG POLICE STATION

The trespassers holding illegal titles have been working round the clock to seek ways and means of legalizing the titles. These persons are said to be paying protection fee to policemen at Ngong police station. The firm verbal instruction is that, should any member of the Resiato and Noongipa family be spotted near or on what was NGONG/NGONG/27 they should be alerted for possible action. This has resulted into unprecedented harassment such that members of the families of Resiato and Noongipa fear to go to Ngong Town. This has culminated in trespass case at KIBERA SENIOR RESIDENT MAGISTRATE COURT 2576 OF 2007:- STATE VERSUS PARTRICK SIMIREN MUNGUTI WITH NEPRUKO MUNGUTI AND SIALO MUNGUTI AS COMPLAINANTS.



NB: - Patrick Simiren Munguti, Nepruko Munguti and Sialo Munguti have been named in confirmation of grant 2395/2003 as son, widow and daughter of the late Siameto Munguti.

The most shocking and baffling aspect of this case is that, the investigation officer and the prosecutor have declined to investigate succession documents 2395/2003, 227/80 and 272/2002 which have been supplied to them as photocopies.

The trespassers misguided action emanates from a feeling that the bona fide beneficiaries will despair and leave the property to them and therefore legitimize the illegal titles through misguided notion of adverse possession.

(b) ILLEGAL JUNIOR COURT CASE INTERVENTION (MILIMANI COMMERCIAL COURT VERSUS HIGH COURT OF KENYA, NAIROBI)

The trespassers holding illegal titles have been working round the clock to seek ways and means of legalizing the titles. That is how they chose one of them Mr. Kennedy Obara Ondieki in collusion with the Land Control Board, Kajiado Land Registrar, Mr. Nyantika and Nepruko to sue Nepruko in Milimani Commercial Court to redress a commercial debt. This cause 123 of 2006, KENNEDY OBARA ONDIEKI VERSUS NEPRUKO SIAMETO MUNGUTI which leaves the following questions begging for answer

- (i) Respondent Nepruko does not appear to have notified the magistrate of the existence of High Court cases 227/80, confirmation of grant 2395/2003, Tribunal's (1999) decision and Court of Appeal 272 Of 2002. Is this lying to the court by deliberate omission of known facts? Can this be classified as perjury?
- (ii) The SRM at Milimani Commercial Court, Mr. Cherono in approving the order by consent, he does not appear to ask what type of cautions and who launched them. Did he know that he was lifting cautions registered by the High Court of Kenya and the Court of Appeal both of them superior courts? Can the Chief Justice Evan Gicheru inquire into competence of Mr. Cherono for inability to interrogate a simple case and take remedial action?
- (iii) Mr Ondieki had sued Nepruko alone as seen on 123/2006. How come the magistrate included the rest of titles under High Court caution in his order?
- (iv) What is the content of Nepruko's affidavit that mesmerized Mr. Cherono, the Milimani Commercial court magistrate to overlook the orders of the High Court of Kenya?



(C) KAJIADO DISTRICT LAND REGISTRY

The Kajiado District Land Registrar, clearly knowing the SRM Milimani Commercial Court is junior to the High Court and Court of Appeal, removed ENTRY NO.7, 9, 6, 10 & 11 from the Green Cards of parcels of land Ngong/Ngong/20319, 20320, 20321, 20322, 20323, 20324, 23746, 23747, and 23748. He has gone ahead to give false recommendations to subdivide and transfer the above parcels of land to the Oololaiser land Control Board.

(d) OLAIKER LAND CONTROL BOARD

Oololaiser Land Control Board to be investigated for granting consent to subdivide and transfer the above parcels of land through the ILLEGAL SPECIAL LAND CONTROL BOARD MEETINGS. All members are aware of the ongoing cases since the chief of Ngong is a member and he got copy of the land Tribunal through the District Commissioner who is a member of LCB though represented by the local District Officer as chairman

9. JUDICIARY OPEN DAY 18th February 007

This case was dramatically presented by Stanley Konana who is seen on one of the Daily Nation addressing the congregation Chief Justice Evan Gicheru verbally directed. Justice Kaplana Rawal to see quick conclusion of the case. One year later and things are worse off. That appears a wasted effort by Resiatio and Noongipa and an apparent waste of public resources.

REQUEST

Justice Evan Gicheru's attempt to open the judiciary to the people should continue. A special request for him to invite Resiatio and Noongipa into his chambers to see first land the people the inefficiency in the judiciary endures.

10. CAVEAT EMPTOR

Published in the Daily Nation of 27th November 2007. Copies were taken by hand to the District Land Registrar, Mr. Lukoko Were, the District Officer, Ngong, Mr. Morekwa and the Oololaiser land control board clerk Mr. Nkuruna .

The group continued subdividing and selling the subject land as if nothing happened. What is the legal force of a Caveat Emptor? How is it enforceable? Contempt?

Our request is to investigate the number of transactions effected after caveat emptor publication

21



11. **KAJIADO DISTRICT COMMISSIONER:- CHAIRMAN OF OLOOLAISE
LAND CONTROL BOARD:-** A registered letter of complaint dated
22/10/2007 was sent by Patrick Simiren Munguti. Advance copies were given to
D.O Ngong Division and the OCS Ngong police station. (copy of Postal
Corporation of Kenya receipt attached for ease of reference)

To investigate how many transactions have been completed after receipt of the
letter by Land Registrar and the Land Control Board.

Yours truly,

Noongipa Munguti
Widow of late Siameto Munguti





PARTRIC SIMIREN MUNGUTI
P.O BOX 32097-00600
NAIROBI

Mobile No.0720715891

19TH DECEMBER 2008

MAJOR GENERAL HUSSEIN ALI
COMMISSIONER OF POLICE
POLICE HEADQUARTERS, HARAMBEE AVENUE
P.O BOX 30083-00100
NAIROBI, KENYA

Dear Sir,

COMPLAINT AGAINST NGONG POLICE BRUTAL AND ILLEGAL INTERFERENCE WITH SUCCESSION CAUSE 2395/2003 OF THE LATE SIAMETO MUNGUTI

TRESPASS CAUSE 3576/2007 AT KIBERA SENIOR RESIDENT MAGISTRATE COURT, NAIROBI: - **REPUBLIC – VERSUS- SIMIREN MUNGUTI**

I am an adult male of sound mind. I do remember that, on June 2nd 2007 at around 11 am, OB38/2/6/07 I was arrested by your Police officers from Ngong police station on allegation of trespassing on my late father's (Siameto Munguti) land. He died intestate at Kibiku Ngong in 1974 and was survived by three widows viz Resiato, Noongipa, Nepruko and twenty three children.

The three widows applied for grant of letters of administration which was granted in SUCCESSION CAUSE 2395 OF 2003 as seen on the attached photocopy. Confirmation of grant followed soon after, see photocopy attached. In the grant, the parcel of land Ngong/Ngong/27 was to be shared equally by the widows while the shop on plot Ngong Township /32 was to be sold and proceeds shared equally by the widows.

The confirmation of grant to share the estate of late Siameto Munguti could not be executed due to illegal and illogical interference by the OCS at Ngong police station at the behest of Elizabeth Sialo. On June 2nd 2007, I went to plant trees on my mother's portion of Ngong/Ngong/27. But I was surprised to see a contingent of policemen from Ngong Police Station in a Land Rover and headed by one Inspector Rotumo.

I was arrested together with others and taken to Ngong Police Station. I presented copies of grant 2395 of 2003 and its confirmation to explain my innocence but all in vain. The rest bought their way out and I was confined in the police cells from 2nd to 6th June 2007

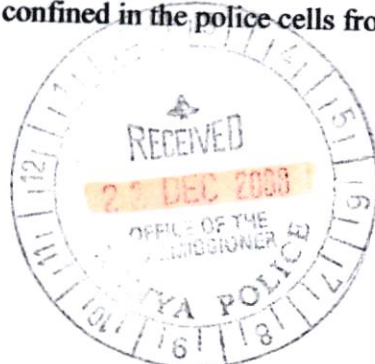



when I was ruined in Kibera Court. The case is coming for hearing on 30th December 2008.

Sir, I am now complaining to you for the unlawful arrest and confinement by your officers. If you do not withdraw the case before the hearing date of December 30th, 2008 and I happen to be acquitted of the alleged offence, I will have no option but to sue your good office.

Sir, I look forward to hearing from you at your earliest convenience.

Thank you.

Yours faithfully,

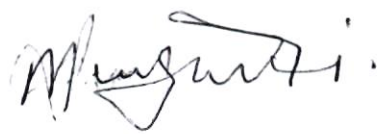

Patrick Simiren Munguti.

COMPLAINANT

11



Rulling 7th October 2009

7th October 09

REPUBLIC OF KENYA

IN THE CHIEF MAGISTRATES COURT AT KIBERA

CRIMINAL CASE 3576 OF 2007

REPUBLIC.....PROSECUTOR

VERSUS

PATRICK SIMILEN MUNGUTI.....ACCUSED

SUBMISSIONS OF NO CASE TO ANSWER

Patrick Similen Munguti was charged with two counts. The first one being:

1. **COUNT 1 - TRESPASS WITH INTENT TO ANNOY CONTRARY TO SECTION 3(1)(a) OF THE TRESPASS ACT CAP 294 LAWS OF KENYA.**

PATRICK SIMILEN MUNGUTI on the 2nd day of June, 2007 at Kibiko reserve in Kajiado District of the Rift Valley Province, trespassed the farm of **NEPRUKO MUNGUTI SIAMETO NGONG/NGONG/37848** with intent to annoy her by fencing the farm and planting trees without her consent.

2. **COUNT 11 – TRESPASS WITH INTENT TO ANNOY CONTRARY TO SECTION 3(1)(a) OF THE TRESPASS ACT CAP 294 LAWS OF KENYA.**

PATRICK SIMILEN MUNGUTI – On the 2nd day of June, 2007 at Kibiko ‘B’ in Kajiado within Rift Valley province, trespassed in the farm of **ELIZABETH SIALO MUNGUTI NGONG/NGONG/38912** with intent to annoy her by planting trees and fencing without her consent.

The charge facing the accused is therefore trespass. For a charge of trespass to stand, there should not be a competing claim. However in this case, both Nepruko Munguti Siameto and Elizabeth Sialo Munguti **knew that NGONG/NGONG/37848 and**



REPUBLIC OF KENYA

IN THE HIGH COURT OF KENYA AT NAIROBI

MISCELLANEOUS CIVIL APPLICATION NO. 33 OF 2010

IN THE MATTER OF AN APPLICATION BY PATRICK SIMIREN MUNGUTI
FOR MANDAMUS CERTIORARI AND PROHIBITION

AND

IN THE MATTER OF THE KIBERA CHIEF MAGISTRATE'S COURTS,
CRIMINAL CASE NO. 3576 OF 2007

AND

IN THE MATTER OF SECTIONS 8 AND 9 OF THE LAW REFORM ACT
CHAPTER 26 LAWS OF KENYA

PATRICK SIMIREN MUNGUTI.....APPLICANT

VERSUS

THE CHIEF MAGISTRATE
KIBERA LAW COURTS.....1ST RESPONDENT
THE HON. ATTORNEY GENERAL.....2ND RESPONDENT

IN CHAMBERS ON THE 10TH DAY OF FEBRUARY, 2010
BEFORE: THE HONOURABLE LADY JUSTICE ROSELYNE NAMBUYE

ORDER

UPON READING the application presented to this Honourable Court on 5th February, 2010 Under the Law Reform Act Cap. 26 and Order 53 of the Civil Procedure Rules and all other enabling provisions of the Law together with the supporting affidavit of PATRICK SIMIREN MUNGUTI together with the annexures thereto sworn 4th February, 2010 AND UPON HEARING Counsel for the applicant in the absence of Counsel for the respondents,

IT IS ORDERED:

1. THAT the application be and is hereby certified as urgent.
2. THAT PATRICK SIMIREN MUNGUTI be and is hereby granted leave to apply:

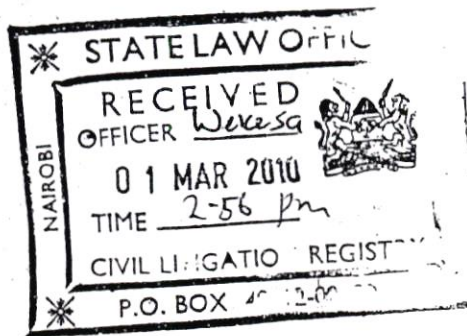



- a) THAT an order of prohibition to be issued directed to and prohibiting the Attorney General from continuing with the prosecution of Kibera Chief Magistrates Criminal Case Number 3576 of 2007 – Republic –vs- Patrick Simeren Mungiti in its present form and/or any intended variation thereof akin to the charges preferred in the said criminal charges.
 - b) THAT an order of certiorari to move into the High Court and quash the charges and the ongoing proceedings instituted by the Attorney General in Criminal Case Number 3576 of 2007 Kibera Law Courts together with proceedings and orders therein.
3. THAT the leave herein do operate as stay.
 4. THAT the substantive application be filed and served forthwith on all the interested parties including the complainants as well as all other beneficiaries in Succession Cause No. 2395 of 2003.
 5. THAT if not served forthwith, the same be served not later than 21 days from today.
 6. THAT costs be in the cause.

GIVEN under my hand and Seal of this Honourable Court this 10th day of February, 2010.

ISSUED at NAIROBI this 18th day of March 2010.
 R. W. Leo. Pa
 DEPUTY REGISTRAR
 HIGH COURT OF KENYA AT NAIROBI

PENAL NOTICE

TAKE NOTICE that this order is a valid court order issued by the aforesaid court.

TAKE FURTHER NOTICE that any party served with this order and disobeys it in part or in whole is liable for stringent punishment of contempt of court and can face a jail term not exceeding six (6) months.

4.



Signature of registered proprietor(s) present on the land at the time of Survey :

Name N. M. SIAMETO

Signature 



To Land Registrar,

KASIASSO

District

I certify that the survey has been carried out. You may now register the Mutation.

Date

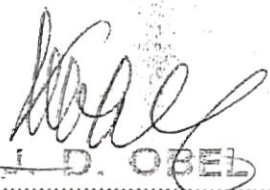

J. D. OBE
LICENSED SURVEYOR
DISTRICT / LICENSED SURVEYOR

REGISTERED THIS 1ST day of AUGUST 2006

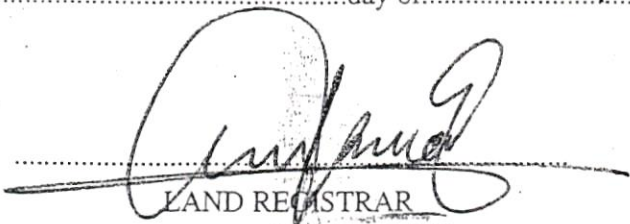

LAND REGISTRAR

D. 162

To:
Director of surveys,

Thro'
The District Surveyor

KAS

District

This Mutation has now been registered. Please amend the Registry Index Map to conform with the Diagram on Page Three (3) and supply me with a copy of the amended Registry Index Map.

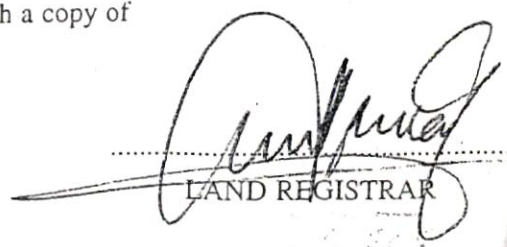

LAND REGISTRAR

SKETCH OR DEVELOPMENT PLAN

To be completed by the Registered Proprietor(s)

(Not to scale)

4120

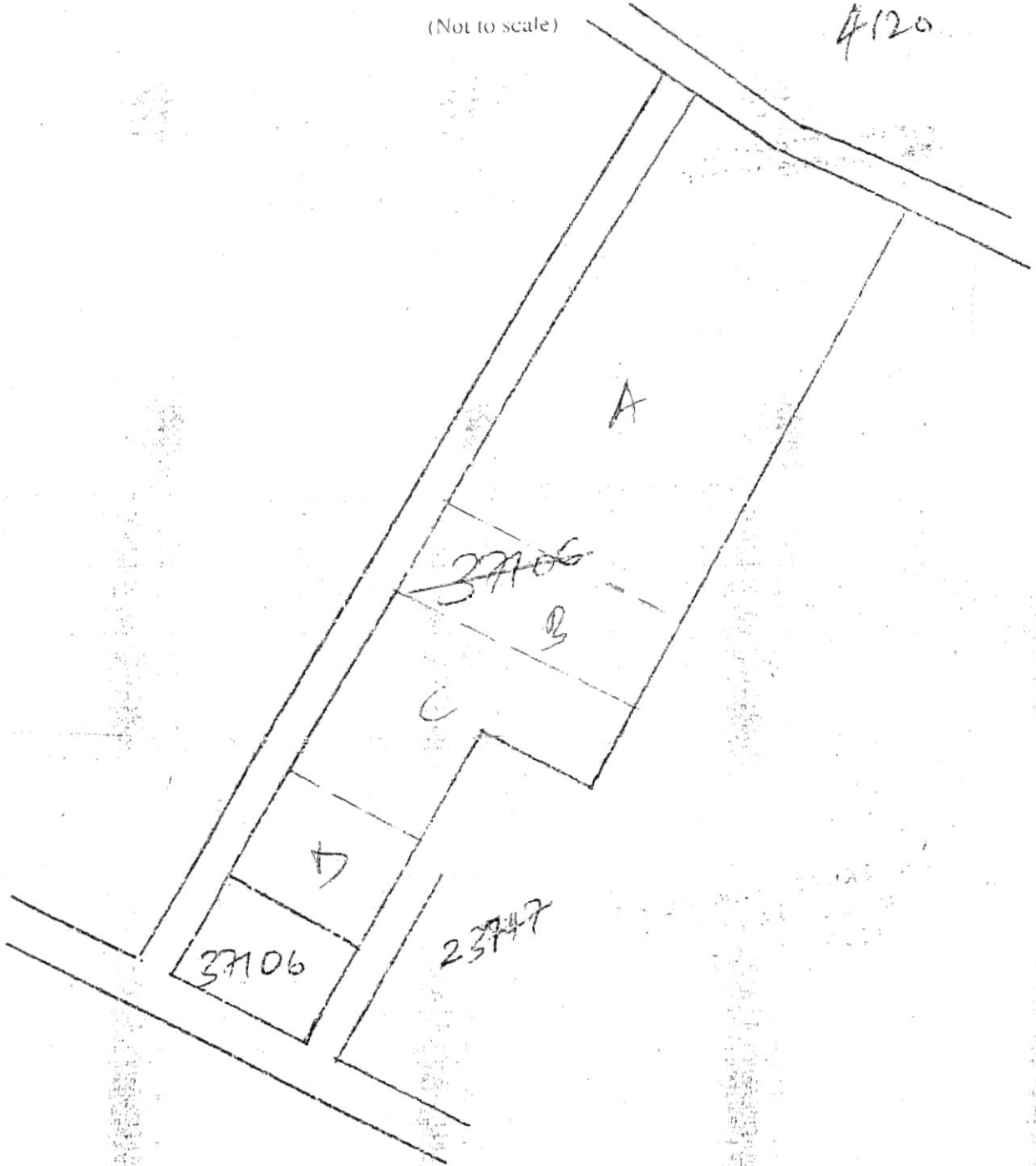

aries are to be surveyed
to the area

OR

aries are to be surveyed
st on the ground.

.....
.....
.....
.....



LTP

Signature or Marks of the
proprietor(s)

Date received for registration

01/8/06

Presentation book

No. 25/8/06

Registr.

Paid Re

Survey Fees: Shs.....

Receipt No.....

Date....

R.I.M Amendment Fee: Shs.....

900/-

Receipt No.....

0699523

Date....

REPUBLIC OF KENYA

THE REGISTERED LAND ACT, 1963

MUTATION FORM

(This form is to be completed in triplicate)

Form R.L. 29

Handwritten signatures and stamps including 'DISTRICT SURVEYOR' and 'KAJIADO'.

Title No.....

Ngona/Ngona/37706

Approximate Area.....

2.93 H-

Registry Map Sheet No.....

BSE CO 13NE

Registered Proprietors' Instructions to the Surveyor

- Present boundaries of parcel are shown on the sketch on page 2:
 - The proprietor wishes to subdivide the parcel as shown by the dotted lines on the sketch or
 - The proprietors wish to change their common boundary as shown by dotted lines on the sketch or
 - The proprietors wish to partition the parcel as shown by the dotted lines on the sketch or
 - The proprietor wishes to combine his parcels as shown by the brace on the sketch.

(b) The new parcel numbers will be:

reference and approximate area

DISTRICT SURVEYOR
P.O. BOX 400
KAJIADO
118/06

A	B	C	D	
37848	37849	37850	37851	
2.18	0.20	0.40	0.15	

- The relevant Letter or Consent to subdivide/partition the parcel is attached.
- The persons interested, and their addresses are:

NEPUNGO MUNGWI SIAMETO
ID No: 1063283
Box 75
Ngona C - Hills

They will meet the Surveyor at.....

on at a.m/p.m. or on the land at a time

(e) Please advise the Land Registrar when the mutation is surveyed and Registry Index Map amended

Signature of registered proprietor(s) present on the land at the time of Survey:

Name N. M. SIAME TO

Signature

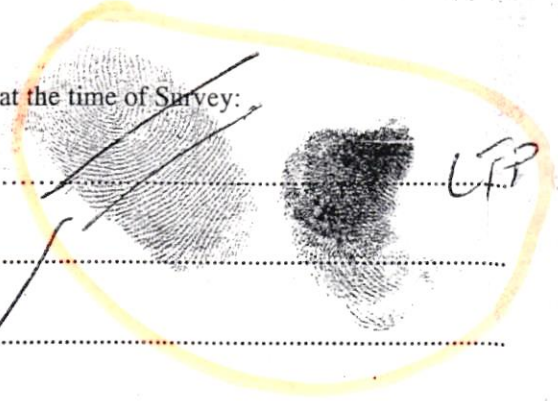

To Land Registrar,

KADISSO' District

I certify that the survey has been carried out. You may now register the Mutation.

Date 3/8/08

J. D. OBEL
LICENSED SURVEYOR
DISTRICT / LICENSED SURVEYOR

REGISTERED THIS 12TH day of SEPTEMBER 20⁰⁸

O. M. Kyalo
LAND REGISTRAR

To:
Director of surveys,

Thro'
The District Surveyor

KAD District

This Mutation has now been registered. Please amend the Registry Index Map to conform with the Diagram on Page Three (3) and supply me with a copy of the amended Registry Index Map.

O. M. Kyalo
LAND REGISTRAR

FIELD DIAGRAM AND OBSERVATIONS ON SITE

To be completed by the Surveyor
(Attach a tracing to scale where appropriate)

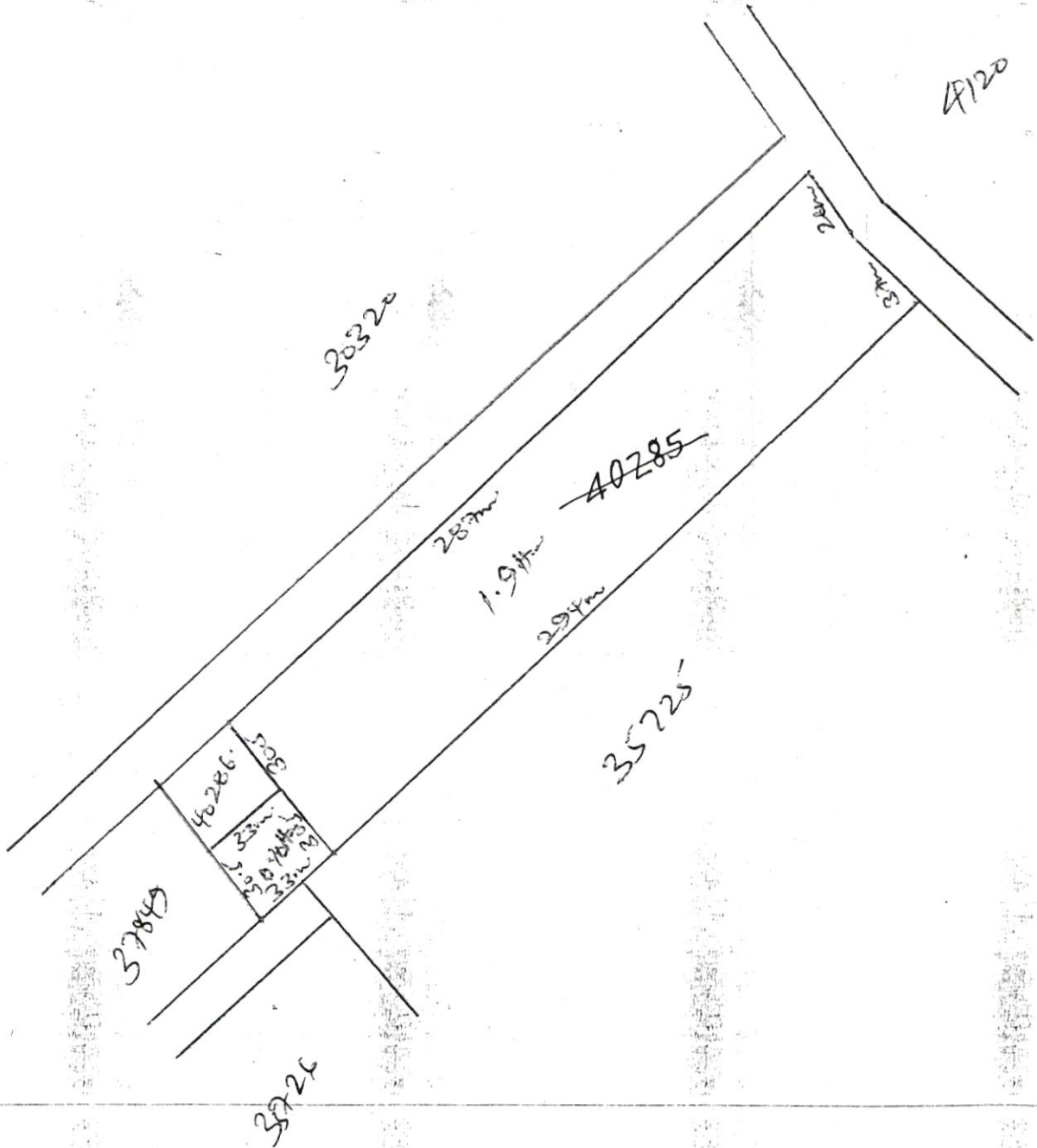

SCALE 1:2500

This is to certify that this field sketch contains the actual figures recorded by me at the time of observation and measurements in the field.

Certificate under Schedule 9 of the Survey Regulations to be provided in case the survey has been done by an Approved Assistant.

Date... 3/8/08

GEOMATIC SERVICES
Sign: *[Signature]*

SKETCH OR DEVELOPMENT PLAN

To be completed by the Registered Proprietor(s)
(Not to scale)

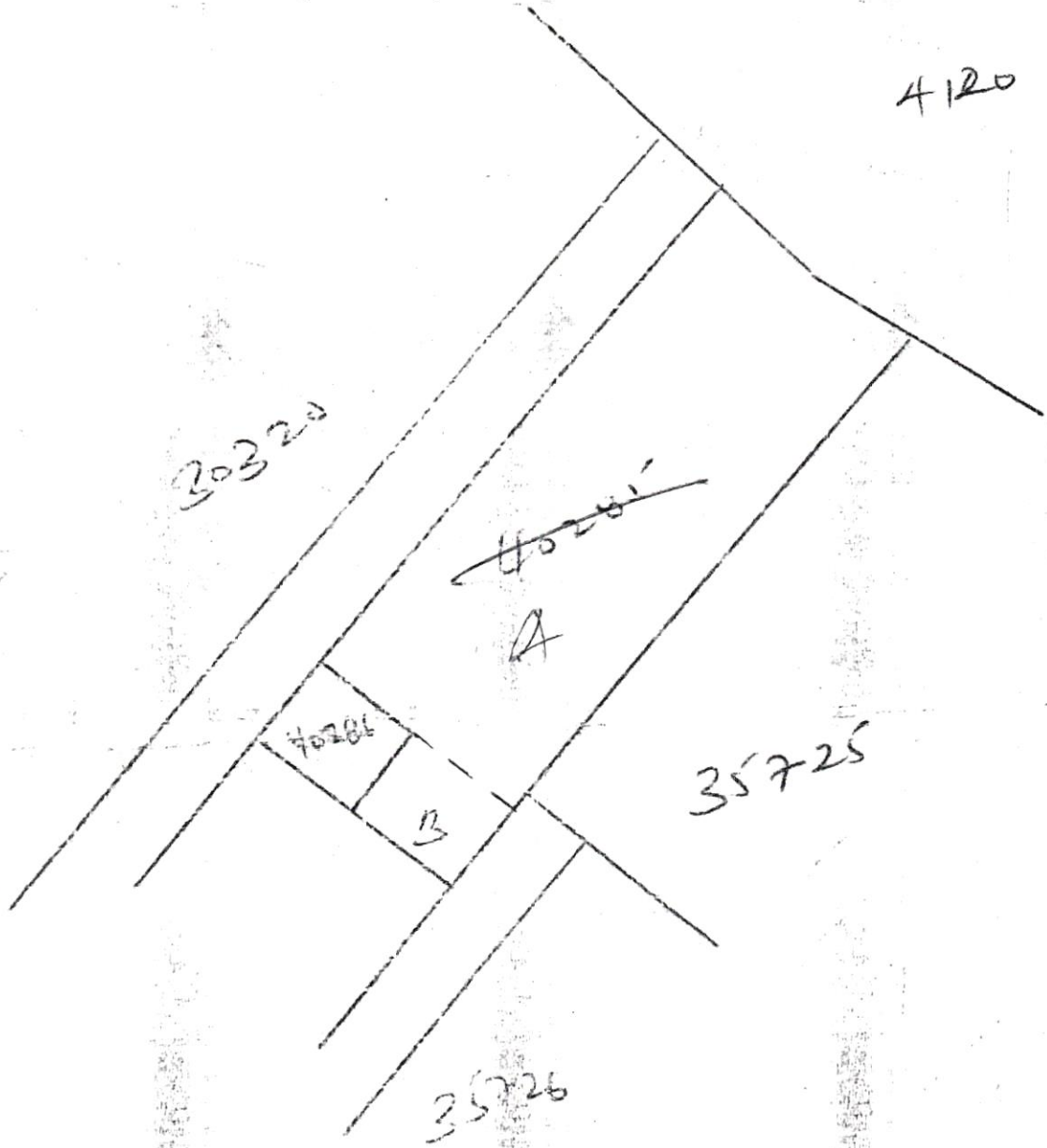

aries are to be surveyed
to the area

aries are to be surveyed
ist on the ground.

.....
.....
.....
.....



Date received for registration

18-9-08

Presentation book

No. 678/9/08

Registration Fees:

Paid Receipt No.

Survey Fees: Shs.....

Receipt No.....

Date

R.I.M Amendment Fee: Shs. 480/-

Receipt No. 10/5954

Date 12/05

REPUBLIC OF KENYA

Form R.L. 29

THE REGISTERED LAND ACT, 1963

MUTATION FORM

(This form is to be completed in triplicate)

Joseph

Title No. Ngora Ngora 40285

Approximate Area. 2.05 Hc

Registry Map Sheet No. 85E E 13DE

Registered Proprietors' Instructions to the Surveyor

- 1. Present boundaries of parcel are shown on the sketch on page 2.
 - (a) (i) The proprietor wishes to subdivide the parcel as shown by the dotted lines on the sketch. or
 - (ii) The proprietors wish to change their common boundary as shown by dotted lines on the or
 - (iii) The proprietors wish to partition the parcel as shown by the dotted lines on the sketch. or
 - (iv) The proprietor wishes to combine his parcels as shown by the brace on the sketch.

(b) The new parcel numbers will be: relevant approximate area

43068	43069				
1.95	0.10				

- (c) The relevant Letter or Consent to subdivide/partition the parcel is attached.
- (d) The persons interested, and their addresses are:

NEPUELLO MUNG'ITHI SIAMETO
 D No: 1063288
 Box 75
 Ngora - Hills

They will meet the Surveyor at..... on..... at..... a.m/p.m. or on the land at a time ap

(e) Please advise the Land Registrar when the mutation is surveyed and Registry Index Map amend

Date received for registration: 3-9-07
 Presentation book No: 09-9-07
 Registration Fees: Paid Receipt No.
 Survey Fees: Shs.
 R.I.M Amendment Fee: Shs.
 Receipt No.
 Receipt No. 45778
 Date: 03/0

REPUBLIC OF KENYA
 THE REGISTERED LAND ACT, 1963
MUTATION FORM

(This form is to be completed in triplicate)

Title No. Nwoka / Nwoka / 37848
 Approximate Area: 2.18 Hc.
 Registry Map Sheet No. 85E Ea 13 NE

Registered Proprietors' Instructions to the Surveyor

1. Present boundaries of parcel are shown on the sketch on page 2.
 - (a) (i) The proprietor wishes to subdivide the parcel as shown by the dotted lines on the sketch.
 - or
 - (ii) The proprietors wish to change their common boundary as shown by dotted lines on the sketch.
 - or
 - (iii) The proprietors wish to partition the parcel as shown by the dotted lines on the sketch.
 - or
 - (iv) The proprietor wishes to combine the parcels as shown by the brace on the sketch.

40285	40284	0.10
2.08		

--	--	--	--	--

DISTRICT SURVEYOR
 P.O. Box 70
 KAJIADO

- (b) The new parcel numbers will be: relevant approximate area
- (c) The relevant Letter or Consent to subdivide/partition the parcel is attached.
- (d) The persons interested, and their addresses are:

Nwoka Munkuti Siameto
 P.O. No. 1063283
 Box 75
 Nwoka - HILLS

They will meet the Surveyor at
 at a.m/p.m. or on the land at a time app
 on
 (e) Please advise the Land Registrar when the mutation is surveyed and Registry Index Map amend

MUT/28/200/09/07

SKETCH OR DEVELOPMENT PLAN

To be completed by the Registered Proprietor(s)
(Not to scale)

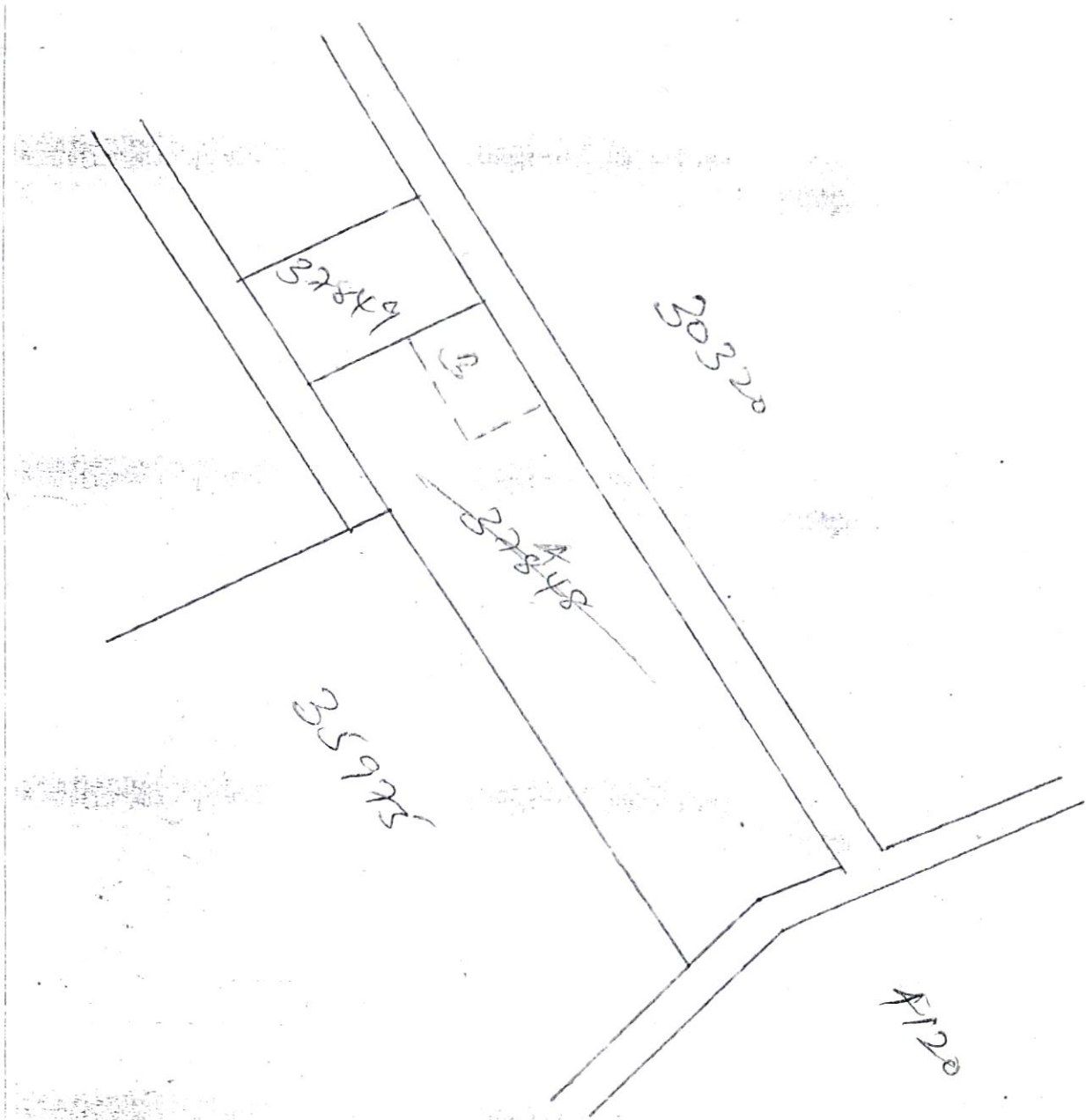

As are to be surveyed
the area

As are to be surveyed
on the ground.

NEPURKO

FIELD DIAGRAM AND OBSERVATIONS ON SITE

To be completed by the Surveyor
(Attach a tracing to scale where appropriate)

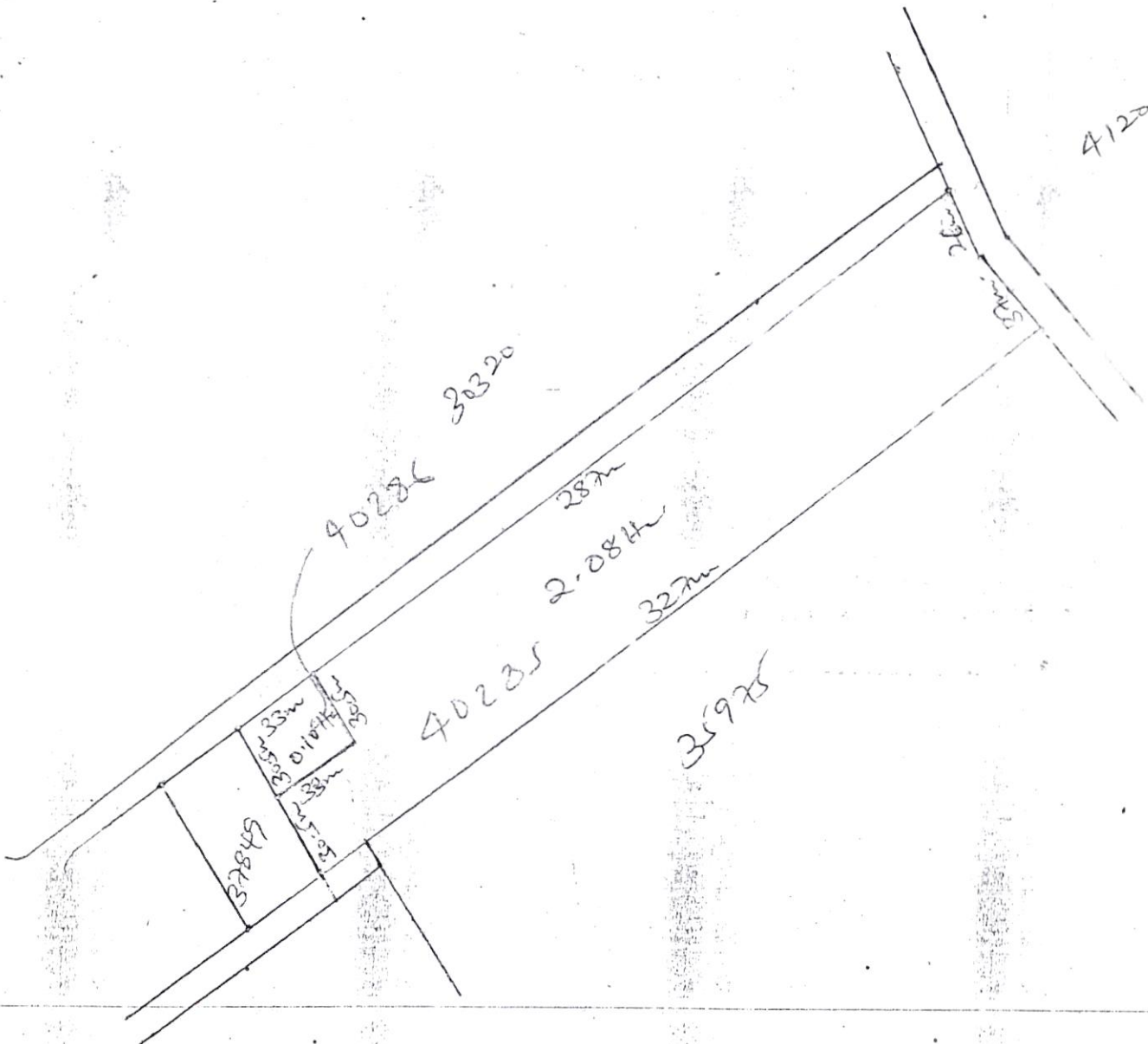

This is to certify that this field sketch contains the actual figures recorded by me at the time of observation and measurements in the field.

Certificate under Schedule 9 of the Survey Regulations to be provided in case the survey has been done by an Approved Assistant.

Date 23/7/07

Signature of registered proprietor(s) present on the land at the time of Survey:

Name: N. M. SIMONE

Signature: NEPUBUKO

To Land Registrar,

KAJIADU

District

I certify that the survey has been carried out. You may now register the Mutation.

Date: 23/7/07

D. R. R. AGANYO & ASSOCIATES

P. O. BOX 11738 NAIROBI

DATE: 23/7/07

DISTRICT/ LICENSED SURVEYOR

[Signature]

REGISTERED THIS

3rd

day of

SEPTEMBER 07

LAND REGISTRAR

(CAJIAADU)

To:

Director of surveys,

Thru

The District Surveyor

District

This Mutation has now been registered. Please amend the Registry Index Map to conform with the Diagram on Page Three (3) and supply me with a copy of the amended Registry Index Map.

LAND REGISTRAR

CAJIAADU

23/7/07

[Signature]

Teresia Nalotuesha Munguti I/D No. 32926294
P.O Box 55, Narok

19/11/2014

Hon. Justice Mutunga
President of the Supreme Court
Nairobi
Dear Sir

**SUCCESSION OF THE LATE SIAMETO MUNGUTI:- CASES KAJIADO SENIOR
RESIDENT MAGISTRATE COURT SRM 4/1999, HCC 227/80, COURT OF APPEAL
CAUSE 272 OF 2002, HCC 2395 OF 2003, MILIMANI COMMERCIAL COURT CAUSE
SRM 123 OF 2006, KIBERA MAGISTRATE'S CRIMINAL COURT CASE 3576 OF 2007,
ORDER OF MANDAMUS CERTIORARI HCCC30 OF 2010,**

**CONSTITUTIONAL & HUMAN RIGHTS COURT 154 OF 2013, ELC, NAIROBI 432 OF
2013 AND SUCCESSION CAUSE HCC 2395 OF 2003(REVISITED IN 2014 WITH
THREE NEW PETITIONS)**

**REPUBLIC- VERSUS- PATRICK SIMIREN MUNGUTI:- KIBERA LAW COURT 3576
OF 2007.**

I am the widow of the late Partick Simiren Munguti who is a beneficiary of the estate of his late father Siameto Munguti as per confirmation of grant 2395 of 2003. Simiren was charged with criminal offence of trespassing on Ngong/Ngong/37848 which was a cancelled title as per Lady Justice Kalpana Rawal ruling in succession cause 227 of 1980 on November 2001.

The case was instigated by Nepruko and Sialo Munguti who are step mother and sister respectfully. They were being assisted financially by those who participated in fraudulent subdivision of the suit property through fraudulent Milimani Commercial court cause 123 of 2006. A copy of a list of some of them is attached herewith for ease of reference.

The complainants Nepruko and Sialo Munguti as well as the defendant Patrick Simiren Munguti are all dead. I would like to know the fate of the case. I have a feeling Athman Salim Mohamed and 48 others might use it intimidate me and my children as they have brought numerous cases through the Constitution and Human Rights court 154 of 2013, Environment and Land Court case 452 of 2013 and now as in case 2395 of 2003. They have also financed the redundant case Simon Munguti to file application for nullification of Lady Justice Nambuye in succession cause 2395 of 2003, since a similar case by mother Nepruko was lost in 2006.

The group has been accusing Patrick Simiren of writing letters to the police, judiciary, the Law Society of Kenya and other human Rights groups.



The persons who have fraudulently purchased our land from our adversary Simon Munguti appear to be immune to law. Filing new cases through Oraro & Company advocates indicates they are ready to do anything under the sun, including but not limited to trumping criminal charge against us, to disinherit us for how do they claim constitution right to own our land. Their illegal activities are known to all for a long time.

I need protection from them to enjoy the property with my children.

Yours faithfully

Teresia Munguti

40



REPUBLIC OF KENYA

IN THE HIGH COURT OF KENYA AT NAIROBI

PROBATE AND ADMINISTRATION CAUSE NO. 227 OF 1980

IN THE MATTER OF THE ESTATE OF SIAMETO OLE

MUNGUTI (DECEASED)

PROCEEDINGS

16.09.08

Coram: Rawal, J

Theri - court clerk

Mr. Nyarage for the Objector

Mr. Wetangula for the Administrator

This is the exhibit marked RM-7
 referred to in the annexed affidavit of
Kerrato & Nwangira
 Sworn before me this 11th
 day of September
 2008
[Signature]
 Clerk of the Court

COURT:

As per my Judgment the revoked grant be submitted to the court for cancellation within 15 days.

K.H. RAWAL

JUDGE

16.9.08

I CERTIFY THIS IS TRUE COPY OF THE ORIGINAL
 DATED 30th September 2008
[Signature]
 DEPUTY REGISTRAR
 HIGH COURT OF KENYA
 NAIROBI



P.K NJOROGE & COMPANY

ADVOCATES & COMMISSIONERS FOR OATHS

P. K NJOROGE LLB (Hons) NBI DIP. LAW (KSL)

P.O Box 49658
Nairobi, Kenya
Tel: 225193/220160
Fax: 244763
Email: penka@insightkenya.com

Hand Deliveries:
Jubilee Exchange House
2nd Floor, Room 245 &256
Mama Ngina Street

Our ref: PKN/708/00

Date: 17h October 2008

Your Ref:

1. Elizabeth Sialo.
2. The District Land Registry (Kajiado land Registrar).
3. Kajiado District Surveyor.
4. The District Officer Ngong (Land Control Board).
5. The O.C.S. Ngong Police Station.

URGENT

Dear Sirs,

RE: SUCCESSSION CASE NO.227 OF 1980
IN THE MATTER OF THE ESTATE OF SIAMETO OLE MUNGUTI,
(DECEASED)

This is to bring to your attention that the High Court (Hon. Lady Justice Rawal) dated 16th September, 2008. The order was granted on the premises that the grant which involved the distribution of L.R.Ngong/Ngong/27 was being misused by parties to cause illegal subdivision and sale of portions to unsuspecting members of the public.

Please resist the use of your good offices to cause trouble to the beneficiaries.

Your attention is drawn to the provision of 45 of the law of Succession Act chapter 160 Laws of Kenya which makes it a crime, any act of meddling with the estate of a deceased.

Be guided accordingly.

Yours Faithfully,

P.K.NJOROGE.

Cc: *The Deputy Register,
High Court of Kenya,
Family Division,
Nairobi.*



D.B. Wati & Co.

ADVOCATES & COMMISSIONERS FOR OATHS

D.B. Wati LLB (HONS)

PIN No. A001213440Z

VAT No. 0144011R

Your Ref

Our Ref: **DBW/MISC/9/09**

Date **10/9/09**

KENDA HOUSE

Second Floor
Tom Mboya Street

P.O. Box 25201-00100

NAIROBI, KENYA

Landline: (020) 2128551

Safaricom: 0722-406094

Zain: 0738-539573

Email: davidwati@yahoo.com

The Land Registrar
Kajiado

Dear Sir,

RE: SUCCESSION CAUSE NO.2395 OF 2003
IN THE MATTER OF THE ESTATE OF SIAMETO OLE MUNGUTI
(DECEASED)

On 8th September, 2009 through our agent a one Peter Mutua, we requested for official searches of all subdivisions of the former **NGONG/NGONG/27**. This was pursuant to an order issued on 7th August, 2009 by Her Honour Lady Justice Jean Gacheche. The said Peter Mutua paid the requisite charges in respect of 25 parcels of land he reckoned were the subdivisions thereof. To his dismay, your officers turned hostile when they realized that the requested information concerned **NGONG/NGONG/27** to the extent of contending that the order was in any event not directed to your office.

Unless you hand over all the information pertaining to the subdivisions of **NGONG/NGONG/27** including the official searches and certified copies of the extract of the register thereof, we shall go back to court for further orders.

Yours faithfully,

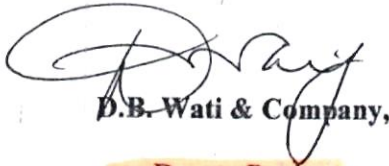
D.B. Wati & Company,

c.c. Deputy Registrar
High Court of Kenya
Nairobi

c.c. Land Registrar
Ardhi House
Nairobi





REPUBLIC OF KENYA
IN THE HIGH COURT OF KENYA AT NAIROBI

SUCCESSION CAUSE NO. 2395 OF 2003

IN THE MATTER OF THE ESTATE OF SIAMETO OLE MUNGUTI
(DECEASED)

AFFIDAVIT

I, PENUEL NYAMWEYA residing at and of Post Office Box Number 78 Kajiado do hereby make oath and state as follows:-

1. **THAT I am the Land Registrar, Kajiado.**
2. THAT I wish to present the official searches and extracts of the Register of all resultant subdivisions of NGONG/NGONG/27 the subject matter herein.
3. THAT NGONG/NGONG/27 was first subdivided into six parcels namely, 20319, 20320, 20321, 20322, 20323 and 20324.
4. THAT the aforesaid parcels of land have intum been subdivided as sketched out on the annexed diagram marked "PN-1".
5. THAT annexed hereto as a bundle are true copies of the official searches for the subsisting parcels of land namely NGONG/NGONG/37710, 37711, 37398, 37399, 374000, 46888, 46889, 39398, 39399, 39400, 39401, 39402, 39403, 39404, 39405, 39405, 39407, 39204, 39405, 38317, 38318, 41752, 41753, 41754, 41755, 41756, 43265, 43266, 43267, 43268, 43269, 43270, 43271,



43272, 47290, 47291, 37849, 37850, 37851, 46975, 46976, 46977, 40282,
40283, 40284, 40285, 40286, 35975, 35976, 35977, 38312, 38313, 38314,
42132, 42133, 42134, 42135, 42136, 42137, 42138, 42139, 42140, 42141,
42142, 42143, 42144, 42145, 42145, 42146, 42147, 42148, 42149, 42150,
42151, 42152, 42153, marked "PN-2".

- 6. THAT also annexed hereto as a bundle are true copies of the extracts of the register for the resultant subdivision of NGONG/NGONG/27. *Marked "PN-2"*
- 7. THAT what is deponed to hereinabove is true and within my own knowledge, save where otherwise expressly stated.

SWORN by the said]
PENUEL NYAMWEYA]
 At Nairobi]
 This 1st day of July 2010]
 Before me]
 SUSAN MAIRA]
 ADVOCATE]
 COMMISSIONER FOR OATHS]
 P. O. Box 61502 - 00200, NAIROBI.]
Commissioner for Oaths]

[Signature]

 Deponent

Drawn & filed by:
 D.B. Wati & Co. Advocates
 2nd Floor, Kenda House
 Tom Mboya Street
 P.o. Box 25201-00100
 Nairobi

To be served upon:
 Asiema & Co. Advocates
 Occidental Plaza
 Nairobi



90



Received



REPUBLIC OF KENYA

Received 4 pm.

IN THE HIGH COURT OF KENYA T NAIROBI

Received 5 pm

SUCCESSION CAUSE NO. 2395 OF 2003

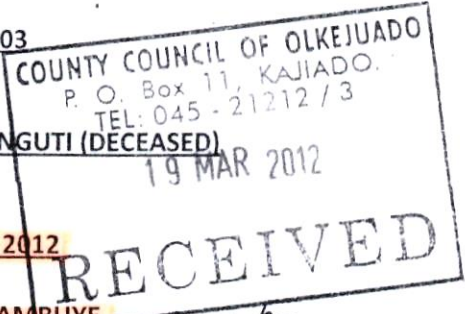

IN THE MATTER OF THE ESTATE OF SIAMETO OLE MUNGUTI (DECEASED)

20/3/12

IN COURT ON 17TH DAY OF FEBRUARY, 2012

BEFORE THE HONORABLE LADY JUSTICE NAMBUYE

Received 4.35 pm.

Received 12.45 pm.

ORDER

UPON READING the publication presented to this honourable court on the 28th day of November, 2005, by the 1st and 2nd administrators under Rule 73 of the Probate and administration Rules; UPON READING the supporting affidavit of RESIATO MUNGUTI and NOONGIPA MUNGUTI sworn on 28th November, 2005 together with the annexures thereto; AND UPON HEARING counsel for the 1st and 2nd administrators and counsel for the 3rd administrator;-

IT IS HEREBY ORDERED:-

1. THAT the application dated 30th September, 2009 which sought to facilitate the finalization of the ruling of Gacheche J of 7th August, 2009 be and is hereby marked as spent upon filing by the land registrar of the Replying Affidavit deponed on 1st July, 2010 and filed on 2nd July, 2010 on one hand and on the other hand upon delivery of this ruling.
2. THAT the certificate of confirmation of grant issued on 26th September, 2006 be and is hereby rectified so that the names of the beneficiaries includes the aliases as follows:
 - a) RESIATO MUNGUTI also known as RESIATO OLE MUNKUTI.
 - b) NOONGIPA MUNGUTI alias KAGUINI SIAMETO LEMUNGUTI.
 - c) KESWE OLE MUNGUTI alias LEMUNKUTI OLE NAISENEA.
 - d) MONGA OLE MUNGUTI alias MOONGA OLE MUNGUTI.
 - e) MICHAEL SIRONKA MUNGUTI alias MICHAEL SIRONKA MUNKUTI.
 - f) KENNEDY PALSIMEI OLE MUNGUTI alias KENNEDY PARSIMEI OLE MUNGUTI.
 - g) BENSON LEMERIA OLE MUGOT alias BENSON LEMERIA OLE MUNKUTI.
3. THAT the Land Registrar, Kajiado do cancel the transmission of NGONG/NGONG/27 to NEPRUKO MUNGUTI SIAMETO and all the mentioned as well affected resulting subdivisions of NGONG/NGONG/27 deponed in the replying affidavit of the Land

Received 21/3/2012 5.10 pm

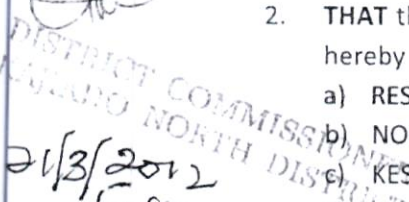

8.



Registrar **PENUEL NYAMWEYA** sworn on 1.7.2010 and filed on 1.7.2010 be reverted back to parcel number **NGONG/NGONG/27** as it was originally registered in the name of the deceased.

- 4. **THAT** the OCS Ngong Hills Police Station do provide security during and supervise the subdivision of **NGONG/NGONG/27** and settlement thereon by the beneficiaries as per the certificate of confirmation of grant issued by the court.
- 5. **THAT** upon reversion of title into the original title number **NGONG/NGONG/27** in the name of deceased, the resulted reverted title to be distributed in accordance with the distribution shown on the confirmed grant.
- 6. **THAT** thereafter the parties to proceed according to law.
- 7. **THAT** there will be general liberty to apply for enforcement orders if need be.
- 8. **THAT** each party to bear its own costs.

GIVEN under my seal hand and the seal of the court at Nairobi this 17th day of February, 2012.

ISSUED at Nairobi this 16th day of March 2012.

I CERTIFY THIS IS TRUE COPY OF
 THE ORIGINAL
 DATED 16/3/2012
 DEPUTY REGISTRAR
 HIGH COURT OF KENYA
 FAMILY DIVISION

 DEPUTY REGISTRAR
 HIGH COURT OF KENYA, NAIROBI

PENAL NOTICE

TAKE NOTICE that if any party served with his order does not comply or adheres to it he or she shall be liable to imprisonment by court for a period not exceeding six months (6 months)".

14



REPUBLIC OF KENYA
THE LAND CONTROL ACT
(Cap. 302)
DISTRICT COMMISSIONER
KAJIADO NORTH DISTRICT

APPLICATION FOR CONSENT OF LAND CONTROL BOARD
To be submitted in TRIPLICATE in respect of each transaction and
sent to or left at the appropriate office of the Commissioner of Lands

TO: THE CHAIRMAN
LAND CONTROL BOARD.

L.C.R. No. 289/2012

I HEREBY apply to the OLOOLAISER
Land Control Board for its consent to the transaction described below, and give the following
information:

1. (a) Present registered holder of interest (full name in BLOCK LETTERS):
RESIATO ENE MUNGUTI I/D NO. 6152542 AND KAGUINI SIAMETO MUNGUTI
I/D NO. 019999747

(b) Nationality KENYAN

(c) Address P.O. BOX 55, NAROK

2. (a) Proposed purchaser, transferee, mortgagee, chargee, allottee, etc. (full name in
BLOCK LETTERS) N/A

(b) If a limited liability company, names of directors, authorised and issued share
capital and principal shareholders: if a co-operative society, names of chair-
man, secretary and treasurer and total number of members—

N/A

(c) Nationality N/A Certificate No. N/A

(d) Address N/A

3. Nature of transaction (e.g. sale, gift, lease, mortgage, charge, etc.: if sale or allotment
of shares name of company, number and particulars of shares to be transferred)

SUBDIVISION OF 20.4 HECTARES INTO FOURTEEN PORTIONS: ELEVEN OF
0.80 HECTARES EACH, ONE PORTION OF 1.62 HECTARES, ONE OF 2.8
HECTARES AND ONE OF 6.7 HECTARES

4. Term (i.e. the length of time for which the land affected is to be transferred or leased
if sale or allotment of shares, authorised share capital of the company and numbers of
shares issued at date of application) ABSOLUTE

5. Description of Land—

L.R. or Parcel No. KAJIADO/ NGONG/NGONG/27

Area 20.4 HA

Locality NGONG TOWN

County Council OLKEJUADO

6. (a) Purchase price if a sale or option Sh.
 Rent Sh.
 Estimated value of the land (if a gift) Sh. *N/A*
 Amount of loan (if a mortgage or charge) Sh.
 Rate of interest (if a mortgage or charge) %

Any other information affecting the amount of the consideration, particularly regarding the description and area of crops with estimated yields and value thereof included in the purchase price

N/A

- (b) Full description and approximate value of improvements on land included in the consideration

N/A

- (c) Any other consideration passing between the parties

N/A

7. If a transfer or lease of the land—

Proposed development programme of purchaser, including funds available thereof with approximate date

N/A

Does the purchaser/lessee intend to reside on the land?

N/A

- 8.(b) Other agricultural land registered in the name of or held under contract for sale by the proposed purchaser, transferee, lessee or allottee, or any member(s) of his immediate family, or any company in which he has an interest (state the nature of any interest in such company)—

L.R. or Parcel Nos. Area

Owner *N/A*

Nature of interest

Whether contiguous to land being purchased

- (b) Particulars of agricultural land held and disposed of by purchaser or lessee in the last three years—

L.R. or Parcel Nos. District Area

L.R. or Parcel Nos. District Area

9. Farming experience of transferee

N/A

We hereby declare that the above information is true to the best of our knowledge and belief.

.....
Signature of purchaser, lessee, mortgagee, chargee, or authorized agent or agents, etc.

KAGUINI SIAMETO MUNGUTI

RESIATO ENE MUNGUTI

.....
Signature of owner, lessee, mortgagee, chargee, or authorized agent or agents, etc.



Date

Date

If spaces allowed under any particular item are insufficient for the information, a separate sheet with item numbers and duly signed by all parties or their authorized agent or agents should be attached.

Date received for registration Presentation book No. Registration Fees: Shs.
 Survey Fees: Shs. Receipt No. Paid Receipt No.
 R.I.M Amendment Fee: Shs. Receipt No. 2949264 Date 3/10/2012

REPUBLIC OF KENYA

Form R.L. 29

THE REGISTERED LAND ACT, 1963

MUTATION FORM

(This form is to be completed in triplicate)

Handwritten signature and date: 10/10/12

Title No. KAJIADO/NGONG/NGONG/27

Approximate Area. 20.47 Hectares.

Registry Map Sheet No. 148/3/8/SE & 148/3/13NE

Registered Proprietors' Instructions to the Surveyor

- 1. Present boundaries of parcel are shown on the sketch on page 2.
 - (a) (i) The proprietor wishes to subdivide the parcel as shown by the dotted lines on the sketch.
or
 - (ii) The proprietors wish to change their common boundary as shown by dotted lines on the sketch.
or
 - (iii) The proprietors wish to partition the parcel as shown by the dotted lines on the sketch.
or
 - (iv) The proprietor **wishes** to combine his parcels as shown by the brace on the sketch.

(b) The new parcel numbers will be:
relevant approximate area

A	B	C	E	F	G	H
58286	58287	58288	58289	58290	58291	58292
0.80	0.80	1.62	0.80	0.80	0.80	0.80
J	K	L	M	N	P	R
58293	58294	58295	58296	58297	58298	58299
2.75	0.80	0.80	0.80	0.80	0.80	6.70

Handwritten note: Certificate of compliance No. KAJ 3878 of 03/10/2012
 Form P.P.A 2 No 5/102/2012 of 02/OCT/2012

- (c) The relevant Letter or Consent to subdivide/partition the parcel is attached. LCR No. 128/9/2012
- (d) The persons interested, and their addresses are:

RESIATO ENE MUNGUTI ID No. 6152542
KAGUINI SIAMETO MUNGUTI ID No. 01999747
P.O. Box 55
NAROK

They will meet the Surveyor at SITE on 10.00 at 10.00 a.m/p.m. or on the land at a time appointed by him.

(e) Please advise the Land Registrar when the mutation is surveyed and Registry Index Map amended.

SKETCH OR DEVELOPMENT PLAN

To be completed by the Registered Proprietor(s)

(Not to scale)

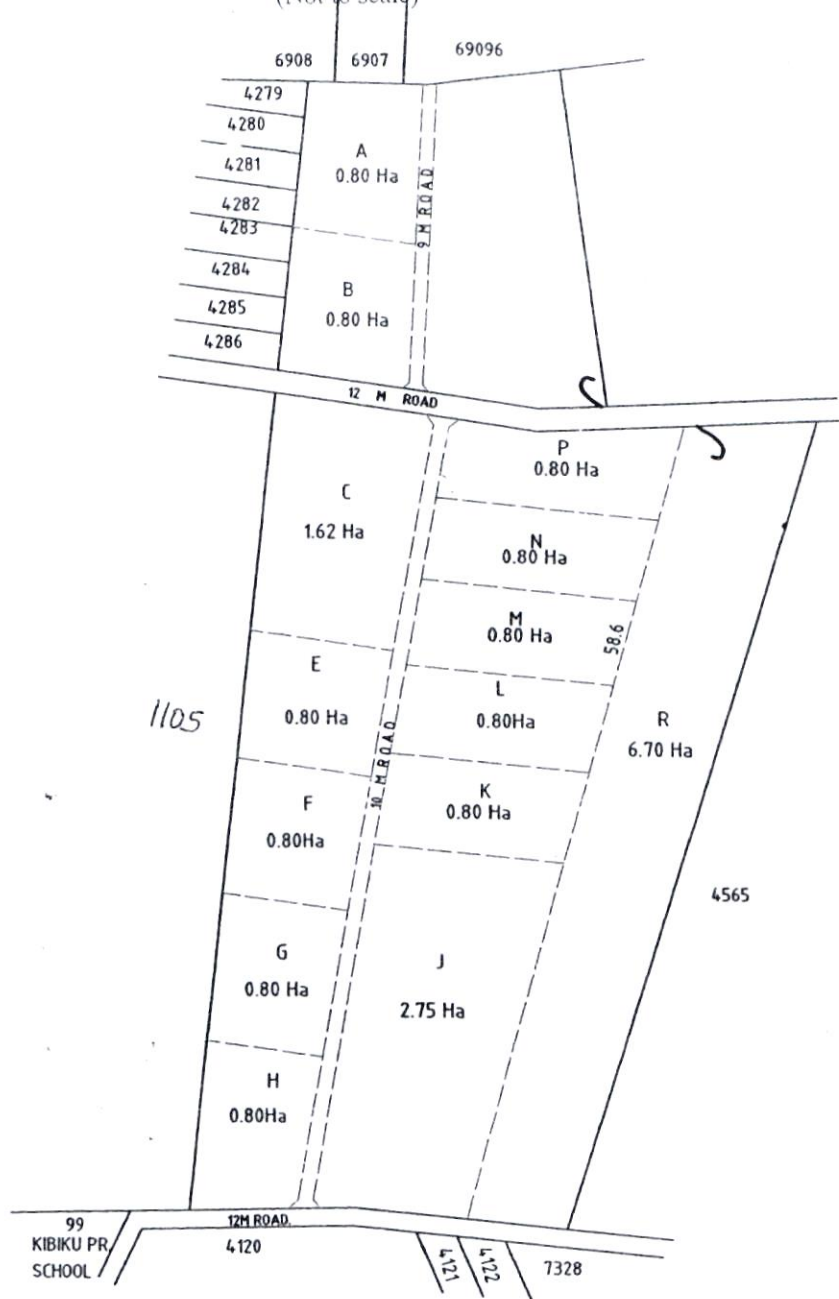

The boundaries are to be surveyed according to the area

KAGUINI

OR

The boundaries are to be surveyed as they exist on the ground.

RESIATO

.....

.....

.....

.....

Date..... 25/9/2012

Signature or Marks of the proprietors(s)

FIELD DIAGRAM AND OBSERVATIONS ON SITE

To be completed by the Surveyor
(Attach a tracing to scale where appropriate)

KAJIADO/NGONG/NGONG/27
SCALE 1 : 5000
SHEET NOS. 148/3/8S & 148/3/13NE

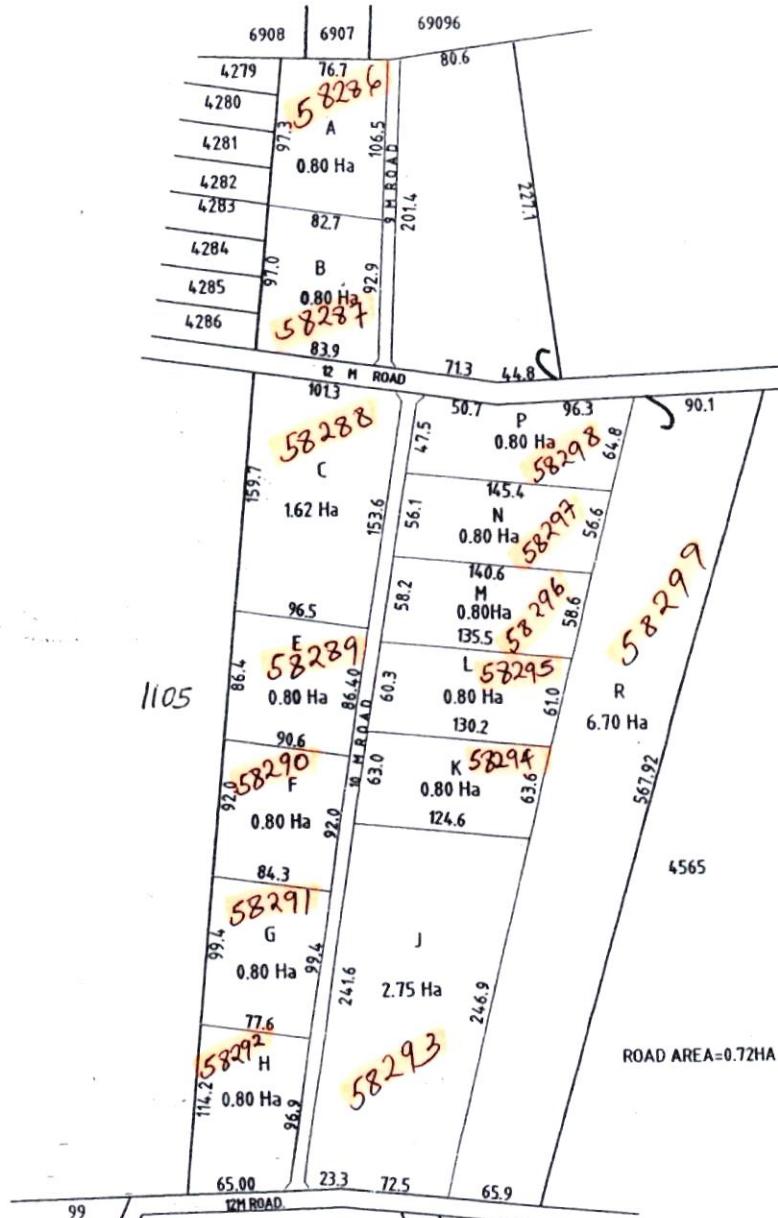

This is to certify that the field sketch contains the actual figures recorded by me at the time of observation and measurements in the field.

Certificate under Schedule 9 of the Survey Regulations to be provided in case the survey has been done by an Approved Assistant.

Date: 25/9/2012

J. D. OBEL
LICENCED SURVEYOR
GEOMATICS SERVICES

Signature of registered proprietor(s) present on the land at the time of Survey:

Name KAGUINI SIAMETO

Signature.....

RESIATO MUNGUTI



To Land Registrar,

KAJIARO NORTH District

I certify that the survey has been carried out. You may now register the Mutation.

Date..... 25/9/2012



DISTRICT / LICENSED SURVEYOR

REGISTERED THIS day of.....

LAND REGISTRAR

To:
Director of surveys,

Thro'
The District Surveyor

.....District

This Mutation has now been registered. Please amend the Registry Index Map to conform with the Diagram on Page Three (3) and supply me with a copy of the amended Registry Index Map.

LAND REGISTRAR

Date received for registration

20

No

Presentation Book

19

paid Receipt No

Registration Fees

REPUBLIC OF KENYA

R.L.19

THE REGISTERED LAND ACT 1963
(Cap. 300)

APPLICATION TO BE REGISTERED AS PROPRIETOR BY TRANSMISSION

Title No. KAJIADO/ NGONG/ NGONG/ 27

I WE RESIATO MUNGUTI AND NOONGIPA MUNGUTI

As personal representatives of SIAMETO OLE MUNGUTI Deceased HEREBY APPLY to

RESIATO MUNGUTI AND NOONGIPA MUNGUTI

be registered by transmission as proprietor in place of the deceased of his interest in the above mentioned title, and in support thereof attach the vint as required by section 119 (1) of the Act

Dated this 29 day of July 20

Signed by the Applicant(s)
In the presence of



ID NO. 6152543
PIN No. A0058812100
Signature



ID NO. 0199974
PIN No. A0062408091
Signature



RESIATO MUNGUTI AND NOONGIPA MUNGUTI

Appeared before me on the day
And, being identified by ID NOS. 6152543 AND 0199974 RESPECTIVELY

(or being known to me, acknowledged the above signatures or marks to be his (theirs) and that he (they) had freely and voluntarily executed this instrument and undertook its contents.



REGISTERED this day of 20

10



SD1

KENYA REVENUE AUTHORITY

DOMESTIC TAXES DEPARTMENT

P.O. BOX 30165 NAIROBI (00100) TEL: 310900 FAX: 253532
STAMP DUTY DECLARATION, ASSESSMENT & PAY-IN-SLIP

PART I: TO BE COMPLETED BY THE STAMP DUTY PAYER

Date of Instrument	Nature of Transaction	Title Number	LR Number	Location/Town	Area/Size	Declared Value
(1)						
(2)	TRANSFER TO R.L.T	Nhony/Nhony	NUS	NUS	58289	
(3)			58295		58296	
(4)			58287		58298	
(5)			58290		58294	
			58291			
			58292			
			58288			
			58296			

Particulars of Parties	Name	PIN	Postal Address & Code	Tel No.
(Tick as appropriate) Owner/Vendor <input type="checkbox"/>	(a) RESPAIO MUNGUJI	A0058812109		
(6) Transferor <input type="checkbox"/>	(b) SIAMEID LEMUNGUJI	A006346369F		
Others (specify) <input type="checkbox"/>	(c)			
Transferee <input type="checkbox"/>	(a) MONYA OLE MUNGUJI	A0058811269		
(7)	(b)			
	(c)			
(8) Agent/Advocate				

NB: Please provide additional information if any on the space provided overleaf

PART II: TO BE COMPLETED BY THE REGISTRAR

Amount of Duty Assessed (9) Kshs. 2000/-

Penalty Amount (Where Applicable) (10) Kshs.

Does it Qualify for Valuation? Yes(11) No(12)

Amount of Duty Payable in words: Two thousand Only

Name of Registrar/Assessor: Mumo Designation: HR Signature: [Signature] Date: 12/10/12



PART III: PAYMENT DETAILS

	Cash/Cheque Number	Drawer's Bank Name & Branch	Amount (Kshs.)
(13) Amount of Duty Paid			2000
(14) Penalty			
(15) Bank Charges			105
(16) Total Amount Paid			2100

Amount Paid in words: TWO THOUSAND ONE HUNDRED AND TEN SHILLINGS ONLY

(Amount Paid By) [Signature] (Signature) [Signature] (Date) [Date]

Form to be filled in Quadruplicate & Distributed as follows:
White - Duty Payer's Copy
Blue - Commissioner of Domestic Taxes Copy
Green - District Registrar's Copy
Yellow - Bank's Copy

(Please turn overleaf for instructions)

INSTRUCTIONS

- 0032880
- (1) For the purpose of this document, the word 'Registrar' refers to the Registrar of Titles or the Lands
 - (2) The pay - in slip will be completed in a set of 4 copies
 - (3) All boxes (1-16) must be completed, where applicable.
 - (4) Once completed and certified by the Registrar / assessor, **4 copies (i.e. original, duplicate, triplicate and quadruplicate)** will be taken by the duty payer to the stamp duty-receiving bank for payment
 - (5) **The original** to be retained by the duty payer for presentation, as evidence of payment to the Registrar for the purpose of stamping of the document, but the actual stamping will be done upon receipt of triplicate copy from the bank.
 - (6) **The duplicate, triplicate and quadruplicate copies** will be distributed as specified overleaf.
 - (7) The receiving bank and Ministry of Lands & Housing (MOL & H) officials will stamp and initial the form as designated. The receiving bank's stamp shall also bear the branch, date and time. The rubber stamp of the MOL& H officials should bear the name of the office branch.
 - (8) Payment will be made by cash, bank guaranteed cheque or banker's cheque payable to **Commissioner of Domestic Taxes, Stamp Duty Collection Account Name of Duty Payer/Agent**. However, the use of the bank guaranteed cheques will only be accepted by the bank if approved by the Commissioner of Domestic Taxes.
 - (9) In case of any queries, please contact the Commissioner Domestic Taxes, Times Tower Building, Telephone 310900, P.O. Box 30165 Nairobi (00100) FAX: 253532, E-mail: commissioner.dtd@kra.go.ke or the nearest Domestic Taxes Office or Assessor MOL&H, Ardhi house, 1st Ngong Avenue, Nairobi, Tel: 2718050, Ext. 4573/4371

ADDITIONAL INFORMATION

(please provide all details as required in part 1 overleaf)

KCB

DATE 16/10/2012

96

STAMP DUTY PAYMENT

KCB KAREN

Cash Payment Received

2100

Kenya Shillings TWO THOUSAND ONE HUNDRED ONLY

STAMPDUTY DETAILS

Payee's Name : MONGA OLE MURUTTI
PIN of Employer : A005881126Q
Tax type : STAMP DUTY



Signature : _____
TT12290GQPM1 at 13:37:12 On 16/10/2012

Thank you for banking with us. You have been served by MUTERU WAIRIMU BEATRICE

*** Advice not valid unless transaction Number shown ***

OKEN POX

5



Date received for registration 20 No Presentation Book No Registration Fees 19 paid Receipt No

R.L.7

REPUBLIC OF KENYA

THE REGISTERED LAND ACT 1963 (Cap 300)

TRANSFER BY PERSONAL REPRESENTATIVE TO PERSON ENTITLED UNDER A WILL OR ON AN INTESTACY

TITLE NO: KAJIADO/ NGONG/ NGONG 58286

I/WE RESIATO MUNGUTI AND KAGUINI SIAMETO LEMUNGUTI As personal representative(s) of SIAMETO OLE MUNGUTI deceased, HEREBY TRANSFER to KENEDY PARSIMEI OLE MUGUT

of P.O. BOX 55, NGONG being the person(s) entitled thereto under the will (or on the intestacy) of the deceased) the interest of the deceased comprised in the above mentioned title.

The Transferees declare that they hold that interest as proprietors in common in the following undivided shares:-

for as joint Proprietors

Dated this day of 20

Signed by the Transferor(s) In the presence of -



ID/NO. 6152543 PIN No. A005881210G Signature



ID/NO. 0199974 PIN No. A006346369F Signature

Signed by the Transferees In the presence of -

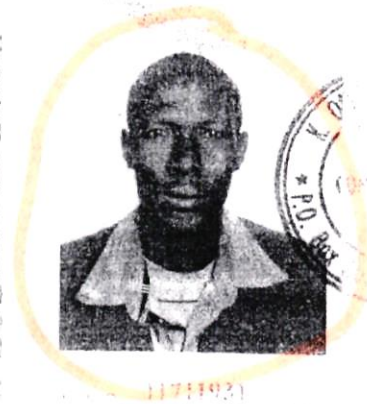

ID/NO. 1171193 PIN No. A006346369F Signature

20



Date received for registration Presentation Book Registration Fees
20..... No 19..... paid Receipt No

R 17

REPUBLIC OF KENYA

THE REGISTERED LAND ACT 1963
(Cap 300)

TRANSFER BY PERSONAL REPRESENTATIVE TO PERSON
ENTITLED UNDER A WILL OR ON AN INTESTACY

TITLE NO: **KAJIADO/ NGONG/ NGONG/ 58287**

I/WE **RESIATO MUNGUTI AND KAGUINI SIAMETO LEMUNGUTI**
As personal representative(s) of **SIAMETO OLE MUNGUTI**
deceased **HEREBY TRANSFER** to **KAGUINI SIAMETO LEMUNGUTI**

of **P.O. BOX 55, NGONG**
being the person(s) entitled thereto under the will (or on the intestacy) of the deceased) the interest of the
deceased comprised in the above mentioned title.

The Transferees declare that they hold that interest as proprietors in common in the following
undivided shares:-

(for as joint Proprietors)

Dated this day of 20.....

Signed by the Transferor(s)
In the presence of -



ID/NO. **6152543**
PIN No. **A005881210G**
Signature



ID/NO. **0199974**
PIN No. **A006346369F**
Signature

Signed by the Transferees(s)
In the presence of -



PIN No. **A006346369F**
Signature





Date received for registration No. 20 Presentation Book No. 19 Registration Fees paid Receipt No.

R.1.7

REPUBLIC OF KENYA

THE REGISTERED LAND ACT 1963 (Cap 300)

TRANSFER BY PERSONAL REPRESENTATIVE TO PERSON ENTITLED UNDER A WILL OR ON AN INTESTACY

TITLE NO: KAJIADO/NGONG/ NGONG / 58289

I/WE RESIATO MUNGUTI AND KAGUINI SIAMETO LEMUNGUTI As personal representative(s) of SIAMETO OLE MUNGUTI deceased, HEREBY TRANSFER to JOSPHAT SARUNI OLE MUNGUTI

of P.O. BOX 55, NGONG being the person(s) entitled thereto under the will (or on the intestacy) of the deceased) the interest of the deceased comprised in the above mentioned title.

The Transferees declare that they hold that interest as proprietors in common in the following undivided shares:-

For as joint proprietors

Dated this day of 20

Signed by the Transferor(s) in the presence of:



ID NO. 6152543 PIN No. A005881210C Signature



ID NO. 0199974 PIN No. 000348303 Signature

Signed by the Transferee(s) in the presence of:



ID NO. 00250121232 Signature





Date received for registration 20/01/2019 Presentation Book No. 19 Registration Fees paid Receipt No.

R. 1. 7

REPUBLIC OF KENYA

THE REG[STERED LAND ACT 1963 (Cap.300)

TRANSFER BY PERSONAL REPRESENTATIVE TO PERSON ENTITLED UNDER A WILL OR ON AN INTESTACY

TITLE NO: KAJIADO/ NGONG/ NGONG / 58290

I/WE RESIATO MUNGUTI AND KAGUINI SIAMETO LEMUNGUTI As personal representative(s) of SIAMETO OLE MUNGUTI deceased HEREBY TRANSFER to SAMUEL KUSEYO MUNGUTI

of P.O. BOX 55, NGONG being the person(s) entitled thereto under the will (or on the intestacy) of the deceased) the interest of the deceased comprised in the above mentioned title.

The Transferees declare that they hold that interest as proprietors in common in the following undivided shares :-

For as Joint Proprietors

Dated this day of

Signed by the Transferor(s) In the presence of



ID/NO. 6152543 PIN No. A0058812100 Signature



ID/NO. 0199974 PIN No. A0063463691 Signature

Signed by the Transferees(s) In the presence of



ID/NO. PIN No. Signature

031



Date received for registration 20 Presentation Book No Registration Fees 19 paid Receipt No

R.L.7

REPUBLIC OF KENYA

THE REGISTERED LAND ACT 1963
(Cap.300)

TRANSFER BY PERSONAL REPRESENTATIVE TO PERSON
ENTITLED UNDER A WILL OR ON AN INTESTACY

TITLE NO. **KAJIADO/ NGONG/ NGONG / 58291**

I/WE **RESIATO MUNGUTI AND KAGUINI SIAMETO LEMUNGUTI**
As personal representative(s) of **SIAMETO OLE MUNGUTI** deceased,
HEREBY TRANSFER to **BENSON LEMERIA OLE MUNGUTU**

of **P.O. BOX 55, NGONG**
being the person(s) entitled thereto under the will (or on the intestacy) of the deceased) the interest of the
deceased comprised in the above mentioned title.

The Transferees declare that they hold that interest as proprietors in common in the following
undivided shares:-

for as joint Proprietors)

Dated this day of 20

Signed by the Transferors
in the presence of -



ID/NO. **6152543**
PIN No. **A0058812100**
Signature



ID NO. **0199974**
PIN No. **A006346369F**
Signature

Signed by the Transferees
In the presence of -



ID/NO.
PIN No.
Signature

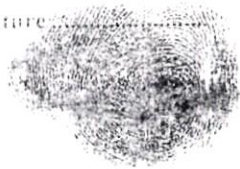

Date received for registration 29 No Presentation Book Registration Fees 19 paid Receipt No

R.L.7

REPUBLIC OF KENYA
THE REG[STERED LAND ACT 1963
(Cap 300)

TRANSFER BY PERSONAL REPRESENTATIVE TO PERSON
ENTITLED UNDER A WILL OR ON AN INTESTACY

TITLE NO: **KAJIADO/ NGONG/ NGONG/ 58295**

I/WE **RESIATO MUNGUTI AND KAGUINI SIAMETO LEMUNGUTI**
As personal representative(s) of **SIAMETO OLE MUNGUTI** deceased,
HEREBY TRANSFER to **CICILIA WAKECHO SIRONKA**

of **P.O. BOX 55, NGONG**
being the person(s) entitled thereto under the will (or on the intestacy) of the deceased) the interest of the
deceased comprised in the above mentioned title.

The Transferees declare that they hold that interest as proprietors in common in the following
undivided shares:-

for as joint Proprietor(s)

Dated this **19th** day of **October** 20**12**

Signed by the Transferor(s)
In the presence of:-



ID/NO. **6152543**
PIN No. **A005881210G**
Signature



ID/NO. **0199971**
PIN No. **A006**
Signature

Signed by the Transferees(s)
In the presence of:-



ID/NO. **12981623**
PIN No. **A007004610X**
Signature

11





REPUBLIC OF KENYA

THE REGISTERED LAND ACT
(Chapter 300)

Title Deed

MLS/TD/02/A2/02

No. 0118798



REPUBLIC OF KENYA

THE REGISTERED LAND ACT
(Chapter 300)

Title Deed

Title Number NGONG/NGONG/58294

Approximate Area 0.80 HA

Registry Map Sheet No. 148/3/8/SE & 148/3/13 NE

This is to certify that CICILIA WAKECHO SIRONKA

ID. NO. 12981623 P. O. BOX 55 NGONG HILLS.

is (are) now registered as the absolute proprietor(s) of the land comprised in the above-mentioned title, subject to the entries in the register relating to the land and to such of the overriding interests set out in section 30 of the Registered Land Act as may for the time being subsist and affect the land.

GIVEN under my hand and the seal of the

KAJIADO NORTH District Land Registry

this 30TH day of OCTOBER 2012



R. K. Kyalama 072

Date received for registration No. Presentation Book No. Registration Fees paid Receipt No.

R.I.7

REPUBLIC OF KENYA
THE REGISTERED LAND ACT 1963
(Cap 300)

TRANSFER BY PERSONAL REPRESENTATIVE TO PERSON
ENTITLED UNDER A WILL OR ON AN INTESTACY

TITLE NO: **KAJIADO/ NGONG/ NGONG / 58295**

I/WE **RESIATO MUNGUTI AND KAGUINI SIAMETO LEMUNGUTI** deceased.
As personal representative(s) of **SIAMETO OLE MUNGUTI**
HEREBY TRANSFER to **MONGA OLE MUNKUTI**

of **P.O. BOX 55, NGONG**
being the person(s) entitled thereto under the will (or on the intestacy) of the deceased) the interest of the
deceased comprised in the above mentioned title.

The Transferees declare that they hold that interest as proprietors in common in the following
undivided shares: -

as joint interest

Dated this day of

Signed by the Transferor(s)
In the presence of -



ID NO. 6152543
PIN No. A0058812100
Signature



ID NO. B1000
PIN No. A006346369F
Signature

Signed by the Transferees(s)
In the presence of -



ID No. B1000
PIN No. A0058812100
Signature



44



Date received for registration Presentation Book Registration Fees
..... 20 No 19 paid Receipt No

R.L.7

REPUBLIC OF KENYA
.....
THE REG[STERED LAND ACT 1963
(Cap 300)

TRANSFER BY PERSONAL REPRESENTATIVE TO PERSON
ENTITLED UNDER A WILL OR ON AN INTESTACY

TITLE NO: **KAJILADO/NGONG/NGONG/..58296.....**

I/WE **RESIATO MUNGUTI AND KAGUINI SIAMETO LEMUNGUTI**
As personal representative(s) of **SIAMETO OLE MUNGUTI** deceased,
HEREBY TRANSFER to **KUYAN OLE SIAMITO MUNGUTI**

of **P.O. BOX 55, NGONG**
being the person(s) entitled thereto under the will (or on the intestacy) of the deceased) the interest of the
deceased comprised in the above mentioned title.

The Transferees declare that they hold that interest as proprietors in common in the following
undivided shares -

[or as joint Proprietors]

Dated this day of 20

Signed by the Transferor(s)
In the presence of -



ID/NO. **5152543**
PIN No. **A005881210G**
Signature



ID/NO. **0199974**
PIN No. **A006346369F**
Signature

Signed by the Transferees(s)
in the presence of -



ID/NO. **24967533**
PIN No. **A0058812583**
Signature

12

1 2 3 4 5 6 7 8 9 10 11 12 13 14 15 16 17 18 19 20 21 22 23 24 25 26 27 28 29 30 31 32 33 34 35 36 37 38 39 40 41 42 43 44 45 46 47 48 49 50 51 52 53 54 55 56 57 58 59 60 61 62 63 64 65 66 67 68 69 70 71 72 73 74 75 76 77 78 79 80 81 82 83 84 85 86 87 88 89 90 91 92 93 94 95 96 97 98 99 100



Date received for registration Presentation Book Registration Fees
No. 20 No. 19 paid Receipt No.

R 1.7

REPUBLIC OF KENYA

THE REGISTERED LAND ACT 1963
(Cap 300)

**TRANSFER BY PERSONAL REPRESENTATIVE TO PERSON
ENTITLED UNDER A WILL OR ON AN INTESTACY**

TITLE NO: **KAJIADO/ NGONG/ NGONG / 58297**

I/WE **RESIATO MUNGUTI AND KAGUINI SIAMETO LEMUNGUTI**
As personal representative(s) of **SIAMETO OLE MUNGUTI** deceased.
HEREBY TRANSFER to **LEMUKUTI OLE NAISENEA**

of **P.O. BOX 55, NGONG**
being the person(s) entitled thereto under the will (or on the intestacy) of the deceased) the interest of the
deceased comprised in the above mentioned title.

The Transferees declare that they hold that interest as proprietors in common in the following
undivided shares:--

for as joint Proprietors

Dated this day of 20

Signed by the Transferors
In the presence of -



ID/NO. 6152543
PIN No. A005881210G
Signature



ID/NO. 0199974
PIN No. A006246269E
Signature

Signed by the Transferees
In the presence of -

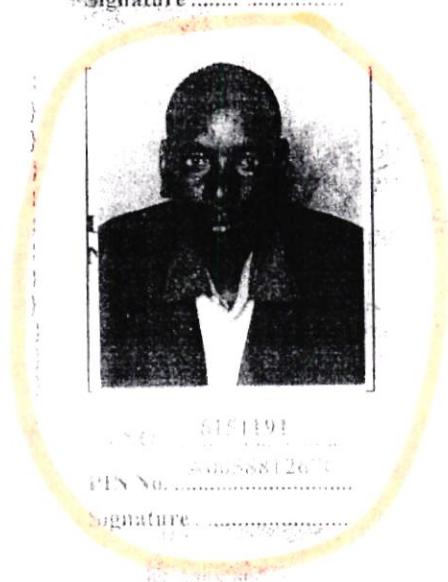

ID/NO. 0151191
PIN No. A005881210G
Signature

131



Date received for registration No. Presentation Book No. Registration Fees paid Receipt No.

R.L.7

REPUBLIC OF KENYA

THE REGISTERED LAND ACT 1963 (Cap 300)

TRANSFER BY PERSONAL REPRESENTATIVE TO PERSON ENTITLED UNDER A WILL OR ON AN INTESTACY

TITLE NO. KAJIADO/ NGONG/ NGONG / 58298

I/WE RESIATO MUNGUTI AND KAGUINI SIAMETO LEMUNGUTI

As personal representative(s) of SIAMETO OLE MUNGUTI deceased HEREBY TRANSFER to RESIATO ENE MUNKUTI

of P.O. BOX 55, NGONG

being the person(s) entitled thereto under the will (or on the intestacy) of the deceased) the interest of the deceased comprised in the above mentioned title.

The Transferees declare that they hold that interest as proprietors in common in the following undivided shares

for as set out Properties

Dated this day of 20

Signed by the Transferees in the presence of



ID No. 0152543 PIN No. A005881210G



ID No. 0199974 PIN No. A006240369F

Signed by the Transferees in the presence of



ID No. PIN No.

10



20 AUG 2014



Resiatio ene Munguti
Noongipa ene Munguti
P.O Box 55, Narok

29/07/2014

Hon. Justice Mutunga
President of the Supreme Court
Nairobi

Mr. Keriako Tobiko
Director of Public Prosecutions
NSSF Building – Block ‘A’
19th Floor
P.O Box 30701-00100
Nairobi, Kenya



Kenya Anti-Corruption Agency
Nairobi, Kenya

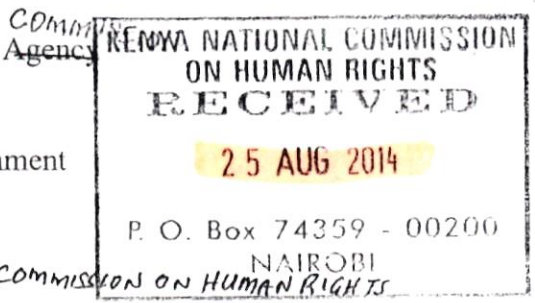

Kajiado County Government
P.O Box 11
Kajiado Town

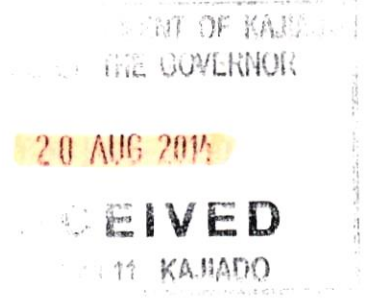



COMMISSION
KENYA NATIONAL COMMISSION ON HUMAN RIGHTS
NAIROBI, KENYA

RE: PETITION TO INVESTIGATE THE 35 YEARS OF CRIMINAL INTEREFENCE IN THE MATTER OF THE ESTATE OF THE LATE SIAMETO MUNGUTI

The Judiciary, the Director of Public Prosecutions, the Kenya Anti-Corruption Commission of Kenya and the Kajiado County Government are hereby requested to investigate how a group of 49 individuals land grabbers as listed in one document attached herewith worked in cahoots with Kajiado land registry officials have perfected impunity in succession of the estate of Siameto ole Munguti. The group of 49 believed in the power of money to ride roughshod on us. They viewed us as poor and helpless but the justice has prevailed at the law courts, yet they are still determined to subvert it through the three case filed at the High Court in 2013. We take the three cases as illegal harassment and intimidation although two of them have already been thrown out by the Constitutional Court (cause No. 154) and the Environment and Land Court (cause No.542). *FORTY YEARS, SINCE MUNGUTI DIED, OF CLADESTINE INTERMEDDLING WITH OUR PROPERTY RIGHTS BY KAJIADO LAND REGISTRY OFFICIALS TO BE CHECKED*

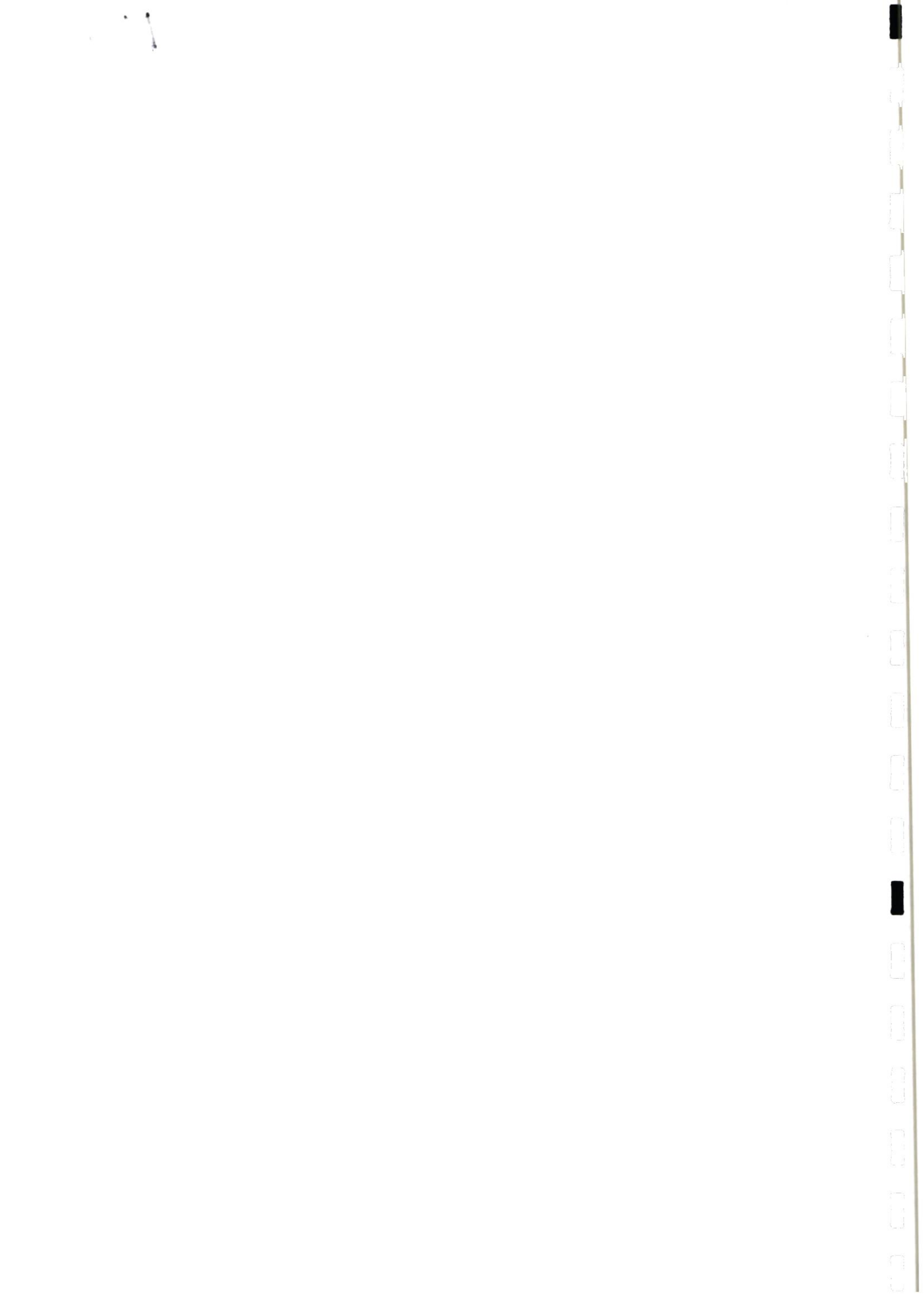
A group of 49 people led by Athman Salim Mohamed exhausted their options of criminal interference with succession of Siameto Munguti when the more than ten court cases instigated by their actions were concluded in 2010. For the last 35 years, the group has sponsored many illegal activities that were meant to disinherit us by first ensuring that we were physically thrown out of our land through violence.



REFERENCE CARD
 The Judiciary
 Office of the Ombudsman

Follow-up Ticket No.: **1017506**
 Case No./Complaint:
 Parties:

Judiciary Ombudsman | Supreme Court of Kenya
 P.O Box 30041 - 00100, Nairobi. Tel: 020-2221221 Ext 032/194/150
 servicedesk@judiciary.go.ke



KENYATTA NATIONAL HOSPITAL
 P.O BQX 20723 -00202
 NAIROBI, KENYA
 TEL: +254 202726300-9
 EMAIL: KNHADM@KNH.OR.KE
 WEBSITE: WWW.KNH.OR.KE

SUMMARISED INTERIM INVOICE

PAYER :	INVOICE NO.: 80382
SCHEME NAME :-	PATIENT NO: 0195708
MEMBER NO. :-	PATIENT NAME: LEDAMA EMANUEL
MEMBER NAME:	WARD: LEVEL 7 WARD 7B
ED NO. :-	DOCTOR: DR. RESIDENT DOCTOR
ADM DATE: 2014-06-16	DISCHARGE DATE: -

DESCRIPTION	QTY	AMOUNT	BALANCE KSH
	93	50,800.00	50,800.00
BED CHARGES- MEDICINE	1	700.00	51,500.00
GENERAL X-RAY FEE	3	3,350.00	54,850.00
LAB FEE -HAEMATOLOGY / BTU	19	8,500.00	63,350.00
NURITION FEES	3	300.00	63,650.00
NURSING- ACCIDENT & EMERGENCY	1036	15,100.00	78,750.00
NURSING- MEDICINE	449	7,190.00	85,940.00
PHARMACY FEE	2	1,150.00	87,090.00
PHYSIOTHERAPY FEE	1	15.00	87,105.00
SALE OF THEATRE CONSUMABLES		1,500.00	1,500.00
INVOICE AMOUNT			1,500.00
TOTAL Medicine Services Fee			85,605.00
TOTAL RECEIPTS			
NET AMOUNT			

PRINTED BY : CAROLYNE OBIERO
SIGNATURE : 

PRINT DATE : 31-7-2014

STATEMENT

90:



26 AUG 2014

CECILIA WAKESHO SIRONKA
P.O.BOX 55
NAROK
TEI: 0714377660

26/8/2014

HON JUSTICE MUTUNGA
PRESIDENT OF SUPREME COURT
NAIROBI.

RE: MILIMANI COMMERCIAL MAGISTRATE'S COURT:- CASE NO. 123 OF 2006

VERSUS

SUCCESSION OF SIAMETO MUNGUTI SUCCESSION CAUSE HCC 2395 OF 2003
[HCC.227 OF 80 and COURT OF APPEAL 272 of 2002]

I am an interested party as widow of Michael Sironka Munguti who has been suing on behalf of the families of Resiato and Noongipa. At the same time I hold title Ngong/Ngong/58294 which I am unable to benefit from because of what I consider as criminal interference by Athman Salim Mohamed and 48 others, first indirectly (case 123 of 2006) and of late directly by filling three consecutive cases which I have listed below.

My son is receiving kidney treatment at Kenyatta National Hospital where he is waiting for availability of funds and a donor for a transplant. I urgently need money from my share of this property for my son's treatment.

In this regard, I petition you to examine Milimani Commercial COURT ORDER NO. 123 of 2006 and see how it was used by Kajiado district Land registrar at the behest of Athman Salim Mohamed and 48 others in removal of HIGH COURT ORDERS that were entered in the following GREEN CARDS, Ngong/Ngong/ 20319, 20320, 20321, 20322, 20323, 20324, **23746, 28747 and 23748** and take appropriate action.

Athman Salim Mohamed and 48 others are using criminal effects of COURT ORDER 123 of 2006 to base their three cases' defective affidavits viz Constitutional Court 154 of 2013, ELC 432 of 2015 and Succession Cause HCC 2395 of 2003 and another application through Simon Munguti to nullify succession cause HCC 2395 of 2003. Nepruko, Simon's mother application to nullify the same was dismissed by Hon. Justice Dulu in 2006.

Athman and Mulwa applied to the High Court in Constitutional Court 154 of 2013 to be allowed to serve us through the STANDARD NEWSPAPERS but also deny having read our CAVEAT EMPTOR in the NATION NEWSPAPERS dated November 2007. The duo should be censured for attempted engagement in double standards.

When Ngong/Ngong/20321 was illegally subdivided by Nepruko, the resultant parcels of land Ngong/Ngong/23746, 23747 and 23748 were supposed to show entries of cautions of Sironka Munguti as a beneficiary and those of High Court 227 of 80. With exception of

CH



Ngong/Ngong/23746, the entries were omitted on GREEN CARDS for (Ngong/Ngong/23748) **for Athman Mohamed and (Ngong/Ngong/23747) for Wilfred Kyalo Mulwa**. The two conspired with the land registrar to omit the entries in respective GREEN CARDS that were filed in their case against the family of Resiato and Noongipa Munguti.

I attach herewith the documents that can be used in interrogating the affidavits of Athman Salim and 48 others. Please expedite the matters as we have suffered for a long time under this group of people.

Cicilia Wakesho Sironka. *CSUA*

Beneficiary

• • •
• • •



MOGIRE & CO.

ADVOCATES AND COMMISSIONER FOR OATHS

COMMERCE HOUSE
2ND FLOOR, ROOM 203
MOI AVENUE
P.O. BOX 60381
NAIROBI, KENYA
TEL. (02) 313551

K. Mogire LLB (Hons) NBI Dip KSL

11th October, 2012

OUR REF: KM413\12

THE GENERAL MANAGER
KENYA POWER & LIGHTING CO. LTD
STIMA PLAZA, KOLOBOT ROAD
OFF LIMURU ROAD
P.O BOX 30177-00100
NAIROBI.



Dear Sir,

**RE: ILLEGAL CONNECTION OF POWER ON NGONG/NGONG/27
AND DEMAND FOR DISCONNECTION**

We have been retained by our clients who are the following:

- (1) KAGUINI SIAMETO LEMUNGUTI
- (2) PATRICK SIMIREN MUNGUTI
- (3) MICHEAL SIRONKA MUNGUTI
- (4) KENNEDY PARSIMEI MUNGUTI
- (5) BENSON LEMERIA MUNGUTI
- (6) SAMUEL KUSEO MUNGUTI
- (7) JOSPHAT SARUNI MUNGUTI
- (8) RESIATO MUNGUTI
- (9) KESWE MUNGUTI
- (10) MONGA MUNGUTI
- (11) KOYAN MUNGUTI
- (12) MURIITHI MUGO
- (13) MOSES NDEGWA GITONGA

Our client are the beneficiaries of Title No. Ngong/Ngong/27 pursuant to the Certificate of confirmation of Grant for which copy is attached for your ease of reference.

However following a fraudulent transfer and subdivision of Title No. Ngong/Ngong/27 into several plots namely :

Ngong/Ngong/37710,37711,37398,37399,37400,46888,46889,46890,46891,46892,46893,46894,46895,46896,46897,46898,46899,43265,43266,43267,43268,43269,43270,47290,47291,43272,39398,39399,39400,39401,39402,39403,39404,39405,39406,39407,38277,41752,41753,41754,41755,41756,39204,39205,38317,38318,43068,43069,40286,37849,46975,46976,6977,37851,37107,23747,23748,42556,42557,42558,42694,42695,42560,

Received

6.11.2012

Jw 16/66

*Tona Owade
Marketing Officer
2:50 PM*

Longa Office

11



42561,42562,42017,41785,38313,38314,35976,35977,42132,42133,42134,42135,42136, 42137,42138,42139,42140,42141,42142,42143,42144,42145,42146,42147,42148,42149, 42150,42151,42152 & 42153 some persons did apply and were supplied with electricity and your company proceeded and erected poles on the land. Note that any power line on these parcels of land are illegal.

The said subdivisions and tiles have been cancelled by the High Court in Nairobi and the same was confirmed by the High Court in Nairobi and the same was confirmed by the Court of Appeal. In the circumstances the electricity poles and power lines running over our clients' parcels of land are not only illegal but amount to trespass unto our client's parcels of land.

We do have instructions to demand that you do proceed to immediately disconnect power running on our clients' aforesaid parcel of lands and remove altogether the poles erected on the land as our clients do not have use of the same for the time being.

TAKE NOTICE that unless you do comply to disconnect and remove the poles and power line wires running on our clients' respective parcels of land within thirty (30) days from the date hereof, our strict and mandatory instructions are to seek appropriate legal redress at your own risk as to costs and consequences thereof.

Yours faithfully,

Encls.

Cc: Client

**Cc. AREA MANAGER
KENYA POWER & LIGHTING CO. LTD
ONGATA RONGAI/NGONG**

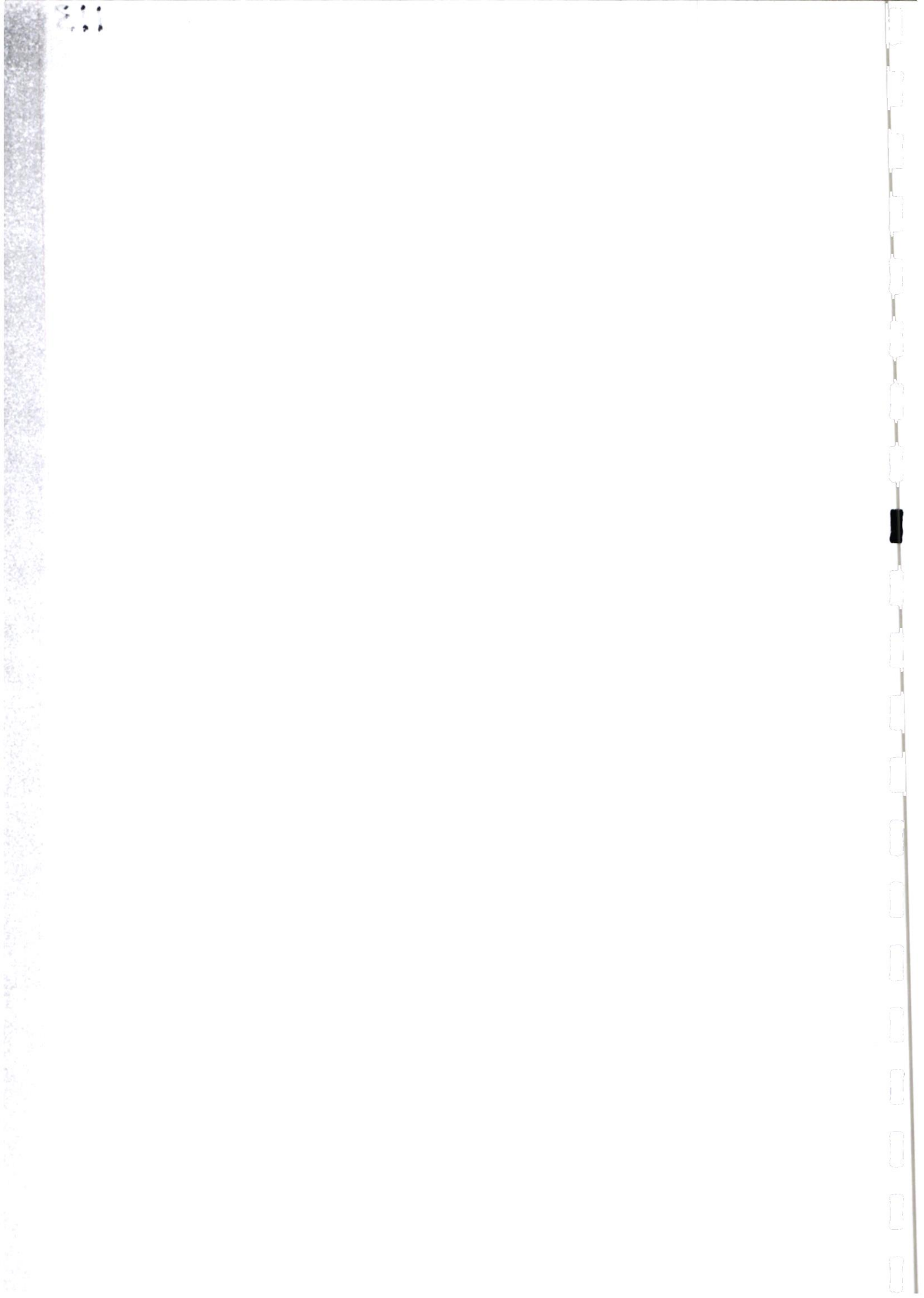

RESIATO ENE MUNGUTI
NOONGIPA ENE MUNGUTI
P.O.BOX 75
NGONG, KAJIADO

18/6/2014

HON. NKEDIANYE
KAJIADO COUNTY GOVERNOR
P.O.BOX 11
KAJIADO



Dear Sir,

RE: REQUEST FOR DEMOLITION OF ILLEGAL STRUCTURES ON OUR LAND
L/R NO. KAJIADO/NGONG/NGONG/58286-58298 ALL AT KIBIKO, NGONG

We are the registered owners of the following parcels of land

- KENNEDY PARSIMEI MUNGUTI.....NGONG/NGONG/58286
- NOONGIPA ENE MUNGUTI.....NGONG/NGONG/58287
- SARUNI MUNGUTI.....NGONG/NGONG/58289
- KUSEO MUNGUTI.....NGONG/NGONG/58290
- LEMERIA MUNGUTI.....NGONG/NGONG/58291
- SIMIREN MUNGUTI.....NGONG/NGONG/58292
- **WAKESHO SIRONKA MUNGUTI.....NGONG/NGONG/58294**
- MONGA MUNGUTI.....NGONG/NGONG/58295
- KOYANI MUNGUTI.....NGONG/NGONG/58296
- NAISENEA LEMUNGUTI.....NGONG/NGONG/58297
- RESIATO ENE MUNGUTI.....NGONG/NGONG/58298

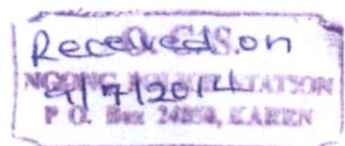
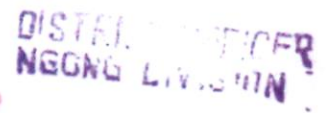

Photocopies of some titles and mutation survey form are attached for ease of reference.

We had family court cases and the ruling was in our favour. Unfortunately the court proceedings took long to finalize such that strangers invaded our land without permission and erected illegal structures.

We are old and sickly and our two sons, Sironka and Simiren passed on leaving two widows and many children. One of Sironka's children (ten year old) is admitted at Kenyatta National Hospital awaiting kidney transplant when a donor and money become available. And thus the urgent appeal for help from your good office. (We enclosed one photograph herewith)

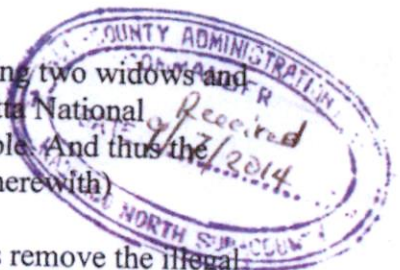

In this regard, we earnestly appeal to your COUNTY INSPECTOR to help us remove the illegal structures from our land since we really want to develop to alleviate our families' financial problems.

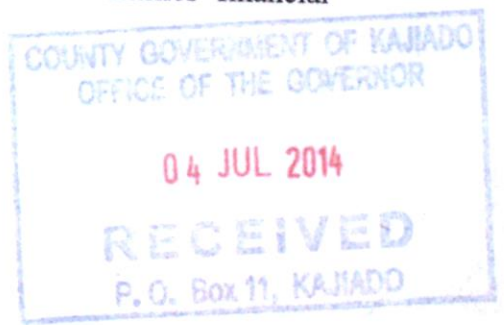

10

10
11
12
13
14
15
16
17
18
19
20
21
22
23
24
25
26
27
28
29
30
31
32
33
34
35
36
37
38
39
40
41
42
43
44
45
46
47
48
49
50
51
52
53
54
55
56
57
58
59
60
61
62
63
64
65
66
67
68
69
70
71
72
73
74
75
76
77
78
79
80
81
82
83
84
85
86
87
88
89
90
91
92
93
94
95
96
97
98
99
100

Noongipa ene Munguti

CC.

- Minister for Lands & Housing, Kajiado County
- County Inspector, Kajiado County
- Enforcement Officer, Kajiado County
- Enforcement Officer, Ngong Sub-county,
- Member County Assembly, Ngong
- OCPD – Ngong
- OCS – Ngong
- D.O Ngong
- Chief, Kibiko.

22



Resiato ene Munguti
Noongipa ene Munguti
P.O Box 55, Narok

19/11/2014

Hon. Justice Mutunga
President of the Supreme Court
Nairobi
Dear Sir

**SUCCESSION OF THE LATE SIAMETO MUNGUTI:- CASES KAJIADO SENIOR RESIDENT
MAGISTRATE COURT SRM 4/1999, HCC 227/80, COURT OF APPEAL CAUSE 272 OF 2002, HCC
2395 OF 2003, MILIMANI COMMERCIAL COURT CAUSE SRM 123 OF 2006, KIBERA
MAGISTRATE'S CRIMINAL COURT CASE 3576 OF 2007, ORDER OF MANDAMUS CERTIORARI
HCCC30 OF 2010,**

**CONSTITUTIONAL & HUMAN RIGHTS COURT 154 OF 2013, ELC, NAIROBI 432 OF 2013 AND
SUCCESSION CAUSE HCC 2395 OF 2003(REVISITED IN 2014 WITH THREE NEW PETITIONS)**

We refer to your reply letter ref. 15/1 VOL.XII dated letter 24th November, 2003. We also sought an opinion from the Law Society of Kenya on additional adverse issues, which is given vide letter ref.M3 dated 3.6.08. The adverse issues have escalated since we do not have money to pursue the matters either through the courts or the police. We have appeared in all Judiciary open days since times of Justice Gicheru to plead for fast tracking of cases and fairness without success.

The family of the late Siameto once again kindly requests the Chief Justice to investigate members of the bar, the bench and Kajiado District Land Registrar in respect of vested interests in the estate of the late Siameto Munguti which has rendered the three widows and their respective children destitute. Please, establish whether the three advocates, Githu Muigai, I.S.Nyamberi and George Oraro have been bleaching the moral and ethics standards of legal practice while individually representing Nepruko Munguti in her succession war with her co-wives.

1. I.S. NYAMBERI OF OMWOYO, MOMANYI AND COMPANY ADVOCATES

**FRAUDULENT COURT ORDER: - MILIMANI COMMERCIAL COURT SRM 123 OF 2006,
MAGISTRATE E.K. CHERONO**

We request advocate I.S.Nyamberi investigated for making fraudulent Court Order: - Milimani Commercial Order SRM 123 of 2006. Documents have been filed to show how he cleverly sneaked the fraudulent junior magistrate's court order 123 of 2006 to undermine the authority

11



of High Court of Kenya as seen in succession cause 227/80, 2395 of 2003 and Court of Appeal 272 of 2002.

- Certified copy of GREEN CARD Ngong/Ngong/23746 are clear as to who registered the cautions
- The official search for Ngong/Ngong/23746 which was presented to the land control board clearly "**Court Order:- No dealing until succession cause No. 227 of 1980 is finalized at the High Court of Kenya**"
- In this case, Nyamberi seems to act for both plaintiff and respondent
- The copies of application to Oloolaiser land control board and corresponding CONSENT to transfer bear no parcel number.
- The mutation survey forms used has no parcel number but nevertheless subdivision of a parcel of land occurred.
- The mutation survey was carried in the first week of November 2005 while the Commercial Court Order 123 of 2006 is dated 20th January 2006. The official search of Ngong/Ngong/23746 must have reflected entry No.7 dated 30.8.2004 on CTC of attached GREEN CARD.

This matter must be referred to the police and the Director of Public Prosecution to investigate and punish criminals. The intention was to create an opportunity to vandalize and loot our property.

2. **TRUMPED UP CRIMINAL CHARGE AT KIBERA LAW COURT CC 3576 OF 2007**

The magistrate Joseph Karanja, the OCS Ngong Police Station and Kajiado district land registrar conspired with the purchasers (Athman Salim and 48 others) to harass Resiato and Noongipa through trumped up trespass charge on Ngong/Ngong/37848 at Kibera Law Court in SRM CCC 3576 of 2007, Republic –Vs- Patrick Simiren. Although Patrick Simiren planted trees on parcels of land Ngong/Ngong/23747, 27848, 3706 which belong to Athman Salim, Kyalo Mulwa, Ricard Obara Ondieki among other abuttals, he was charged with trespass on different parcels of land belonging to Nepruko Siameto and Sialo. However, Sialo's parcel Ngong/Ngong/38912 was later withdrawn on realization it was far from the parcels mentioned above.

It was sinister for the magistrate to refuse to recognize the ruling of Lady Justice Kalpana Rawal in HCC 227 of 80, Court of Appeal cause 272 of 2002 and confirmation of Grant 2395 of 2003 records.

The magistrate Joseph Karanja destroyed the evidence by returning the original title Ngong/Ngong/37848 to Nepruko to continue subdividing the suit land while he used CTC of title supplied by collusive district land registrar. I file mutation survey form which subdivided Ngong/Ngong/37848 into 40285 and 40286 on 23 July, 2007, see case dates in charge sheet. Somebody wrote the name of Nepruko instead of her usual thump printing.

Ngong/Ngong/40285 was subdivide into Ngong/Ngong/43068 and 43069 in 3rd August 2008



and this time a very sick Nepruko "thump printed" on the mutation survey form. She died on 27th August 2008.

Kibera Law Court magistrate was irrationally determined to jail Patrick Simiren but his ill-advised designs were stopped by application for the Order of Mandamus Certiorari which was granted by Lady Justice Nambuye as miscellaneous civil application HCCC 33 of 2010.

3. **KAJIADO DISTRICT LAND REGISTRAR**

At Kajiado land registry, illegal removal of cautions against titles is big business. Cautions are removed, the parcel of land is subdivided and some resultant portions are sold and the caution is reinstated on GREEN CARD of resultant parcel of land that retains the name of the owner. This works better when the bar and the bench collude to lend credence to the process as happened to the estate of Siameto Munguti since 1980. If the land registrar, Milimani Commercial Court and Kibera magistrates Courts did not interfere, succession of the late Siameto Munguti would have ended with nullification of HCC 227 of 80 in 2001.

I attach CTC of GREEN CARD for Oraro' clients Athman Salim Mohamed and Mulwa Kyalo, Ngong/Ngong/20321. On subdivision into three portions Ngong/Ngong/ 23746, 23747 and 23748, court orders were retained in Ngong/Ngong/23746. Athman Salim (Ngong/Ngong/23748) and Mulwa Kyalo (Ngong/Ngong/23747) worked with the registrar to omit court order entries on their green cards. That is why they declare in their affidavits they noticed nothing when they were transacting.

4. **Professor Githu Muigai of Mugai Mohammed & Co Advocates.**

Nepruko Paid initial legal fee from bank account at Karen, Nairobi that was left by Siameto on death in 1974. It quickly got exhausted and Nepruko was encouraged to illegally subdivide and sell portions of Ngong/Ngong/27 which formed the larger part of estate in succession. Some resultant parcels were transferred to relatives of Muigai to serve as part payment of his legal fee. I attach copies of green cards which had previously been certified as true copies of the original by Kajiado district land registrar.

- ✓ **Peter Martin Gichamba secured resultant parcel of land Ngong/Ngong/20324**
- ✓ **Andrew Gichamba Muigai of P.O Box 320, Kiambu was beneficiary of Ngong/Ngong/35977**
- ✓ While Githu Muigai pursued succession cases HCC 2395 of 2003 and Court of Appeal 272 of 2002, his client in corroboration with purchasers who included his two relatives

11



formed a clandestine group to finance Nepruko's legal fees in exchange for portions of the suit parcel of land. The group sponsored one of their own Ricard Obara Ondieki to swear a collusive affidavit to sue Nepruko in Milimani Commercial Magistrate's court 123 of 2006 to remove caution orders of the High Court. The magistrate E.K.Cheronu was to remove caution on Ngong/Ngong/ 23746 but the Court Order included Ngong/Ngong/20319, 20320, 20322, 20323 and 20324 which were not included in Obara's prayer. This order discriminatively retained cautions on Ngong/Ngong/23747 and 23748.

5. **ORARO AND COMPANY ADVOCATES**

Athman Salim Mohamed and 48 others and other persons who declined their names to be included in the list have funded Nepruko against Resiato and Noongipa Munguti. After failure to accomplish anything behind the scene, they have come out of the woods and filed three consecutive cases in attempt to sanitize their ill-gotten land. Their financing of Simon Munguti to appeal for revocation of HCC 2395 of 2003 when it was fourteen years late also seemed doomed.

The Athman Salim Mohamed group instructed Oraro & Company Advocates to masquerade their land grabbing antics and forgeries of documents as constitutional right entitlement to our property.

- The Constitution and Human Rights court rejected their **case 154 of 2013**.
- They tried luck in Environment and Land Court case **432 of 2013** and to their chagrin, it too was thrown out.
- Athman Salim Mohamed and group have filled affidavits in an attempt to revoke HCC **2395 of 2003**. It is strange for Athman group to appear a cool 14 years after Lady Justice Rawal cancelled and revoked any subsequent title(s) that could emanate from subdivision of Ngong/Ngong/27, one claims to have known of it in 2012 through letter by Kenya Power Ltd who are fellow transgressors.

This group has conveniently forgotten that Milimani Commercial Court 123 of 2006 which they are banking on to win the cases is their direct forgery. There is no High Court Judge who would entertain overthrowing of High Court by a subordinate magistrate's court.

Oraro and Company firm of advocates has come on board to handle the cases for the group. The only reason Oraro and Company advocates and their relatives have bought portions of land from the estate in suit. They have declined to have their names included on the list filed by Athman Salim and 48 others. **Lucas Odera Hajula I/D No. 0803021**, as seen on CTC of GREEN CARD Ngong/Ngong/42143 is a brother of advocate **H.C. Odera of Oraro & Company advocates**. In this regard, I attach a certified true copy of original GREEN CARD and a letter from Oraro & Company for ease of reference.

We came to court on 19th November, 2014 hoping see the end of the numerous cases after 40 years of family quarrel, most of them in the courts. However, we were surprised for senior

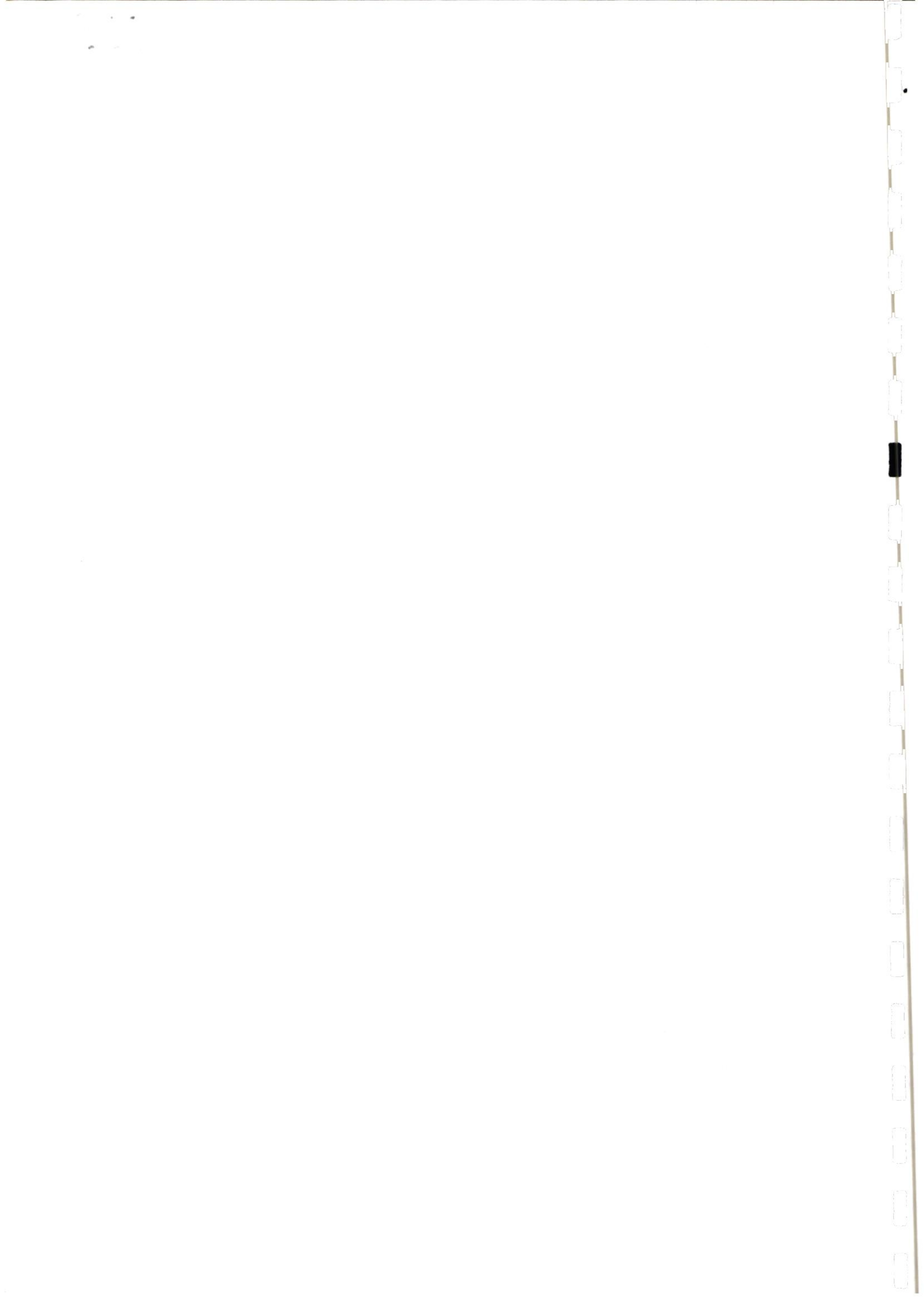

counsel Geogre Oraro to ask to be granted until 11th February 2015 to highlight issues. This was easily granted as if we did not exist or even matter which is not fair. He was also granted stay of execution of Lady Justice Nambuye's Order but his clients who include some of his staffs are still carrying out illegal activities on our land to outpace everything including courts, ourselves etc. I hope the court notices that and acts without asking poor people to move it by filing contempt proceedings. Is the era of judges acting without fear of intimidation and favours really over?

The courts have been treating our cases as if they started with 2395 of 2003. Siameto Munguti died in 1974 i.e. 40 years ago, and trouble started almost immediately. We have been trying family dispute resolution mechanism which was trashed by their client. It is unfortunate the court does take such records into consideration. That is why advocates have been harping that we came to court after 17 years late.

5(b) CONSOLIDATION OF CASES.

The request the Chief Justice to order that all cases become combined and settled once and for all. Athman Salim and Mulwa Kyalo have filed cases (a) Constitutional and Human Rights Court 154 of 2013 (b) Environment and Land Court 432 of 2013 (c) affidavits in 2395 of 2003 (d) Simon Munguti's affidavits in 2395 of 2003 is financed by Athman Salim and 48 others. These cases are treated as individuals in respective courts but the theme is grabbing our property through the courts. They have intimated that if they lose in 2395 of 2003, they will appeal through the Environment and Land Court 452 of 2013. Kibera criminal case was brought to succession cause 2395 of 2003 by Lady Justice Nambuye in miscellaneous application for Mandamus certiorari 33 of 2010. Milimani Commercial Court 123 of 2006 should also be brought to 2395 of 2003 file since has had the greatest adverse effect on our lives.

Finally, we state once again that we are in dire problems. Our grandson Emanuel Ledama Sironka, thirtenn years old son of the late Michael Sironka Munguti is listed at Kenyatta National Hospital for Kidney transplant. If you allow this simple case to go to February 2015 for highlighting only, we ask you to help us get money to treat Ledama while we wait for kidney transplant.

6. Naikuni, Ngaa, Mencha and Company -VS- Nyachio, Nyagaka and Co. Advocates

Drama was witnessed in Justice Musyoka's court through the mischief of Simon Munguti. He changed Naikuni, Ngaa, Mencha & Company with Eldoret town based law firm Messers Nyachiro, Nyagaka & Co. Advocates and without filing change of advocate notice. Both reported to court to represent Simon and the exchange was not good. In his usual mischief of Simon Munguti felt Eldoret was far and inconveniencing for us to serve.

Resiato Munguti

Cicilia Wakesho Sironka
Beneficiaries of estate of Siameto Munguti

10



REPUBLIC OF KENYA
IN THE HIGH COURT OF KENYA AT NAIROBI
(MILIMANI LAW COURTS)

HIGH COURT OF KENYA
CENTRAL REGISTRY
20 MAY 2013
CIVIL SIDE
NAIROBI

ELC NO. 432 OF 2013

IN THE MATTER OF : THE ESTATE OF SIAMETO OLE MUNGUTI
AND

IN THE MATTER OF : THE RIGHT TO FAIR HEARING, EQUALITY
BEFORE THE LAW AND RIGHT TO PROPERTY
AND

IN THE MATTER OF : CONTRAVENTION OF FUNDAMENTAL RIGHTS
AND FREEDOMS UNDER ARTICLES 27, 40 AND 50
OF THE CONSTITUTION
AND

IN THE MATTER OF : THE REGISTERED LAND ACT CAP. 300 LAWS OF
KENYA (NOW REPEALED)
AND

IN THE MATTER OF : SECTION 93 OF THE LAW OF SUCCESSION ACT,
CAP. 160 LAWS OF KENYA
AND

IN THE MATTER OF : ARTICLES 19, 21, 22, 23, 165, 258 AND 259 OF
THE CONSTITUTION

BETWEEN

ATHMAN SALIM MOHAMMED.....1ST PETITIONER
WILFRED MULWA KYALO.....2ND PETITIONER

VERSUS

RESIATO MUNGUTI and NOONGIPA MUNGUTI
sued as the Administrators of the ESTATE OF
SIAMETO OLE MUNGUTI.....1ST RESPONDENT
SIMON OLE MUNGUTI sued as the Administrator
of the Estate of NEPURKO MUNGUTI.....2ND RESPONDENT

ADVOCATES
JAMES PUBLIC
COMMISSIONERS FOR OATHS
20 MAY 2013
RECEIVED
Time 3:50p Signature [Signature]

Received under protest
→ Served late



KESWE OLE NGUTI Alias LEMUNKITI OLE
 NAISENEA.....
 MONGA OLE MUNGUTI alias MOONGA OLE
 MUNGUTI.....
 MICHAEL SIRONKA MUNGUTI Alias
 MICHAEL SIRONKA MUNKUTI.....
 KENNEDY PALSIMKEI OLE MUGOT Alias
 KENEY PARSIMEI OLE MUNGUTI.....
 BENSON LEMERIA OLE MUGOT alias
 BENSON LEMERIA OLE MUNKUTI.....
 REGISTRAR OLE LANDS, NGONG.....
 THE CHIEF, LANDS REGISTRAR.....
 THE ATTORNEY GENERAL.....

HIGH COURT OF KENYA
 CENTRAL REGISTER
 20 MAY 2018
 CIVIL
 NAIROBI

3RD RESPONDENT
 4TH RESPONDENT
 5TH RESPONDENT
 6TH RESPONDENT
 7TH RESPONDENT
 8TH RESPONDENT
 9TH RESPONDENT
 10TH RESPONDENT

REPLYING AFFIDAVIT

I, KENNEDY PARSIMEI OLE MUNGUTI residing at and of Post Office Box Number 55 Narok hereby make oath and state as follows:-

1. THAT I am the 6th respondent herein and as such, authorized to swear this affidavit.
2. THAT I am also a beneficiary coming from the house of Noongipa Munguti the 2nd Administrator herein.
3. THAT there are three Administrators and three houses in this Estate, Resiatio Munguti the 1st Administrator, Noongipa Munguti the 2nd Administrator and the late Nepruko Munguti now succeeded by Simon Munguti as the 3rd Administrator, between whom the Estate was shared equally in Succession Cause No. 2395 of 2003.
4. THAT to-date, only one house that of Nepruko Munguti the 3rd Administrator represented by Simon Munguti is with impunity enjoying the Estate.
5. THAT the 3rd Administrator has all along acted with impunity subdividing the property long after revocation of the Grant in P & A 227 of 1980. A chart with dates presented by him in Succession Cause No. 2395 of 2003 is annexed hereto and marked "KPO-1".

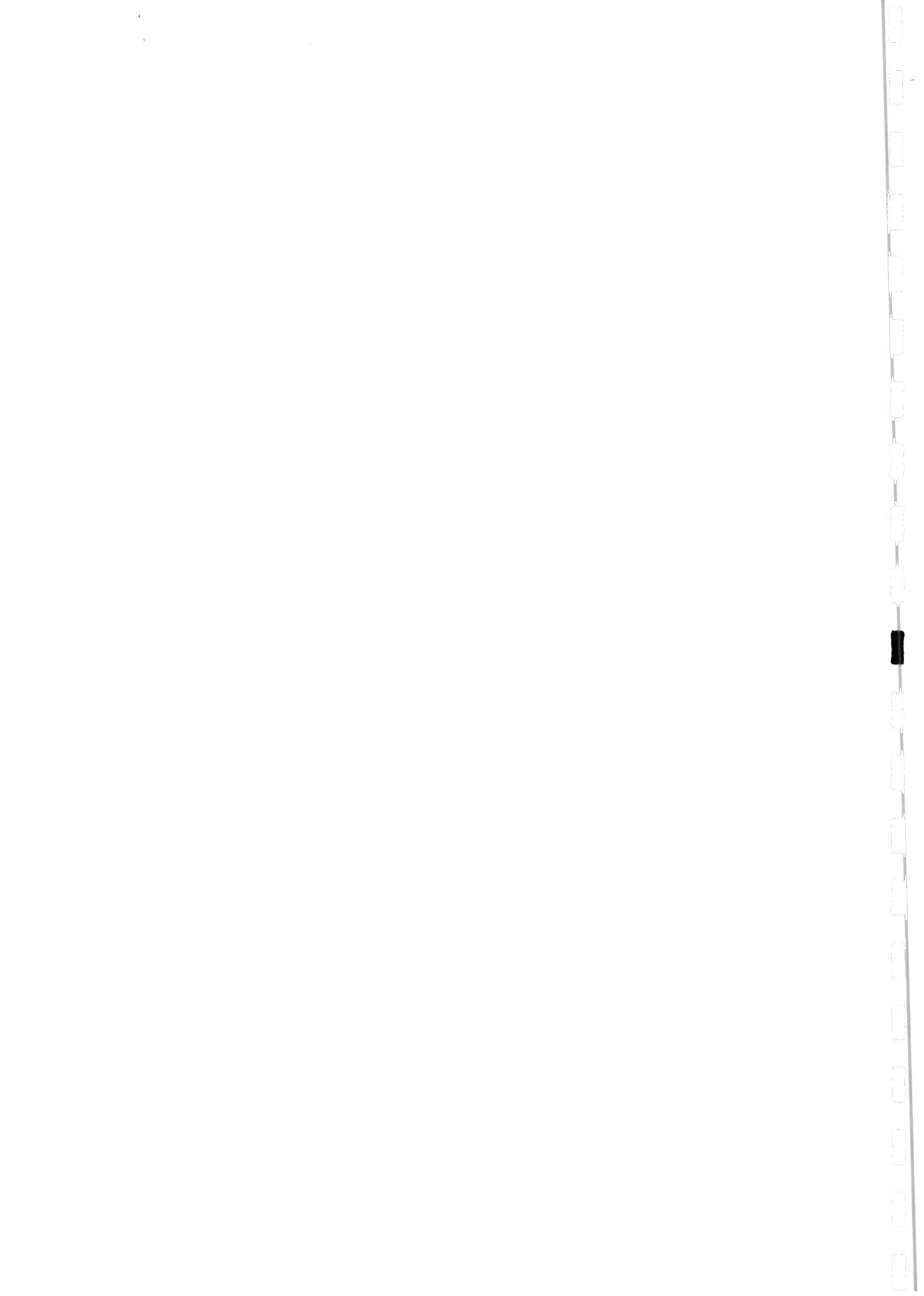

6. THAT as admitted by the Petitioners, the two parcels emanated from the Estate of Siameto Ole Munguti the subject matter in P & A 2395 of 2003.
7. THAT by revoking the Grant to Nepruko Munguti in P & A 227 of 1980 the court found the process through which she acquired the titles thereto flawed, putting the legitimacy of all transactions accruing therefrom in question.
8. THAT what is flawed in the provisions of the Law of Succession Act cannot be legitimate in the eyes of the Constitution and as such, not protected.
9. THAT the issue here is land, which is purely private right issue and not constitutional.
10. THAT in any event, the Family Court is aware of the Petitioners' presence on the Estate property.
11. THAT in Clause (viii) on page 3, Nambuye J. captures it as follows:-

"These three resulting parcels are registered in the name of Nepruko Siameto Munguti, Athman Salim Mohamed and Wilfred Mulwa".

12. THAT on page 12 of her ruling, Nambuye J. reckoned the problem the presence of these third party presents as follows:-

"That an issue arose when it came to actualize the distribution on the ground as it was discovered that the revoked Grant had brought on board third parties as beneficiaries of the Estate property and yet they were not beneficiaries to the detriment of the rightful beneficiaries, hence the need to have the subject property revert back into the name of the deceased so that distribution can be effected".



13. THAT on page 15 in Clause 8 of her ruling, exhibited by the Petitioner Nambuye J. reiterated that it is the duty of the court to actualize confirmation when she observed as follows:-

"It is trite law and this court has Judicial notice of the fact that where a court order confers a benefit, to a party, it is the business of that court to actualize that benefit to that party within its power and authority. The beneficiaries of the deceased subject of these proceedings are entitled to the actualization of their benefit as per the distribution in the confirmed Grant".

14. THAT the rulings of both Lady Justices Gacheche and Nambuye were merely facilitative and meant to set the stage for actualizing the benefit of distribution.

15. THAT distribution has been sabotaged by the 3rd respondent through numerous applications in court, refusal to cooperate and outright dishing out of the property of the Estate to outpace the court and other beneficiaries.

16. THAT recently, he has brought an application in P & A 2395 of 2003 questioning the ruling of Nambuye J. of 17th February, 2012 and among other things, seeking revocation of the Grant on account of acquisition of the Estate property by third parties, a complaint similarly raised by the Petitioners herein. A true copy of the said application is annexed hereto and marked "KPO-2".

17. THAT since this Petition is seeking a review of orders of the Family Court made with jurisdiction, it is only fair that it is be handled by the same Court.



18. THAT in any event, as set out by the Petitioners in their Petition, Section 93 of the Succession Act contemplates situations alleged by the Petitioners and the more reason why Family Court is the best suited.
19. THAT in any event, the issues herein emanate and intertwine with the practabilities of the distribution of the Estate in P & A 2395 of 2003 from which it cannot be divorced.
20. THAT the challenges of separating the shares of the three houses necessitates the collapsing of all the subdivisions first.
21. THAT thereafter, the Petitioners will still retain or in inherit their present locations from the entitlement of the third house of the late Nepruko Munguti.
22. THAT during the demarcation, the parcels of the two Petitioners together with about three more homes already settled on the property can be picked first, but credited to the 3rd Administrator's share.
23. THAT I verily believe the Family Court is better placed to handle the process as it is already alive to the peculiar challenges herein.
24. THAT this route is alluded to on page 10 of Justice Nambuye's ruling as follows:-

"Further that the Survey Map which had been received by them also annexed revealed a total of 34% of Land Parcel Number NGONG/NGONG/27 had been sold by Nepruko Munguti and to the dependants this should be adjudged as the share of the 3rd Administrator's house while the other portion should be left for the benefit of the other two Administrators houses."

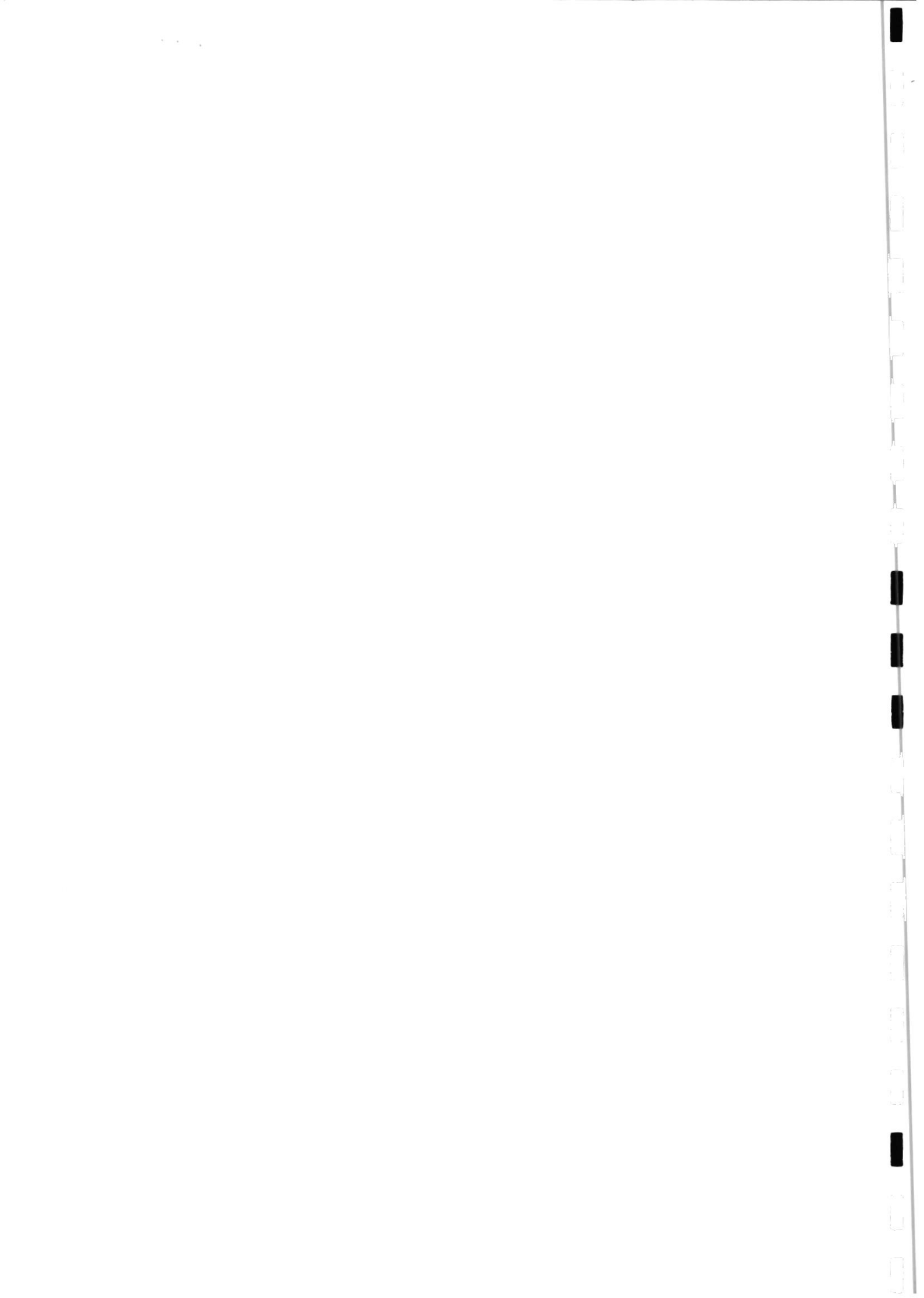

25. THAT the process is now scheduled to move to the next stage of demarcation and application for the Executive/Deputy Registrar to sign the Mutation Forms, Transmission etc on behalf of the 3rd Administrator is scheduled for hearing on 3rd July, 2013. A true copy of the application is annexed hereto and marked "KPO-3".
26. THAT the issue herein, which is land, is being wrongly disguised as Constitutional.
27. THAT I verily believe that this frenzy of litigation, particularly coming after the revocation of titles is meant to forestall the 3rd Administrator from accounting for his past misdeeds.
28. THAT at the present, despite sabotage from the 3rd Administrator, the 1st and 2nd Administrators are still working to assemble the Estate, to enable effective distribution.
29. THAT my brother Patrick Simiren was arrested and arraigned before a Kibera Court on trumped up charges of trespass in Kibera Criminal Case No. 3587 of 2007 – Republic –vs- Patrick Simiren Munguti. A true copy of the charge sheet is annexed hereto and marked "KPO-4".
30. THAT on some occasions, collusive orders have been given in lower court to remove restrictions placed by the High Court by advocates who have been party to the proceedings in the High Court. A true copy of one such order is annexed hereto and marked "KPO-5".
31. THAT the Petitioner's contention that they ought to have been heard before the orders by Nambuye J. is therefore preposterous and hasty, as we are not there yet – for **NGONG/NGONG/27** was to be set up first, together with a plenary for re-arrangement or resolution of all interests be it of the beneficiaries or third parties.

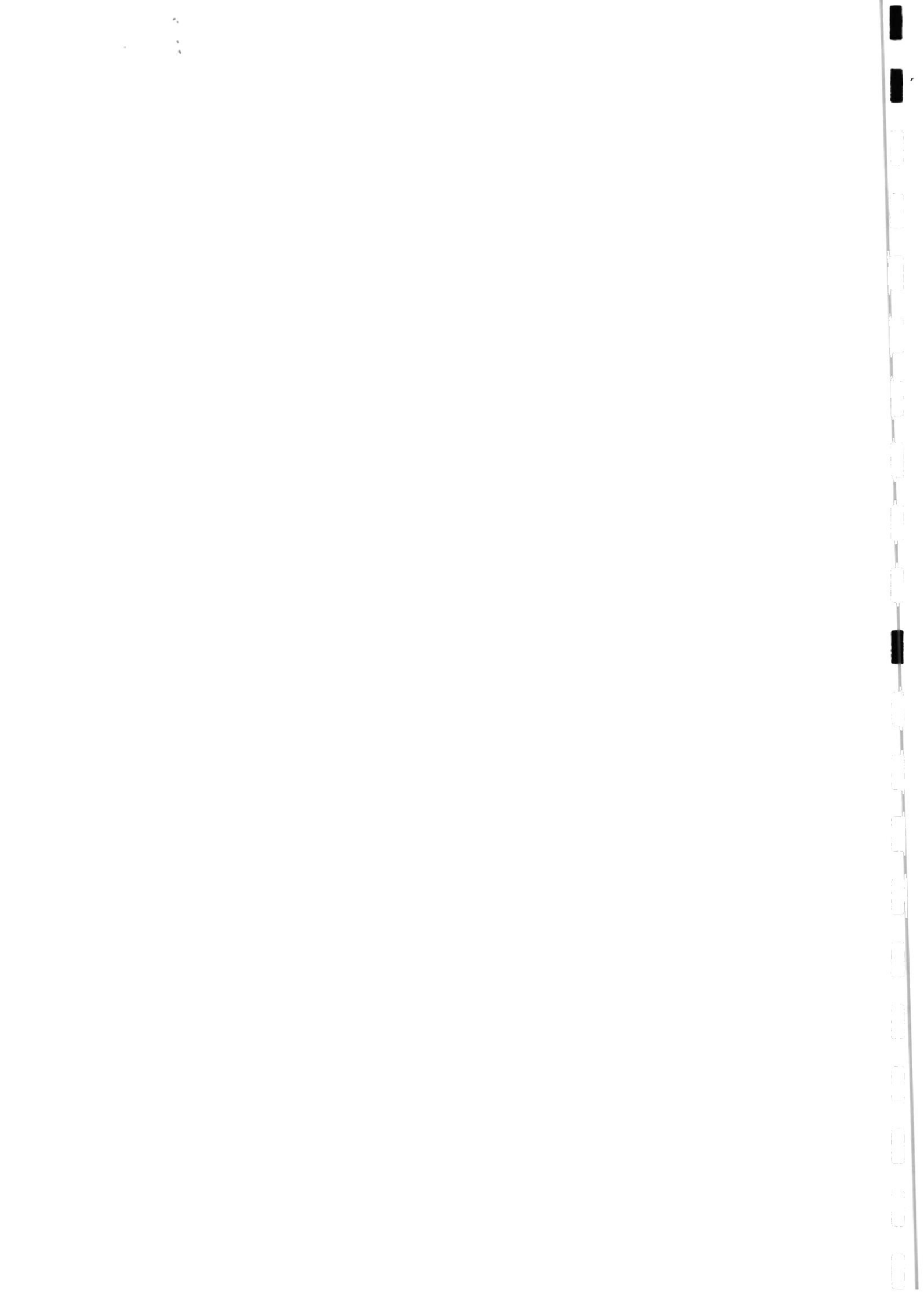

32. THAT the Petitioners' interest is about 1/2 an acre each, well within Simon Munguti's share of 33.3% and the Petitioners complaint being private between them and Simon Munguti should not interrupt the finalization of distribution.

33. THAT the Petitioners having bought from the 2nd Respondent herein, are his surrogates and this Petition is nothing but a set up, particularly if the Petitioners attempt a consent with the 2nd respondent, that is Simon Munguti the culprit with whom we have been mixed on the defensive side.

34. THAT in any event, the Petitioners appear to have named only less than half the beneficiaries, stressing the need why the Family Court is best suited to handle their concerns.

35. THAT what I have stated herein is true and within my own knowledge, save where otherwise specifically stated.

SWORN by the said]

KENNEDY PARSIMEI OLE MUNGUTI]

At Nairobi]

This 25th day of MAY 2013]

Before me]



Commissioner for Oaths]

[Handwritten Signature]
.....
Deponent

Drawn & filed by:

D.B. Wati & Co. Advocates
2nd Floor, Kenya House
Tom Mboya Street
P.o. Box 25201-00100
Nairobi

157



To be served upon:-

Naikuni, Ngaah & Miencha Advocates
1st Floor, Embassy House
Harambee Avenue
P.o. Box 42193-00100
Nairobi

Oraro & Co. Advocates
3rd Floor, Wing C
ACK Garden House
P.o. Box 51236-00200
Nairobi

158



REPUBLIC OF KENYA
IN THE HIGH COURT OF KENYA T NAIROBI
(FAMILY DIVISION)
SUCCESSION CAUSE NO. 2395 OF 2003

IN THE MATTER OF: THE ESTATE OF SIAMETO OLE MUNGUTI (DECEASED)

AND

IN THE MATTER OF: THE RIGHT TO FAIR HEARING, EQUALITY BEFORE THE LAW AND RIGHT TO PROPERTY,

AND

IN THE MATTER OF: THE REGISTRERED LAND ACT CAP 300 LAWS OF KENYA (NOW REPEALED).

IN THE MATTER OF: ARTICLES 19, 21, 22, 23, 27, 40, 47, 159, 165(3)(b), 258 AND 259 OF THE CONSTITUTION

BETWEEN

ATHMAN SALIM MOHAMMED on his own behalf
and on behalf of 48 Others.....INTENDED INTERESTED PARTIES/APPLICANTS

REGISTRAR OF LANDS, NGONG.....2ND INTENDED INTERESTED PARTY

THE CHIEF LANDS REGISTRAR..... 3RD INTENDED INTERESTED PARTY

THE ATTORNEY GENERAL.....4TH INTENDED INTERESTED PARTY

AND

THE ESTATE OF SIAMETO OLE MUNGUTI..... RESPONDENT

LETTER OF AUTHORITY

We, the undersigned persons, hereby authorize Mr. ATHMAN SALIM MOHAMMED, to make this application on our behalf:

This is the exhibit marked "A"
referred to in the sworn affidavit of Athman Salim Mohammed
declared before me this 8th day of June 2005
Commissioner for Oaths



RESIDENTS OF NGONG KIBIKO				
CASE NO.	7/6/2014			
NAME	Title No.	Telephone No.	Signature	
1	MARTIN N. NJIHIA	42132	0722-300 481	<i>[Signature]</i>
2	STELAH MITEMA	42141	0720558539	<i>[Signature]</i>
3	James N'IGE M		072472323	<i>[Signature]</i>
4	DAVID GITAU NJAN	48293	0721-969429	<i>[Signature]</i>
5	PATRICK KIPTOO KIPROP	40037	0739566677	<i>[Signature]</i>
6	JAMES W. MUGU	51927	0721779692	<i>[Signature]</i>
7	BONIFACE AMERA SHIKAU	47291	0720 721734	<i>[Signature]</i>
8	STEPHEN MBUWA GITAU	69235	0720495696	<i>[Signature]</i>
9	Daniel Ndungu	42694	0721268984	<i>[Signature]</i>
10	James LEGISHO N	46095	0725595539	<i>[Signature]</i>
11	JOSEPH M. KAMAU	45029	0738759840	<i>[Signature]</i>
12	WILSON K. ANGWENYI	42017	0710161528	<i>[Signature]</i>
13	ANN NYAMBURA		07271186273	<i>[Signature]</i>
14	JOHN WAWERU NYAKU	39407	0720325796	<i>[Signature]</i>
15	SAMUEL GITONGA NTERU		0722346367	<i>[Signature]</i>
16	MATURA O. NYAKUNDI	41785	0722650371	<i>[Signature]</i>
17	JACKSON MWARARA	42153	0716833196	<i>[Signature]</i>
18	BROWN K. BUDAMBULA	40023	0711470365	<i>[Signature]</i>
19	DONIC NYAMBANE		0721666826	<i>[Signature]</i>
20	Ramadhan Obure	53078	0721416673	<i>[Signature]</i>
21	SALIM O. ONGAKI	39399	0727207628	<i>[Signature]</i>
22	Evans Walea	40769 46972	072077321	<i>[Signature]</i>
23	Jedekiah Orokia		0722823815	<i>[Signature]</i>
24	Francis M. Ndungu		0721909586	<i>[Signature]</i>
25	Mary W. MUMUN	38545, 38379,38380	0722726785	<i>[Signature]</i>

121



26	Victor & Mary Mulama	54718	0720323887	MD
27	Jane Okaka Angich	43265	0721256187	FM
28	EVANGELINE WANJIRU	56311	0721541370	AK
29	FRANCIS KACIBCHE & MARY KANYAKA	56005	0717159594	JK
30	STEPHEN MBUGWA GITAU	62235	0700495696	AK
31	Richard Dikato Okero		0711605212	OM
32	Wilfred Obulu	48291	072677141	M
33	JOSHUA OMYAWCHA	46792	0727155352	+
34	PAUL Juma	51926	072378996	Okma
35	Peris Oulati	42145	0726100698	PM
36	FATIH MUMBA	39405	0721100037	BS
37	Samuel Mburu	53077	0721945228	SK
38	Daniel Otwoma mwen	42560	0719716219	FA
39	JOSPHAT LUMPO	43267	0721942561	C
40	ZACHARIAH OMBATI	53511	0721002047	AK
41	ANTHONY MACHOZA	39398	0724968590	MA
42	Margaret Wogaki Njenge	43269	0724973599	Mjenge
43	Benson Mwaniki Thuku	43039	0721344053	Thuku
44	FREDERICK RUGO	39205	0724832196	Rugo
45	John Machani	54915	0721329018	MA
46	Asunta Wanjiku	40286	0717444681	MA
47	Grace Wangui Ngatia	37849	0721236350	MA
48	ATIMAN SAMM	223748	0728093708	MA
49	WILFRED MUKWA	223747	0735422673	MA
50				
51				
52				
53				
54				

135



**REPUBLIC OF KENYA
IN THE HIGH COURT OF KENYA AT NAIROBI
SUCCESSION CAUSE NO 227 OF 1980**

**IN THE MATTER OF THE ESTATE OF SIAMETO OLE MUNGUTI
(DECEASED)**

SUMMONS

HIGH COURT OF KENYA
PROBATE & EXECUTORSHIP
24 NOV 2008
FAMILY DIVISION REGISTRY
NAIROBI

LET ALL PARTIES CONCERNED attend the judge in chambers on the day of January 2009 at 9.00 am in the forenoon or soon thereafter on the hearing of an application on the part of applicants for an order that:- 14K

1. THAT the grant of letters of administration was issued to NEPRUKO MUNGUTI SIAMETO who objected to the said grant.
2. THAT the said grant has to be substituted since the said NEPRUKO MUNGUTI SIAMETO died on the 27th August 2008.
3. THAT we are requesting this Honourable court to substitute the name of NEPRUKO MUNGUTI SIAMETO with SIMON OLE MUNGUTI.

Which application will grounded upon the affidavit of the applicant filed herewith, the nature of the case and the reasons to be offered.

DATED at NAIROBI this 28th day of October 2008

SIMON OLE MUNGUTI

Signature

**ANTHONY GUTO MOGERE
ADVOCATE**

Issued on the P. O. Box 61323 - 00200
NAIROBI

Drawn & filed by
MOHAMMED MUIGAI
ADVOCATES
K-REP CENTRE
WOOD AVENUE
NAIROBI

**P. K. NJOROGE & CO
ADVOCATES**

RECEIVED BY [Signature]

DATE 25/11/08 TIME

ACTION

133



M. MOHAMMED MUIGAI
ADVOCATES

COMMISSIONERS FOR OATHS & NOTARIES PUBLIC

MOHAMMED NYAGGA
GITHU MUIGAI
GEOFFREY IMENDE
JOAN MUTABARI
CRISPINE ODHIAMBO

PAULETTE ACHIFRIS
MUTIGI TIRAIKOLU
GUYO MUGERE

OUR REF: M157/001/L/06G
YOUR REF: T.B.A
DATE: 6th MAY 2009

Ms P.K Njoroge & Co. Advocates
Jubilee Insurance Exchange, 2nd
NAIROBI

Dear Sirs,

RE: PUBLIC AUCTION OF NGONG TOWNSHIP/32 BELONGING TO THE LATE
SIAMETO OLE MUNGUTI

We refer to the above matter.

It has been brought to our attention that the above property is due to be auctioned on 9th May, 2009 by Public Auction. Yet, as you may be aware, the captioned property is subject to ongoing suits both in the High Court and Court of Appeal.

We shall be obliged to know the reason why the aforesaid property is subject to an auction, or we shall seek the courts intervention to stop the said exercise.

Yours faithfully,
MOHAMMED MUIGAI

EMMANUEL WETANGULA
estw@mohammedmuigai.com

- Cc. Elan Traders
Information House, 2nd flr, Rm 14
Mfangano Street
Nairobi
- Cc. OCS
Ngong Ngong Police Station
Kajiado District
Kajiado
- Cc. Chief
Kibiko Location
Ngong Division
Kajiado District
Kajiado
- Cc. Client

This is the exhibit marked **SN1**
 Referred to in the Declaration/Affidavit
 of **Simon Muguta**
 Day of **May** at this
 in the Republic of Kenya at Nairobi
 Commissioner for Oaths

134



132



136

EDITION: 1		PART A - PROPERTY SECTION	
OPENED: 4.09.97		EASEMENTS ETC.	NATURE OF TITLE
REGISTRATION SECTION			ABSOLUTE
NGONG/NGONG			
PARCEL NUMBER			
20323			
APPROXIMATE AREA			
1.1 Ha.			
REGISTRY MAP SHEET No.			
8 SE & 13/NE			

SUBDIVISION OF NO.27		PART B - PROPRIETORSHIP SECTION			
ENTRY No.	DATE	NAME OF REGISTERED PROPRIETOR	ADDRESS AND DESCRIPTION OF REGISTERED PROPRIETOR	CONSIDERATION AND REMARKS	SIGNATURE OF REGISTRAR
1	4.09.97	NEPUNKO MUNGUTI SIAMITO	Box 75 NGONG HILLS.		
2	4.9.97	TITLE	DEED TO NO 1063223 by ISSUED		
3	3.3.99	CANTON BY MICHAEL SIMONKA MUNGUTI OF	NO BOX 23, NAROK CLAIMING BENEFICIARY INTEREST.		
4	27.10.99	CANTON ENTAY NO ABOVE REMOVED UNDER	SECT 1332(A)		
5	27.10.99	SIMON OLE MUNGUTI	10/10631543	GIFT. ISSUED.	
6	27.10.99	GIFT DEED			
7	20.1.2000	restriction no dealing to be registered until application at the court of appeal is determined			

Kalamazoo
business systems
21337-611
TITLE BELOW
THIS LINE

TITLE NUMBER

REGISTRATION SECTION
NGONG/NGONG

PARCEL No.
20323

136



137

CONTINUATION PAGE (2)

EDITION:		PART A - PROPERTY SECTION	
OPENED:			
REGISTRATION SECTION	EASEMENTS ETC.		NATURE OF TITLE
<i>Month/Month</i>			ABSOLUTE
PARCEL NUMBER			
<i>20323</i>			
APPROXIMATE AREA			
Ha.			
REGISTRY MAP SHEET No.			

PART B - PROPRIETORSHIP SECTION					
ENTRY No.	DATE	NAME OF REGISTERED PROPRIETOR	ADDRESS AND DESCRIPTION OF REGISTERED PROPRIETOR	CONSIDERATION AND REMARKS	SIGNATURE OF REGISTRAR
8	2.10.2007	RESTRICTION ENTRY NO. 7 REMOVED AS PER AFFIDAVIT IN FILE.			<i>[Signature]</i>
9	31.10.2001	PETER MARTIN RICHAMBA	BOX 14 MOUND HILLS	DEED	<i>[Signature]</i>
10	31.10.2001	TITLE		ISSUED	
11	30.8.02	COURT ORDER: NO DEALINGS UNTIL SUCCESSION CAUSE NO. 227 OF 1980 IS FINALIZED AT HIGH COURT OF (H) AT NBI			
11	3-2-06	COURT ORDER ENTRY NO. 11 ABOVE REMOVED UNDER CIVIL CASE NO. 123 OF 2006 DATED 24.10.06.			
12	21.5.2008	MEGARACK TRADING LIMITED		(KSHS 300,000/-)	<i>[Signature]</i>

Kalamazoo
business systems
21337-611
TITLE BELOW
THIS LINE

TITLE NUMBER	REGISTRATION SECTION	PARCEL No.
		<i>20323</i>

134

0



lydia

CERTIFICATE OF OFFICIAL SEARCH

TITLE NO. 16006/16006/23747 SEARCH No.

On the 16th day of OCTOBER, 2003 the following were the subsisting entries on the register of the above-mentioned title:

PART A—Property Section (Easements, etc.)

Nature of title ABSOLUTE

Approximate area 0.2025 HECTARES

PART B—Proprietorship Section (2220 DECIMAL (TWO 2220 TWO FIVE))

Name and address of proprietor:

4. 20⁵ 2003 ATHMAN SALIM MOHAMMED

5. 20⁵ 2003 TITLE DEED ISSUED

Inhibitions, cautions and restrictions—

6. 30⁵ 04 COURT ORDER NO. DEALIMAS UNTIL SUCCESSION CAUSE NO. 227 OF 1980 AT HIGH COURT OF NBI IS FINALIZED.

PART C—Encumbrances Section (leases, charges, etc.)

IS FINALIZED.

The following applications are pending:

The certified copies requested are attached,

The fees now payable are Sh. 1000; please detach the form below, and attach to it Post Order/Money Order/Bankers Cheque/Cash for that amount and return to me within seven days of today's date.

* A stay of registration has been noted in the register.

Date 16th (10.....2003)

[Signature]
Land Registrar

*Delete if not applicable.

To: The Land Registrar,

Search No.

..... District Land Registry,

P.O. Box

Postal Order/Money Order/Banker's Cheque/Cash for Sh. attached hereto.

Signature of Applicant or his Advocate

881

REPUBLIC OF KENYA

THE REGISTERED LAND ACT
(Cap. 300)

APPLICATION FOR OFFICIAL SEARCH

TITLE No.

To: The Land Registrar,

..... District Land Registry,

Please supply—

- *(a) particulars of the subsisting entries in the register of the above-mentioned title;
- *(b) a certified copy of each of the following—

.....
.....

I/we propose
to

and application is hereby made for a stay of registration in accordance with section 43 (1) of the Act. The written consent of the proprietor accompanies this application.

Postal Order/Money Order/Banker's Cheque/Cash for Sh. is attached hereto.

I understand that any additional fee which is payable must be paid by me forthwith on demand.

Date 20.....

.....
Signature of Applicant or his Advocate

Postal address:

.....
.....
.....

*Delete if not applicable.

†The minimum fee is KSh. 100.

*

We shall then move the Court to delete the names of the people unlawfully registered.

Yours faithfully,



P. K. NJOROGE

- CC: 1. Clients
2. The District Commissioner
Kajiado District.

Received on
25/01/04 DISTRICT COMMISSIONER
KAJIADO



ORARO & COMPANY

ADVOCATES
COMMISSIONERS FOR OATHS
NOTARIES PUBLIC
PATENT AGENTS

G. O. ORARO SC
H. C. ODERA
P. O. AGER (MRS)
W. A. AMOKO
J. M. MBALUTO
A. O. ODUOR

ACK GARDEN ANNEX
6TH FLOOR
FIRST NGONG AVENUE
P.O.BOX 51236-00200
NAIROBI

Dropping Zone No. 32 Revlon Professional Plaza

139
TEL 254-020-2710426/2711480/271582
MOBILE NOS. 0733-333447/0722-203054
FAX NO. 254-020-2727209
V.A.T. REG. NO. 0011407C
PIN NO. PO51101202S
Email: oraro@africaonline.co.ke
Website: www.oraro.co.ke

ASSOCIATES

G. O. OMONDI (MRS)
J. O. AWELE
C. N. ORARO (MISS)
J. K. KITUKU
D. O. OKOTH
E. O. ODUNDO

YOUR REFERENCE

OUR REFERENCE

GOO/7631

DATE

17th July, 2014

Ngong Police Station
Ngong
NAIROBI

Dear Sir

RE: **SUCCESSION CAUSE NO. 2395 OF 2003**
ATHMAN SALIM MOHAMMED & 48 OTHERS VS. THE ESTATE OF
SIAMETO OLE MUNGUTI & 3 OTHERS

The above matter refers.

Our attention has been drawn to a letter dated 18th June, 2014 addressed to inter-alia the Kajiado County Governor-the Hon. Nkedianye and your office by Mrs. Resiatio ene Munguti and Noongipa Ole Munguti (copy enclosed).

On our clients' instructions, we have carefully reviewed the said letter and for the record wish to advise that there are currently pending legal proceedings in HCCC No. 2395 of 2003 on a raft issues among them the ownership of the parcels of land under reference in the aforesaid letter. On 10th June 2014, the Hon. Justice Musyoka issued injunctive orders in the said proceedings inter-alia restraining any person from dealing with or in any way interfering with inter-alia the aforesaid properties until further orders of the court. The said orders were on 12th June 2014 served on inter-alia Resiatio and Noongipa ene Munguti through their Advocates on record in the matter and further served on the OCS Ngong Police Station among others. The said orders remain in force and have neither been varied nor set aside. Resiatio and Noongipa ene Munguti and/or their legal advisors are very well aware of the same. Moreover, our clients in the matter are registered proprietors of several subdivisions of land emanating from the original title NGONG/NGONG.27 including those mentioned in the letter of 18th June having acquired the same for valuable consideration and without notice of any encumbrances.

ORARO & COMPANY

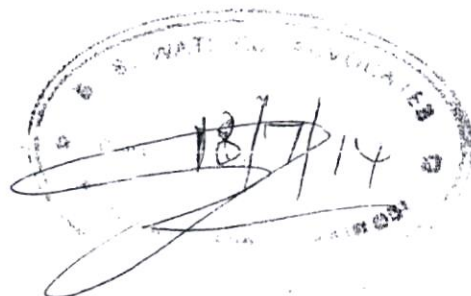

134

That Mrs. Resiato and Noongipa Munguti have written the above letter while well aware of the pending court proceedings is without a doubt a deliberate attempt to abuse your office and obviously attempt to unlawfully intimidate our clients into giving up their perfectly legitimate claims in the pending court proceedings.

Be it as it may that the families of Mrs. Resiato and Noongipa ene Munguti are experiencing serious financial problems as stated in their letter, we do not at all believe the same constitutes lawful justification to override an ongoing judicial process. We therefore take exception to the purported requests made to your office in the above letter and especially take great exception to the derogatory and misleading description of our clients as 'strangers who have invaded land without permission and erected illegal structures'.

As these issues are pending resolution in court, we wouldn't wish to dwell on them any further save to reiterate that those allegations are untrue and without any legal basis. We accordingly urge you to uphold the rule of law and treat the letter of 18th June, 2014 with the contempt it deserves.

We thank you in advance for your co-operation. Should you require further clarification or information, please do not hesitate to contact us.

Yours faithfully



D.B. WATI & COMPANY ADVOCATES

Enc.

cc:

Client

1. The County Commissioner
Kajiado County
KAJIADO
2. Hon. Nkedianye
Kajiado County Governor
KAJIADO
3. D.B Wati & Company Advocates
2nd Floor, Kenda House
Tom Mboya Street
P.O. Box 25201-00100
NAIROBI

140



EASEMENTS ETC.		NATURE OF TITLE			
PART A - PROPERTY SECTION		ABSOLUTE			
REGISTRATION SECTION		REGISTRATION SECTION			
NGONG/NGONG		NGONG/NGONG			
PARCEL NUMBER		35977			
APPROXIMATE AREA		1.2 Ha.			
REGISTRY MAP SHEET NO.		8/SE & 13/NE			
PART B - PROPRIETORSHIP SECTION					
Subdivision of no. 20322					
ENTRY NO.	DATE	NAME OF REGISTERED PROPRIETOR	ADDRESS AND DESCRIPTION OF REGISTERED PROPRIETOR	CONSIDERATION AND REVENUE	REGISTRATION SECTION
1	15.2.06	ELIZABETH STALO MONGUPTI			
2	5.4.06	DEGA			
3	25.4.06	ANDREW GIETHMBA MUGAI	10/9575520		
4	25.4.06	DEGA	10/9575520		
5	28.2.07	EZEKIEL NDIEHU KIMTHU	10/1821080		
6	28.2.07	LEAH NIAMBI	10/5912834		
7	28.2.07	DEGA	10/5912834		
REGISTRATION SECTION NGONG/NGONG					
TITLE NUMBER 35977					

C.F.C.

[Signature]

[Handwritten signature]

propose
the
thwith
cate

141

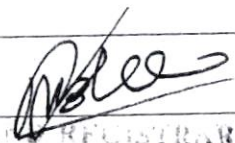

142

EDITION: 1		PART A - PROPERTY SECTION	
OPENED: 9.6.08			
REGISTRATION SECTION	EASEMENTS ETC.		NATURE OF TITLE
MOONE / NGONG	 DISTRICT REGISTRAR BAMBANG		ABSOLUTE
PARCEL NUMBER			
APPROXIMATE AREA			
REGISTRY MAP SHEET NO.			
	42143		
	0.05 Ha.		

PART B - PROPRIETORSHIP SECTION					
ENTRY NO.	DATE	NAME OF REGISTERED PROPRIETOR	ADDRESS AND DESCRIPTION OF REGISTERED PROPRIETOR	CONSIDERATION AND REMARKS	SIGNATURE OF REGISTRAR
1	9.6.08	MEGA RACK TRADING LIMITED			
2	9.6.08	TITLE DEED		ISSUED	
3	17.10.08	LUCAS ODEARA HAJULA	10/0803021		
4	17.10.08	TITLE DEED	Box 24067 - 00100 NBI	ISSUED	

Entrance
Signature

143

EDITION: 1
OPENED: 3.2.06
PART A - PROPERTY SECTION

REGISTRATION SECTION
MONG/NGONG
FASWEN TS ETC.

PARCEL NUMBER
51101

APPROXIMATE AREA
0.13 Ha.

REGISTRY MAP SHEET NO.
9 SP. & 13 NG

SUBDIVISION OF NO. 23746
PART B - PROPRIETORSHIP SECTION

NAME OF REGISTERED PROPRIETOR
NEPUTIKO MUNG JPI SAMPPO 1D/1068223 BOX 75, NGONG

DATE
3.2.06

ADDRESS AND DESCRIPTION OF REGISTERED PROPRIETOR
KENNEDY CRD EA DUNDIEKI 1D/507218
3.2.06 TITLE DEED BOX 21158 NGONG

CONSIDERATION AND REMARKS
2.95

SIGNATURE
SIGNED

143

1911

