

Approved for tabling.

But
SNA
17/4/18

Paper laid by
Hon Mwangi
Gatunga, Member
Committee on
delegated
legislation

Tuesday
17/4/18
Agh.



APR 2018
PARLIAMENT
OF KENYA
LIBRARY

PARLIAMENT
OF KENYA
LIBRARY

THE NATIONAL ASSEMBLY

TWELFTH PARLIAMENT-SECOND SESSION

COMMITTEE ON DELEGATED LEGISLATION

REPORT ON THE NATIONAL TRANSPORT SAFETY AUTHORITY (OPERATION OF COMMERCIAL VEHICLES) REGULATIONS, 2018

APRIL 2018

Directorate of Committee Services
The National Assembly,
Parliament Buildings, Continental House, Room 402
NAIROBI

TABLE OF CONTENTS

ABBREVIATIONS	3
CHAIRPERSON'S FOREWORD	4
EXECUTIVE SUMMARY	5
1.0 PREFACE.....	6
1.1 Mandate of the Committee.....	6
1.2 Committee Membership.	7
1.3 Committee Secretariat ...	7
2.0 CONSIDERATION OF THE INSTRUMENT	8
2.1 Introduction and Background Information	8
2.2 Making of the Regulations and Committal to the Committee	8
2.3 Consideration of the Instrument.....	8
3.0 RECOMMENDATION.....	9
ANNEXURES	10

ABBREVIATIONS

EM	Explanatory Memorandum
NTSA	National Transport and Safety Authority
SI	Statutory Instruments
SO	Standing Order

CHAIRPERSON'S FOREWORD

In exercise of the powers conferred by **section 54 of the National Transport and Safety Authority Act, 2012**, the Cabinet Secretary for Transport, Infrastructure, Housing and Urban Development, in consultation with the Board of the National Transport and Safety Authority (NTSA) published the National Transport Safety Authority (Operation of Commercial Vehicles) Regulations, 2018 on 26th January, 2018 vide LN No.3/2018.

Following publication, the Regulations were tabled in the House on 20th March, 2018 and immediately committed to the Select Committee on Delegated Legislation for review and scrutiny in line with section 12 of the Statutory Instruments Act, 2013 and Standing Order 210 of the National Assembly Standing Orders.

The Committee considered the Regulations in its sitting held on Friday, 13th April 2018 and made the decision to annul the Regulations for reasons advanced herein.

The Committee wishes to express its gratitude to the Speaker for the support accorded to the Committee in the discharge of its mandate. The Committee also wishes to record its appreciation to the Office of the Clerk of the National Assembly and the supporting Directorates for providing technical support which was vital in the consideration of this instrument.

On behalf of the Members of the Select Committee on Delegated Legislation and pursuant to Standing Order 210 (4), it is my pleasure and duty to present to the House the Committee's Report on the National Transport Safety Authority (Operation of Commercial Vehicles) Regulations, 2018.

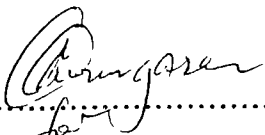
Signed.......... Date.....17/4/2018.....
HON. GLADYS BOSS SHOLLEI, CBS, MP
CHAIRPERSON, COMMITTEE ON DELEGATED LEGISLATION

EXECUTIVE SUMMARY

The National Transport Safety Authority (Operation of Commercial Vehicles) Regulations, 2018 were tabled in the House on 20th March, 2018 and immediately committed to the Select Committee on Delegated Legislation for review and scrutiny in line with section 12 of the Statutory Instruments Act, 2013 and Standing Order 210 of the National Assembly Standing Orders.

Having considered the Regulations, the Committee observed that they were published on 26th January, 2018 and tabled in the National Assembly on 20th March, 2018. This was within the statutory timeline contemplated under section 11(1) of the Statutory Instruments Act. The Regulations also complied with all the relevant considerations contained in section 13 of the Statutory Instruments Act.

Annexed to the Regulations was an Explanatory Memorandum prepared by the National Transport and Safety Authority. The Committee, however, observed that the Memorandum did not demonstrate the extent to which consultations were undertaken. There was no evidence to ascertain who the participants were and whether public participation was indeed undertaken.

With regard to the public notice in the newspapers inviting members of the public for their comments, Members were concerned about the level of public engagement particularly those who may not have access to print media.

In view of the foregoing, the Committee recommends **that pursuant to Standing Order 210 (4) (b) and section 15 (1) of the SI Act, the National Transport & Safety Authority (Operation of Commercial Vehicles) Regulations, 2018 be annulled *in toto* for lack of clarity on the extent of public participation undertaken, contrary to Art 10 and 118 of the Constitution of Kenya.**

1.0 PREFACE

The Select Committee on Delegated Legislation is established pursuant to *Standing Order No. 210* and is mandated to consider statutory instruments submitted to Parliament for consideration. The Committee is expected to consider in respect of any statutory instrument, whether it is in accordance with the provisions of the Constitution, the Act pursuant to which it is made or other relevant written laws.

1.1 Mandate of the Committee

The Committee is mandated to consider in respect of any statutory instrument, whether it: -

- (i) is in accordance with the provision of the Constitution, the Act pursuant to which it is made or other relevant written laws;
- (ii) infringes on fundamental rights and freedoms of the public;
- (iii) contains a matter which in the option of the Committee should more properly be dealt with in an Act of the Parliament;
- (iv) contains imposition of taxation;
- (v) directly or indirectly bars the jurisdiction of the court;
- (vi) gives retrospective effect to any of the provision in respect to which the Constitution does not expressly give any such power;

The Committee is equally tasked with the responsibility of scrutinizing statutory instruments, whether: -

- (i) it involves expenditure from the consolidated fund or other public revenues;
- (ii) is defective in its drafting or for any reason form or part of the statutory instrument calls for any elucidation;
- (iii) appears to make some unusual or unexpected use of the power conferred by the Constitution or the Act pursuant to which it is made;
- (iv) appears to have had unjustifiable delay in its publication or laying before Parliament;
- (v) makes rights, liberties or obligations unduly dependent upon non-renewable decisions;
- (vi) makes rights, liberties or obligations unduly dependent insufficiently defined administrative powers;
- (vii) inappropriately delegates legislative powers;
- (viii) imposes a fine, imprisonment or other penalty without express authority having been provided for in the enabling legislation;

- (ix) appears for any reason to infringe on the rule of law;
- (x) inadequately subjects the exercise of legislative power to Parliamentary scrutiny; and
- (xi) accords to any other reason that the Committee considers fit to examine.

1.2 Committee Membership

The Committee on Delegated Legislation as constituted by the House in December 2017 comprises of the following Members –

- Hon. Gladys Boss Shollei, CBS, MP - Chairperson**
- Hon. Fatuma Gedi, MP - Vice- Chairperson**
- Hon. Alice Wahome, MP
- Hon. Robert Mbui, MP
- Hon. Daniel Maanzo, MP
- Hon. Muriuki Njagagua, MP
- Hon. Isaac Waihenya Ndirangu, MP
- Hon. Alfred Bernard Wekesa Sambu, MP
- Hon. William Kamket Kassait, MP
- Hon. Ronald Kiprotich Tonui, MP
- Hon. Munene Wambugu, MP
- Hon. Charles Gimose, MP
- Hon. Abdi Koropu Tepo, MP
- Hon. George Gitonga Murugara, MP
- Hon. Jennifer Shamalla, MP
- Hon. Muturi Kigano, MP
- Hon. Martha Wangari, MP
- Hon. Patrick Kariuki Mariru, MP
- Hon. Timothy Wanyonyi, MP
- Hon. William Kamoti, MP
- Hon. Wilberforce Oundo, MP
- Hon. Sammy Seroney, MP

1.3 Committee Secretariat

The secretariat comprises of the following members of staff –

- 1) Mr. Susan Maritim **Clerk Assistant I (Team Leader)**
- 2) Mr. Jimale Mohamed **Clerk Assistant III**
- 3) Mr. Dima Dima **Senior Legal Counsel**
- 4) Ms. Mugure Gituto **Legal Counsel II**
- 5) Ms. Anne N. Kigoro **Research & Policy Analyst**

2.0 CONSIDERATION OF THE INSTRUMENT

2.1 Introduction and Background Information

The National Transport Safety Authority (Operation of Commercial Vehicles) Regulations, 2018 were published pursuant to section 54 of the National Transport and Safety Authority Act, 2012. The Regulations apply to any commercial vehicle whose tare weight is more than three thousand and forty-eight kilograms (3048 Kgs) and operating on a public road in Kenya. The Regulations also provide that a carrier or a driver shall not operate a commercial vehicle without a valid commercial vehicle licence issued by the Authority in accordance with the provisions of regulation 6. Similarly, that all commercial vehicles shall be fitted with a speed governor that conforms to the Kenyan Standard KS 2295 or as approved by the Authority and that a commercial vehicle licence shall be valid for a period of one year and may be renewed annually.

2.2 Making of the Regulations and Committal to the Committee

In exercise of the powers conferred by **section 54 of the National Transport and Safety Authority Act, 2012**, the Cabinet Secretary for Transport, Infrastructure, Housing and Urban Development, in consultation with the Board of the National Transport and Safety Authority (NTSA) published the National Transport Safety Authority (Operation of Commercial Vehicles) Regulations, 2018 on 26th January, 2018 vide LN No.3/2018

Following publication, the Regulations were tabled in the House on 20th March, 2018 and immediately committed to the Select Committee on Delegated Legislation for review and scrutiny in line with section 12 of the Statutory Instruments Act, 2013 and Standing Order 210 of the National Assembly Standing Orders.

2.3 Consideration of the Instrument

The Committee considered the Regulations against Article 94(6) of the Constitution, National Transport & Safety Authority Act, 2012, the Statutory Instruments Act of 2013 and the Interpretation and General Provisions Act (Chapter 2), which regulate the making, scrutiny and publication of the Regulations.

The Committee considered the Regulations in its sitting held on Friday, 13th April 2018 and made the decision to annul the Regulations for reasons advanced below:

8| Committee on Delegated Legislation: Report on the National Transport Safety Authority (Operation Of Commercial Vehicles) Regulations, 2018

Committee Observations

The Committee considered the National Transport & Safety Authority (Operation of Commercial Vehicles) Regulations, 2018, and made the following observations – THAT

- (i) the National Transport & Safety Authority (Operation of Commercial Vehicles) Regulations, 2018, were published on 26th January, 2018 and laid before the National Assembly on 20th March, 2018;
- (ii) the Regulations comply with all the relevant considerations contained in section 13 of the Statutory Instruments Act;
- (iii) annexed to the Regulations was an Explanatory Memorandum prepared by the National Transport and Safety Authority. Members, however, observed that the Memorandum did not demonstrate the extent to which consultations were undertaken, who the participants were and when public participation was undertaken as required under section 11(2) of the Statutory Instruments Act, 2013 to guide the Committee on the extent and scope of stakeholders' forum; and
- (iv) with regard to the public notice in the newspapers inviting members of the public for their comments, Members were concerned about the level of public engagement particularly those who may not have access to the print media.

3.0 RECOMMENDATION

Having considered the National Transport & Safety Authority (Operation of Commercial Vehicles) Regulations, 2018 against Article 94(6) of the Constitution, National Transport & Safety Authority Act, 2012, the Statutory Instruments Act of 2013 and the Interpretation and General Provisions Act (Chapter 2), which regulate the making, scrutiny and publication of the Regulations, **the Committee recommends that pursuant to Standing Order 210 (4) (b) and section 15 (1) of the SI Act, the National Transport & Safety Authority (operation of commercial vehicles) Regulations, 2018 be annulled *in toto* for lack of clarity on the extent of public participation undertaken, contrary to Art 10 and 118 of the Constitution of Kenya on public participation, read together with sections 5 and 11 (2) of the Statutory Instruments, Act.**

9| Committee on Delegated Legislation: Report on the National Transport Safety Authority (Operation Of Commercial Vehicles) Regulations, 2018

ANNEXURES

- (i) Minutes of Committee
- (ii) Sitings
- (iii) Adoption List
- (iv) Copy of the National Transport & Safety Authority (Operation of Commercial Vehicles) Regulations, 2018

MINUTES OF THE 24TH SITTING OF THE COMMITTEE ON DELEGATED LEGISLATION HELD ON THURSDAY, 13TH, APRIL 2018, AT 2.00 P.M. AT SERENA BEACH RESORT MOMBASA

PRESENT

Hon. George Gitonga Murugara, MP (Chairing)
Hon. Timothy Wanyonyi, MP
Hon. Alice Wahome, MP
Hon. Muriuki Njagagua, MP
Hon. Charles Gimose, MP
Hon. Dan Maanzo, MP
Hon. Martha Wangari, MP
Hon. Muturi Kigano, MP
Hon. Patrick Kariuki Mariru, M.P.
Hon. Jennifer Shamalla, MP
Hon. William Kamoti, MP
Hon. Munene Wambugu, MP
Hon. Sammy Seroney, MP

ABSENT WITH APOLOGY

Hon. Gladys Boss Shollei, CBS, MP - Chairperson
Hon. Fatuma Gedi, MP - Vice Chairperson
Hon. Robert Mbui, MP
Hon. William Kamket Kassait, MP
Hon. Alfred Sambu, MP
Hon. (Dr.) Wilberforce Oundo, MP
Hon. Ronald Kiprotich Tonui, MP
Hon. Isaac Waihenya Ndirangu, MP
Hon. Abdi Koropu Tepo, MP

IN-ATTENDANCE

National Assembly Secretariat

Ms. Susan Maritim - First Clerk Assistant
Mr. Jimale Mohamed - Third Clerk Assistant
Mr. Dima Dima - Senior Legal Counsel
Ms. Mugure Gituto - Legal Counsel II
Ms. Anne Kigoro - Research & Policy Analyst
Mr. Charles Ayari - Audio Officer
Mr. Anthony Wamae - Serjeant-At-Arms
Ms. Rehema Manzura - Secretary

MIN.NO. CDL/161/2018: PRELIMINARIES

Hon. George G. Murugara, MP called the meeting to order at 10.30 am and welcomed Members of the Committee to consider the National Transport Safety Authority (Operation of Commercial Vehicles), Regulations 2018.

MIN.NO. CDL/162/2018: CONSIDERATION OF THE NATIONAL TRANSPORT SAFETY AUTHORITY (OPERATION OF COMMERCIAL VEHICLES) REGULATIONS, 2018

The Committee considered the National Transport & Safety Authority (Operation of Commercial Vehicles) Regulations, 2018, and made the following observations;

- (i) the Regulations were published on 26th January, 2018 and laid before the National Assembly on 20th March, 2018.
- (ii) annexed to the Rules was an Explanatory Memorandum prepared by the National Transport and Safety Authority. Members, however, observed that the Memorandum did not demonstrate the extent to which consultations were undertaken, who the participants were and when public participation was undertaken as required under section 11(2) of the Statutory Instruments Act, 2013 to justify and guide the Committee on the extent and scope of stakeholders' forum.

Resolution

Having considered the National Transport & Safety Authority (Operation of Commercial Vehicles) Regulations, 2018 against Article 94(6) of the Constitution, National Transport & Safety Authority Act, 2012, the Statutory Instruments Act of 2013 and the Interpretation and General Provisions Act (Chapter 2), which regulate the making, scrutiny and publication of the Regulations, **the Committee recommends that pursuant Standing Order 210 (4) (b) and section 15 (1) of the SI Act, the National Transport & Safety Authority (Operation of Commercial Vehicles) Regulations, 2018 be annulled *in toto* for lack of clarity on the extent of public participation undertaken.**

This decision was proposed by Hon. Munene Wambugu, MP and seconded by Hon. Daniel Maanzo, MP.

MIN.NO. CDL /163/2018: ANY OTHER BUSINESS

The Committee also resolved as follows in future consideration of instruments –

- i. to always confer with the regulation-making authority;
- ii. to invite submissions from affected stakeholders; and
- iii. to undertake field study where necessary.

The Committee was also informed that the Senate (Monitoring and Evaluation) Regulations, 2018 are before the Committee and are scheduled for consideration on Saturday, 21 April, 2018 in Mombasa.

On foreign visits, the Committee was informed that the secretariat is working on two upcoming activities to be held in the United States of America in May, 2018. Details will be availed to the Members in subsequent meetings.

MIN.NO. CDL /164/2018: ADJOURNMENT

There being no other business, the meeting was adjourned at 3.30 p.m. until Tuesday, 17 April, 2018 at 11.30 a.m.

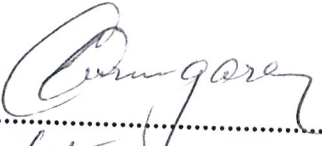
Signed: 

Date: 17/4/2018

**HON. GLADYS BOSS-SHOLLEI, CBS, MP
(CHAIRPERSON)**



COMMITTEE ON DELEGATED LEGISLATION



ADOPTION LIST

REPORT ON THE ADOPTION OF THE NATIONAL TRANSPORT AND SAFETY AUTHORITY (OPERATION OF COMMERCIAL VEHICLES) REGULATIONS, 2018

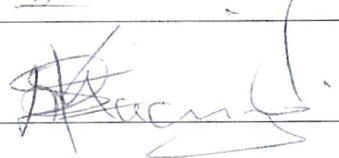
We, the undersigned, hereby affix our signatures to this Report to affirm our approval:

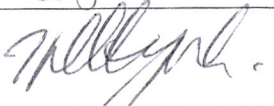
DATE: 17/04/2018

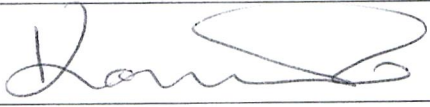
	HON. MEMBER	SIGNATURE
1.	Hon. Gladys Boss-Shollei, MP (Chairperson)	
2.	Hon. Fatuma Ali Gedi, MP (Vice Chairperson)	
3.	Hon. Alfred Sambu, MP	
4.	Hon. Isaac Waihenya Ndirangu, MP	
5.	Hon. Robert Mbui, MP	
6.	Hon. Alice Wahome, MP	
7.	Hon. Daniel Maanzo, MP	
8.	Hon. Muriuki Njagagua, MP	
9.	Hon. Martha Wangari, MP	
10.	Hon. Timothy Wanyonyi, MP	

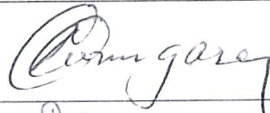
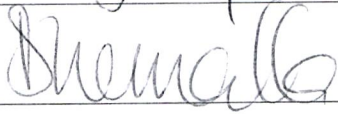
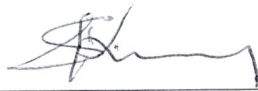
	HON. MEMBER	SIGNATURE
11.	Hon. William Kamoti, MP	
12.	Hon. Patrick Kariuki Mariru, MP	
13.	Hon. Ronald Kiprotich Tonui, MP	
14.	Hon. William Kamket Kassait, MP	
15.	Hon. Munene Wambugu, MP	
16.	Hon. Charles Gimose, MP	
17.	Hon. Abdi Tepo, MP	
18.	Hon. George Gitonga Murugara, MP	
19.	Hon. Jennifer Shamalla, MP	
20.	Hon. Muturi Kigano, MP	
21.	Hon. (Dr.) Wilberforce Oundo, MP	
22.	Hon. Sammy Seroney, MP	

LEGAL NOTICE No. 3

THE NATIONAL TRANSPORT AND SAFETY AUTHORITY ACT

(No. 33 of 2012)

THE NATIONAL TRANSPORT AND SAFETY AUTHORITY
(OPERATION OF COMMERCIAL VEHICLES) REGULATIONS,
2018

Arrangement of regulations.

- 1—Citation.
- 2—Interpretation.
- 3—Application of these Regulations.
- 4—Safety responsibility.
- 5—Commercial vehicle to be licensed.
- 6—Application for a commercial vehicle licence.
- 7—Securing of cargo generally.
- 8—Securing of certain cargo.
- 9—Retro-reflective contour markings for commercial vehicles and trailers.
- 10—Parking.
- 11—Daily driving and on-duty time.
- 12—Mandatory rest time.
- 13—Daily log sheet.
- 14—Safety audits.
- 15—Record and reporting requirements.
- 16—Removal or towing of vehicles.
- 17—Revocation or suspension of commercial vehicle licence.
- 18—Power of the Authority to order inspection.
- 19—Insurance.
- 20—Appeals.
- 21—Offences and penalties.

THE NATIONAL TRANSPORT AND SAFETY AUTHORITY ACT

(No. 33 of 2012)

IN EXERCISE of the powers conferred by section 54 of the National Transport and Safety Authority Act, 2012, the Cabinet Secretary for Transport, Infrastructure, Housing and Urban Development, in consultation with the Board, makes the following regulations—

THE NATIONAL TRANSPORT AND SAFETY AUTHORITY
(OPERATION OF COMMERCIAL VEHICLES) REGULATIONS,
2017

1. These regulations may be cited as the National Transport and Safety Authority (Operation of Commercial Vehicles) Regulations, 2017. Citation.
2. In these regulations, unless the context otherwise requires— Interpretation.
 - “Appeals Board” means the Transport Licensing Appeals Board established under section 39 of the Act;
 - “authorised officer” means
 - “Authority” means the National Transport and Safety Authority established under section 3 of the Act;
 - “Cabinet Secretary” has the meaning assigned to it under the Act;
 - “carrier” means a corporate body or an individual with operational responsibility over a commercial vehicle on a day to day basis either as the registered owner of the vehicle or pursuant to a contract or franchise agreement with the registered owner of the vehicle but does not include the driver of the vehicle;
 - “commercial vehicle licence” means a licence issued by the Authority under the Act, for the operation of a commercial vehicle;
 - “commercial vehicle” has the meaning assigned to it under the Traffic Act; Cap 403.
 - “corporate body” means a limited liability company registered under the Companies Act, and includes a cooperative society registered under the Cooperative Societies Act and a society registered under the Societies Act; No. 17 of 2015.
Cap 490.
Cap 108.
 - “heavy commercial vehicle” has the meaning assigned to it under the Traffic Act; Cap 403.
 - “off-duty time” means any period other than on-duty time;
 - “on-duty time” means driving time;
 - “owner” means the registered owner of a commercial vehicle;
 - “public road” has the meaning assigned to it under the Public Roads and Roads of Access Act;
 - “retro-reflective marking material” means a surface or a device from which, when directionally illuminated, a relatively large portion of the incident radiation is retro-reflected; Cap 399.

“Third Party Motor Vehicle Insurance” means an insurance policy by that name issued in respect to a public service vehicle pursuant to the provisions of the Insurance (Motor Vehicle Third Party Risks) Act; and

Cap 405.

“urban area” has the meaning assigned to it under the Urban Areas and Cities Act.

No. 13 of 2011.

3. These regulations shall apply to any commercial vehicle—

Application of these Regulations.

(a) whose tare weight is more than three thousand and forty eight kilograms; and

(b) operating on a public road in Kenya.

4. A carrier shall not operate a commercial vehicle if—

Safety responsibility.

(a) the vehicle does not comply with these regulations;

(b) the driver of the commercial vehicle fails or refuses to take any action required to be taken under these regulations;

(c) the cargo transported by the commercial vehicle is not contained, covered, immobilized or secured in accordance with these regulations; or

(d) the driver of the commercial vehicle is not licensed to drive a commercial vehicle.

5. (1) A carrier or a driver shall not operate a commercial vehicle without a valid commercial vehicle licence issued by the Authority in accordance with the provisions of regulation 6.

Commercial vehicle to be licensed.

(2) All commercial vehicles shall be fitted with a speed governor that conforms to the Kenyan Standard KS 2295 or as approved by the Authority.

(3) A commercial vehicle licence shall be valid for a period of one year and may be renewed annually.

6. (1) A carrier or a driver may apply for a commercial vehicle licence by submitting an application in the form set out in the First Schedule and the application shall be accompanied by—

Application for a commercial vehicle licence.

(a) the prescribed fee as set out in the Second Schedule;

(b) a certificate of incorporation if the applicant is a company incorporated under the Companies Act, 2015;

(c) a certificate of registration if the applicant is a co-operative society registered under the Co-operative Societies Act;

(d) a certificate of registration if the applicant is a society registered under the Societies Act;

No. 17 of 2015.

(e) a national identity card if the applicant is an individual;

(f) the certificate of ownership or other evidence of ownership of the vehicle in the name of the applicant or a contract or franchise agreement between the owner and the carrier or intended carrier of the vehicle;

Cap 490.

19. A carrier shall take out, at the minimum, third party Insurance. insurance cover for each of its commercial vehicles.

20. A person aggrieved by any decision made by the Authority Appeals. under these regulations may, within fourteen days of being notified of the decision, appeal to the Appeals Board against the decision.

21. Any person who contravenes any provision of these Offences and penalties. regulations commits an offence and shall be liable on conviction to a fine not exceeding twenty thousand shillings or to imprisonment for a term not exceeding six months or to both.

FIRST SCHEDULE

(r. 6(1))



APPLICATION FOR COMMERCIAL SERVICE LICENCE

FOR OFFICIAL USE

Application Number

A. APPLICANT'S INFORMATION

Name of Registered Owner: _____ Address: _____

E-mail address _____ Mobile No. _____

B. TYPE OF VEHICLE.

Tick the type of vehicle.

 Commercial Vehicle Heavy Commercial Vehicle

C. DOCUMENTATION REQUIRED. (Applicant MUST provide copies of the listed documents).

DOCUMENT REQUIRED	TICK IF PROVIDED	FOR OFFICIAL USE
Certificate of incorporation as a company under the Companies Act if the applicant is a company or certificate of registration if the applicant is a cooperative society under the Cooperative Societies Act or if the applicant is a society or national identification card if the applicant is an individual.		

DOCUMENT REQUIRED	TICK IF PROVIDED	FOR OFFICIAL USE
The certificate of ownership or other evidence of ownership in the name of the owner of the vehicle or a contract or franchise agreement between the owner and the carrier or intended carrier of the vehicle.		
A valid certificate of roadworthiness issued by the Authority of each vehicle in respect to which an application is being made.		
Valid insurance cover.		
Evidence showing that all the commercial vehicles have been fitted with the prescribed speed governor.		
Evidence of installation of a fleet management system accredited by the Authority (for heavy commercial vehicles only).		

D. DECLARATION.

I declare that I have read all the answers I have given to the questions in this application and that the answers given by me are complete, true and correct in every detail.

I understand that if I have stated anything that is false or misleading, the licence granted to me as a result of this application may be absolutely void and have no legal effect whatsoever.

I understand that I may be prosecuted for giving or stating facts or misleading information or documents.

I also declare that I have read and understood the general duties and responsibilities of a transport operator and hereby agree to be bound by them.

Applicants' signature

Date _____

SECOND SCHEDULE

(r. 6 (1) (a))

FEES

Application fee for a commercial licence (per vehicle).....	Kshs 2,000.
Renewal of licences.....	Kshs 1,500.
Replacement of damaged or lost licence.....	Kshs 1,500.

THIRD SCHEDULE

(r. 9 (1))

RETRO-REFLECTIVE MARKING FOR COMMERCIAL VEHICLES AND THEIR TRAILERS

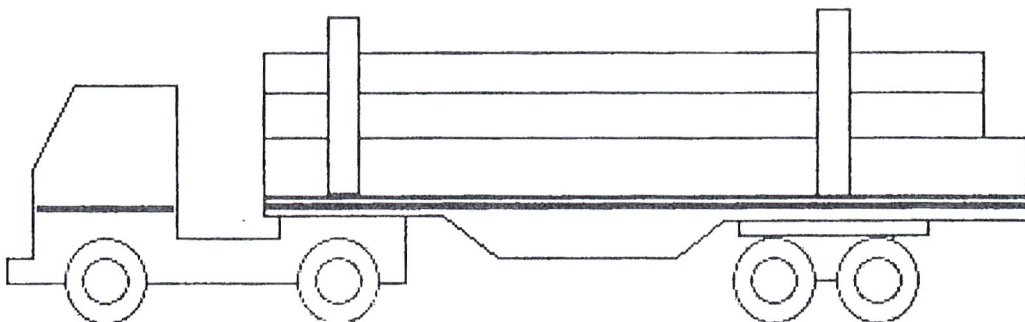
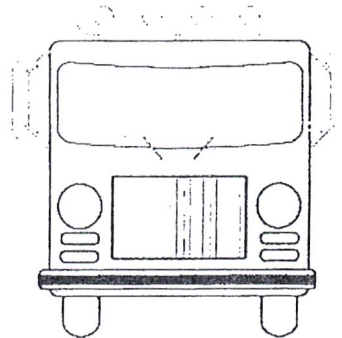
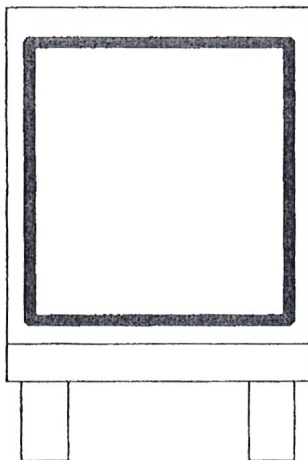
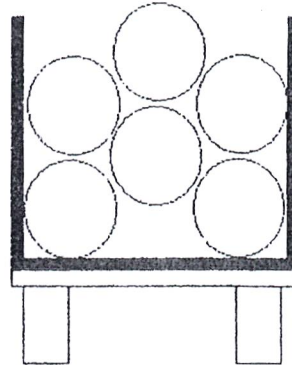
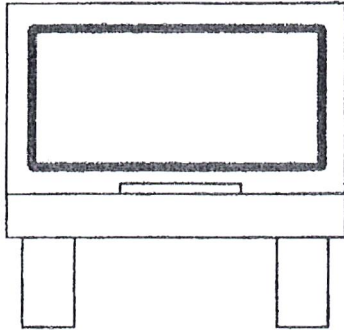

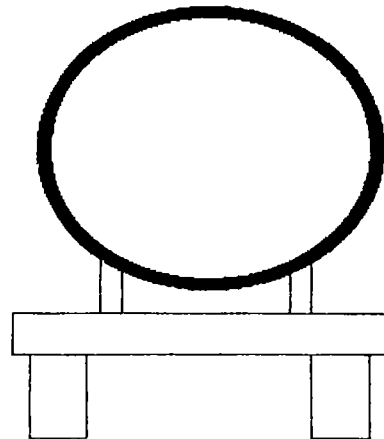
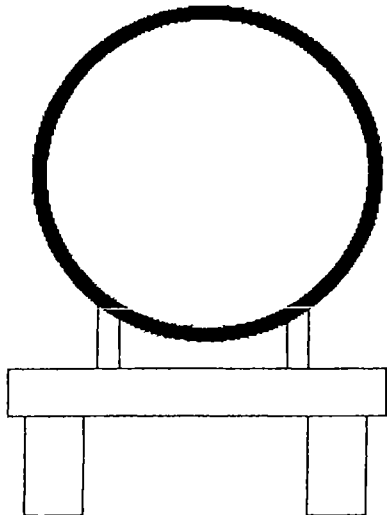
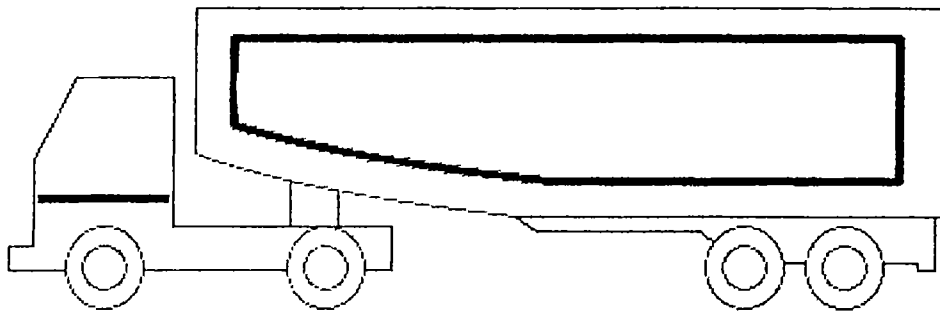
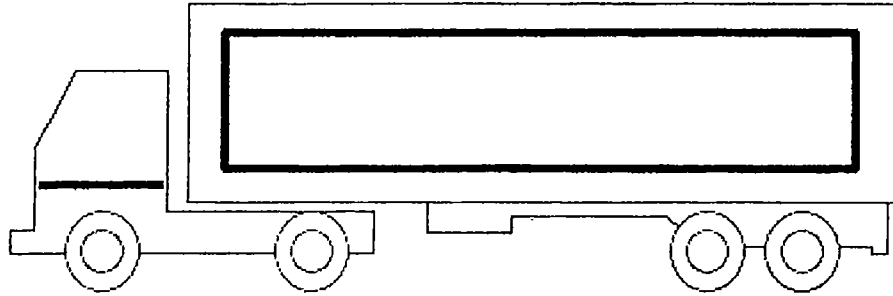

FOURTH SCHEDULE

(r. 13(1))

DAILY LOG

DATE	START OF DRIVING TIME	END OF DRIVING TIME	REST PERIODS TAKEN (TIME)	LOCATION OF VEHICLE AT START OF JOURNEY AND MILEAGE READING	LOCATION OF VEHICLE AT END OF JOURNEY AND MILEAGE READING

Driver's name

Signature.....

Vehicle Registration No

FIFTH SCHEDULE

(r. 15(3))

ACCIDENT REPORT FORM

Name of Registered Owner of Commercial Vehicle:- _____

Date and location of accident: _____

Registration number of vehicles involved in accident:- _____

Licence Number of commercial vehicle:- _____

Driver's Name: - _____

Driving licence No. of driver of Commercial Vehicle:- _____

Number of confirmed fatalities: _____

Circumstances about the accident/ probable cause:- _____

Dated the 11th January, 2018.

JAMES MACHARIA,
Cabinet Secretary for Transport,
Infrastructure, Housing and Urban Development.

LEGAL NOTICE NO. 4

THE FERRIES ACT

(Cap. 410)

IN EXERCISE of the powers conferred by section 6 of the
Ferries Act, the Cabinet Secretary makes the following Rules—

THE FERRIES (VEHICLE TOLL CHARGES) (AMENDMENT)
RULES, 2018

1. These Rules may be cited as the Ferries (Vehicle Toll
Charges) (Amendment) Rules, 2018. Citation.

2. The Ferries (Vehicle Toll Charges) Rules, 2002 are amended
by deleting the Schedule and substituting therefor the following new
Schedule— Amendment of
L.N. 88 of 2002.

SCHEDULE

Category	Vehicle length (Metres)	Rates (Shs.)
Car	3.5	120
Car	4.5	120
Car	6	150
Land Rover	6	250
Pickup		150
Car (Towing)	3.5 – 6	300
Kombi	5	280